

Scambiatori a Piastre Saldobrasate

Brazed Plate Heat Exchangers



EMMEGI



APPLICAZIONI:

APPLICATIONS :

- Recuperi Termici da Processi Industriali / Industrial Process Heat Recovery
- Refrigeratori Olio / Oil Coolers
- Impianti Fotovoltaici / Photovoltaic Installations



EMMEGI

HEAT-EXCHANGERS
www.emmegi-heat-exchangers.com



Scambiatori a Piastre Saldobrasate

Brazed Plate Heat Exchangers

Vantaggi degli scambiatori a piastre saldobrasate

- Alto coefficiente di scambio termico ;
- Dimensioni contenute con alte performance ;
- Alta resistenza alla pressione e temperatura ;
- Connessioni in AISI 321 ;
- Facile installazione ;

Gli scambiatori a piastre sono costituiti da piastre corrugate.

Le piastre sono ruotate di 180° l'una dall'altra al fine di creare un reticolo di canali intersecati. I fluidi possono fluire sia in controcorrente che equicorrente.

Le piastre sono unite insieme tra loro con materiale brasante in speciali forni sottovuoto.

La speciale corrugazione permette al fluido di turbolare aumentando lo scambio termico e riducendo i depositi di sporco nelle piastre.

Advantages of Brazed Plate Heat Exchangers

- high heat transfer coefficient ;
- small unit size with high heat transfer capacity ;
- high resistance to pressure and temperature fluctuations ;
- stainless steel connections ;
- easy installation ;

Brazed plate heat exchangers consist of stainless steel plate packs, which have embossed chevron patterns.

The plates are turned 180° to each other, causing the plate ridges to intersect, and creating a lattice of intersecting channels. The fluids can flow in counter-current or co-current way.

The entire construction is sealed together by the means of brazing in a special vacuum furnace.

Special corrugation patterns promote high turbulence flow. Turbulence dramatically improves heat transfer rates and reduces the amount of deposits inside the unit.

Flow Channel Diagram in Heat Exchanger

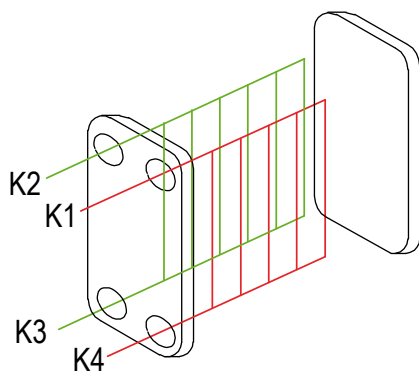

one-pass - channels are parallel

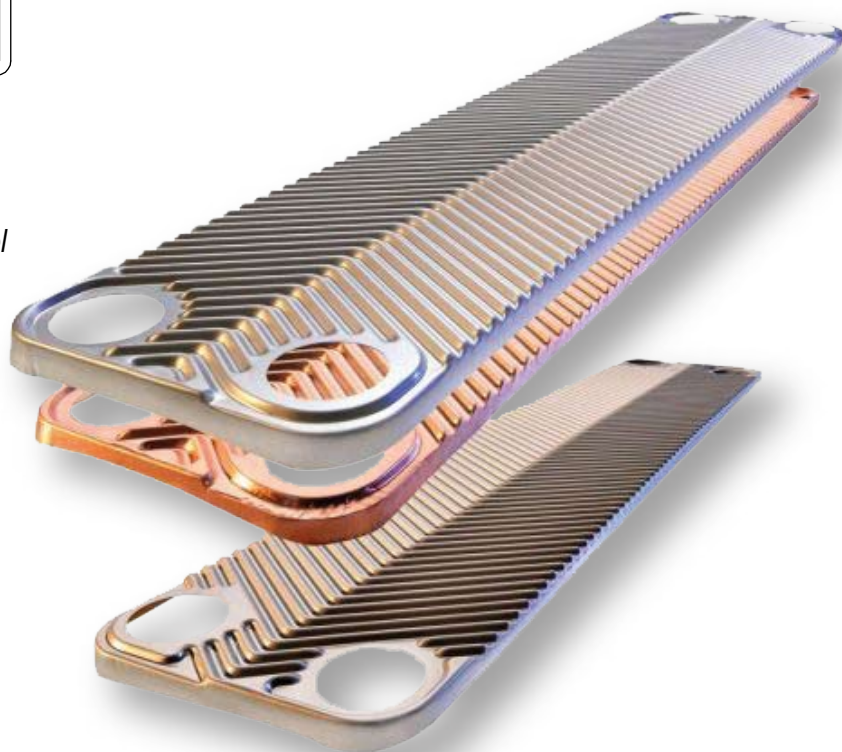

Denominazione codice prodotto

Ordering code



PB **014** **030** **F012** **6**

MODELLO *Model*

SERIE *Series*

- 014
- 022
- 031
- 034
- 047
- 060
- 110
- 170

NUMERO DI PIASTRE *Number of plates*

- 006
- 010
- 020
- 030
- 040
- 050
- 060
- 070
- 080
- 090
- 100
- 110
- 120
- 130
- 140
- 150
- 160
- 170
- 180

CONNESSIONI *Connection Type*

1/2" BSP Femmina (PB014 - PB022 - PB034)
Internal Thread 1/2" BSP

1" BSP Femmina (PB31 - PB047 - PB060)
Internal Thread 1" BSP

2" BSP Maschio (PB110 - PB170)
External Thread 2" BSP

F012

F100

M200



PB014

Dimensioni *Dimensions*



Diagramma rendimento *Performance diagram - ISO VG46 @50°C*

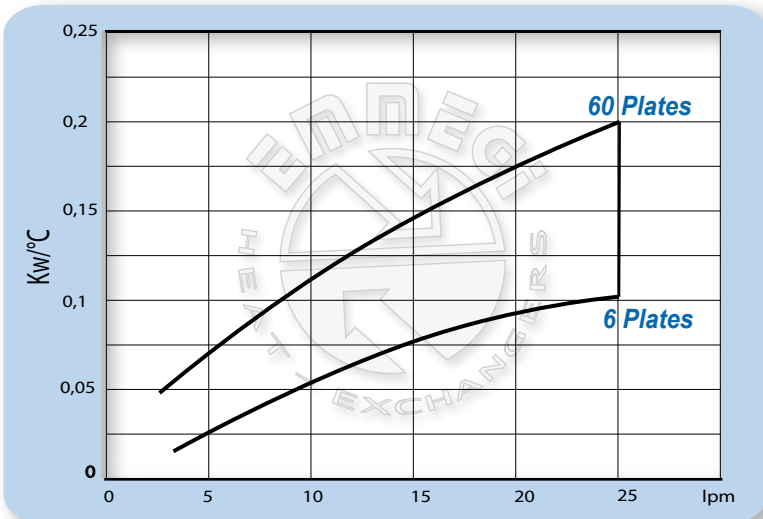

Rapporto portata olio/acqua 2:1 - flow ratio 2:1

Per informazioni inerenti la perdita di carico contattare l' UTEC EMMEGI.
For pressure drop information please contact EMMEGI's technical department.

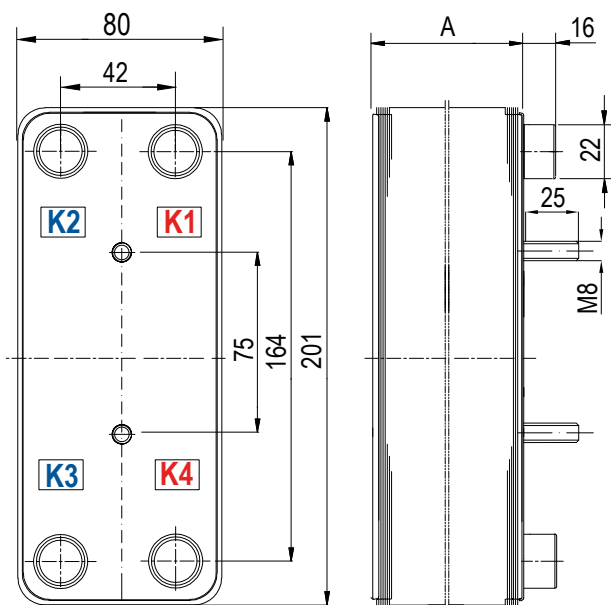

Condizioni di esercizio Working Conditions	
Massima Temperatura Max. Working Pressure	230°C
Minima Temperatura Min. Working Temperature	-10°C
Massima Pressione Max. Working Pressure	30 bar

Materiali Utilizzati Materials	
Piastre Plate	Aisi 316
Attacchi Connection	Aisi 316
Brasatura Brazing Material	Cu 99,95%

Collegamenti Standard Standard of Connection Location	Connessioni Connection Types
K1 / K4 - Ingresso/uscita caldo K1 / K4 - Inlet/Outlet Hot Side	G 1/2" Femmina Internal Thread G 1/2"
K3 / K2 - Ingresso/uscita freddo K3 / K2 - Inlet/Outlet Cold Side	G 1/2" Femmina Internal Thread G 1/2"
A richiesta connessioni speciali Special connections on request	

N° Piastre Plate No.	A (mm)	Peso (Kg) Weight (Kg)	Capacità per circuito lt Channel Volume
6	25	0.97	0.066
10	34	1.15	0.11
20	57	1.6	0.22
30	80	2.05	0.33
40	103	2.5	0.44
50	126	2.95	0.55
60	149	3.4	0.66

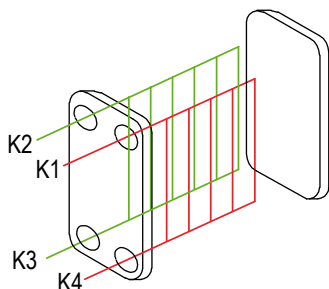

PB014

PB022

Dimensioni *Dimensions*



Diagramma rendimento *Performance diagram - ISO VG46 @50°C*

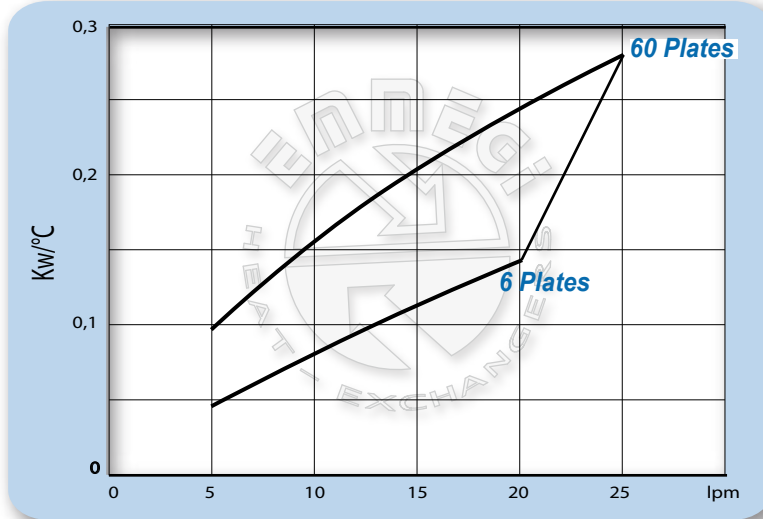

Rapporto portata olio/acqua 2:1 - flow ratio 2:1

Per informazioni inerenti la perdita di carico contattare l' UTEC EMMEGI.
For pressure drop information please contact EMMEGI's technical department.

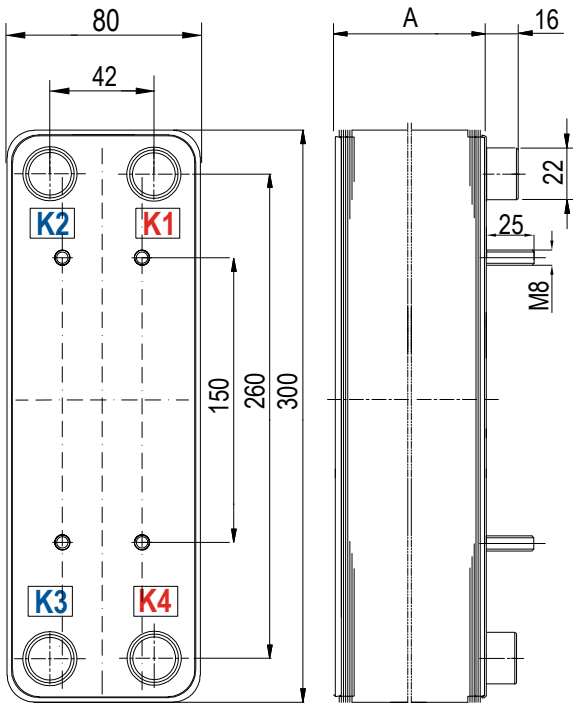

Condizioni di esercizio Working Conditions		Materiali Utilizzati Materials	
Massima Temperatura Max. Working Pressure	230°C	Piastre Plate	Aisi 316
Minima Temperatura Min. Working Temperature	-10°C	Attacchi Connection	Aisi 316
Massima Pressione Max. Working Pressure	30 bar	Brasatura Brazing Material	Cu 99,95%

Collegamenti Standard Standard of Connection Location	Connessioni Connection Types
K1 / K4 - Ingresso/uscita caldo K1 / K4 - Inlet/Outlet Hot Side	G 1/2" Femmina Internal Thread G 1/2"
K3 / K2 - Ingresso/uscita freddo K3 / K2 - Inlet/Outlet Cold Side	G 1/2" Femmina Internal Thread G 1/2"
A richiesta connessioni speciali Special connections on request	

N° Piastre Plate No.	A (mm)	Peso (Kg) Weight (Kg)	Capacità per circuito lt Channel Volume
6	25	1.5	0.105
10	34	1.9	0.175
20	55	2.6	0.35
30	78	3.3	0.525
40	101	4.1	0.7
50	124	4.8	0.875
60	147	5.6	1.05

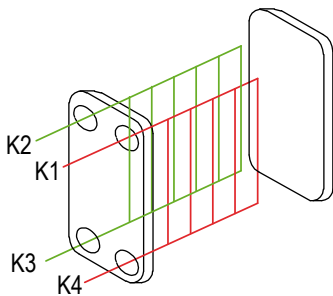

PB022

PB031

Dimensioni Dimensions

Diagramma rendimento Performance diagram - ISO VG46 @50°C

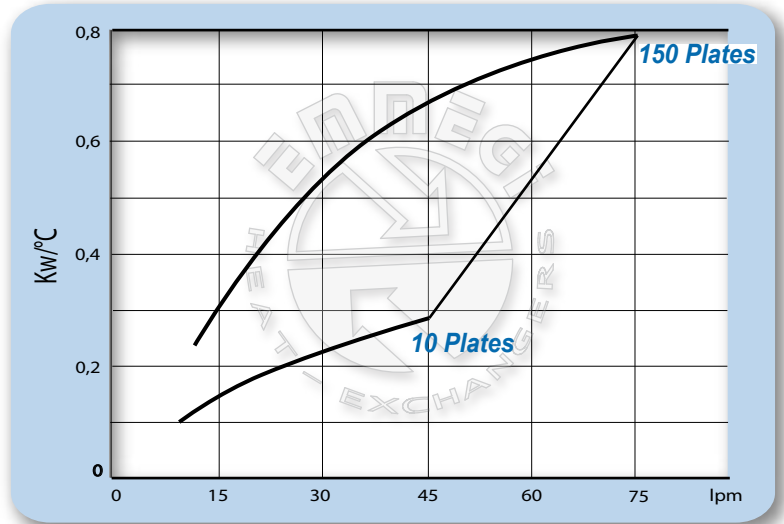

Rapporto portata olio/acqua 2:1 - flow ratio 2:1

Per informazioni inerenti la perdita di carico contattare l' UTEC EMMEGI.
For pressure drop information please contact EMMEGI's technical department.

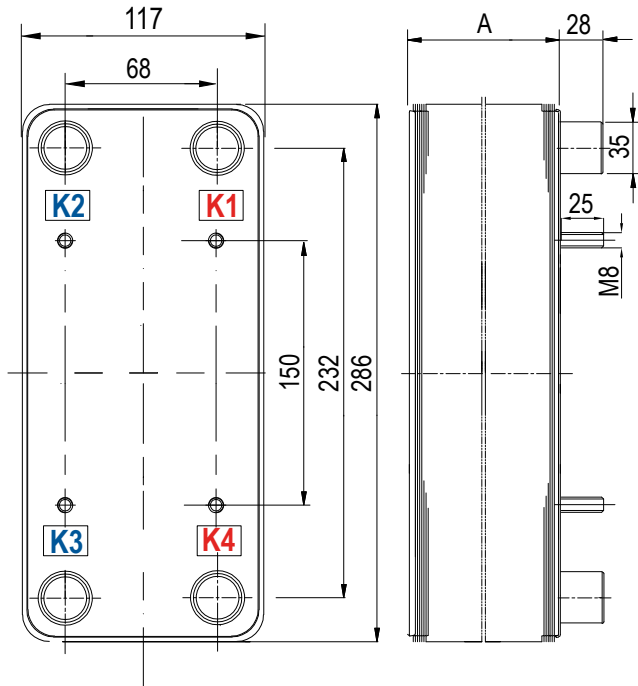

Condizioni di esercizio Working Conditions		Materiali Utilizzati Materials	
Massima Temperatura Max. Working Pressure	230°C	Piastre Plate	Aisi 316
Minima Temperatura Min. Working Temperature	-10°C	Attacchi Connection	Aisi 316
Massima Pressione Max. Working Pressure	30 bar	Brasatura Brazing Material	Cu 99,95%

Collegamenti Standard Standard of Connection Location	Connessioni Connection Types
K1 / K4 - Ingresso/uscita caldo K1 / K4 - Inlet/Outlet Hot Side	G 1" Femmina Internal Thread G 1"
K3 / K2 - Ingresso/uscita freddo K3 / K2 - Inlet/Outlet Cold Side	G 1" Femmina Internal Thread G 1"

A richiesta connessioni speciali
Special connections on request

N° Piastre Plate No.	A (mm)	Peso (Kg) Weight (Kg)	Capacità per circuito It Channel Volume
10	33	3.09	0.24
20	57	4.33	0.47
30	88	5.57	0.76
40	105	6.81	0.94
50	129	8.05	1.18
60	153	9.29	1.41
70	177	10.53	1.65
80	201	11.77	1.88
90	225	13.01	2.16
100	251	14.25	2.35
110	273	15.49	2.59
120	297	16.73	2.82
130	321	17.97	3.06
140	345	19.21	3.29
150	369	20.45	3.53

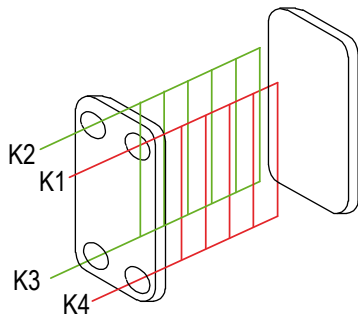

PB031



Diagramma rendimento *Performance diagram - ISO VG46 @50°C*

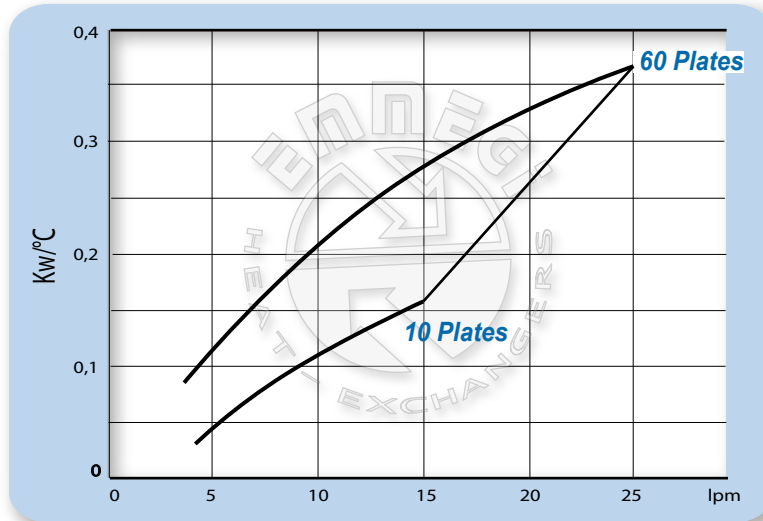

Rapporto portata olio/acqua 2:1 - flow ratio 2:1

Per informazioni inerenti la perdita di carico contattare l' UTEC EMMEGI.
For pressure drop information please contact EMMEGI's technical department.

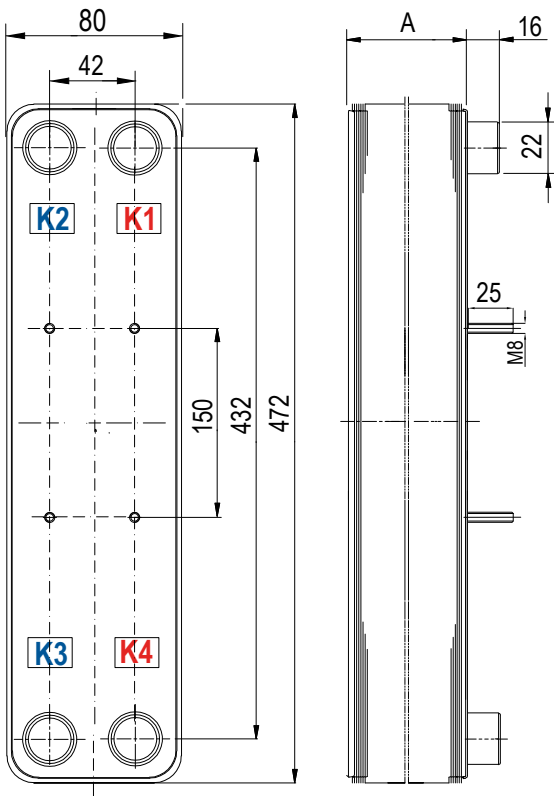

Condizioni di esercizio Working Conditions		Materiali Utilizzati Materials	
Massima Temperatura Max. Working Pressure	230°C	Piastre Plate	Aisi 316
Minima Temperatura Min. Working Temperature	-10°C	Attacchi Connection	Aisi 316
Massima Pressione Max. Working Pressure	30 bar	Brasatura Brazing Material	Cu 99,95%

Collegamenti Standard Standard of Connection Location	Connessioni Connection Types
K1 / K4 - Ingresso/uscita caldo K1 / K4 - Inlet/Outlet Hot Side	G 1/2" Femmina Internal Thread G 1/2"
K3 / K2 - Ingresso/uscita freddo K3 / K2 - Inlet/Outlet Cold Side	G 1/2" Femmina Internal Thread G 1/2"

A richiesta connessioni speciali
Special connections on request

N° Piastre Plate No.	A (mm)	Peso (Kg) Weight (Kg)	Capacità per circuito It Channel Volume
10	32	2.77	0.27
20	55	3.97	0.54
30	78	5.17	0.81
40	101	6.37	1.08
50	124	7.57	1.35
60	147	8.77	1.62

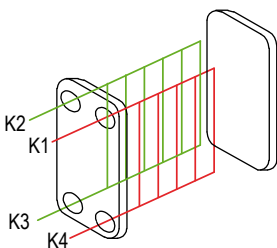

PB034

PB047

Dimensioni Dimensions



Diagramma rendimento Performance diagram - ISO VG46 @50°C

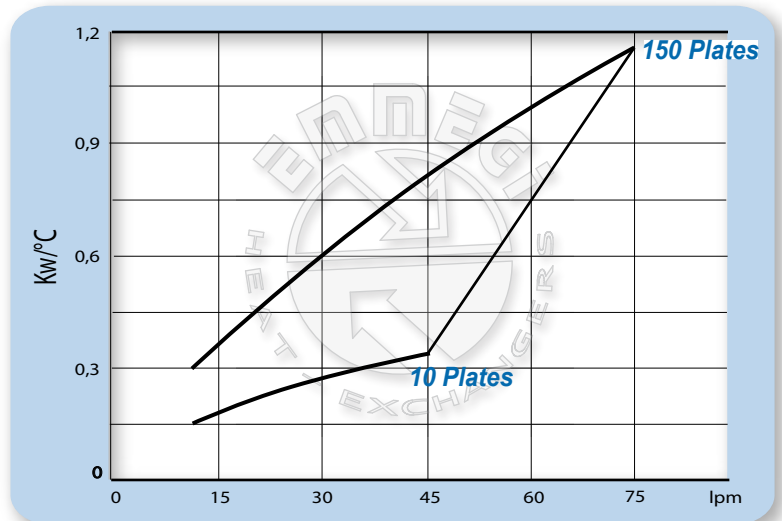

Rapporto portata olio/acqua 2:1 - flow ratio 2:1

Per informazioni inerenti la perdita di carico contattare l' UTEC EMMEGI.
For pressure drop information please contact EMMEGI's technical department.

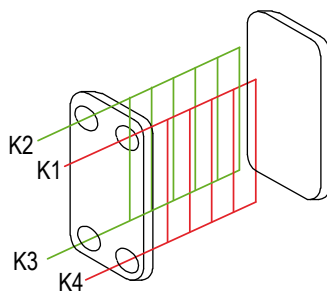
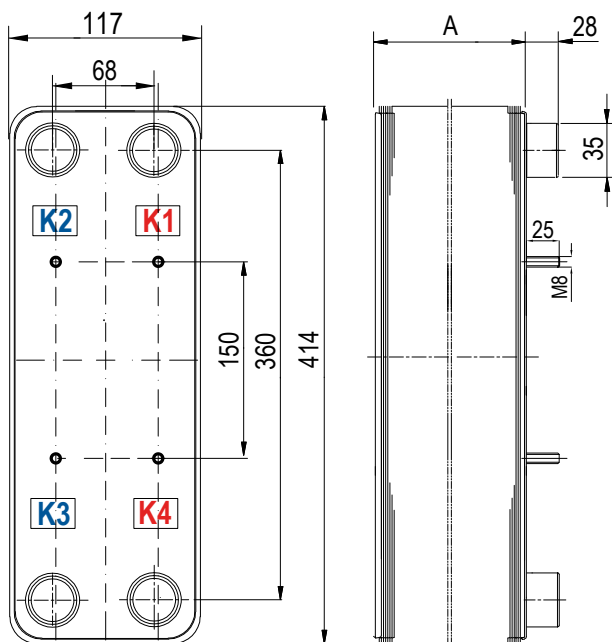

Condizioni di esercizio Working Conditions		Materiali Utilizzati Materials	
Massima Temperatura Max. Working Pressure	230°C	Piastre Plate	Aisi 316
Minima Temperatura Min. Working Temperature	-10°C	Attacchi Connection	Aisi 316
Massima Pressione Max. Working Pressure	30 bar	Brasatura Brazing Material	Cu 99,95%

Collegamenti Standard Standard of Connection Location	Connessioni Connection Types
K1 / K4 - Ingresso/uscita caldo K1 / K4 - Inlet/Outlet Hot Side	G 1" Femmina Internal Thread G 1"
K3 / K2 - Ingresso/uscita freddo K3 / K2 - Inlet/Outlet Cold Side	G 1" Femmina Internal Thread G 1"
A richiesta connessioni speciali Special connections on request	

N° Piastre Plate No.	A (mm)	Peso (Kg) Weight (Kg)	Capacità per circuito It Channel Volume
10	35	4	0.36
20	59	5.9	0.72
30	83	7.8	1.08
40	107	9.7	1.44
50	131	11.6	1.8
60	155	13.5	2.16
70	179	15.4	2.52
80	203	17.3	2.88
90	227	19.2	3.24
100	251	21.1	3.6
110	275	23	3.96
120	299	24.9	4.32
130	323	26.8	4.68
140	347	28.7	5.04
150	371	30.6	5.4

PB047

PB060

Dimensioni *Dimensions*



Diagramma rendimento *Performance diagram - ISO VG46 @50°C*

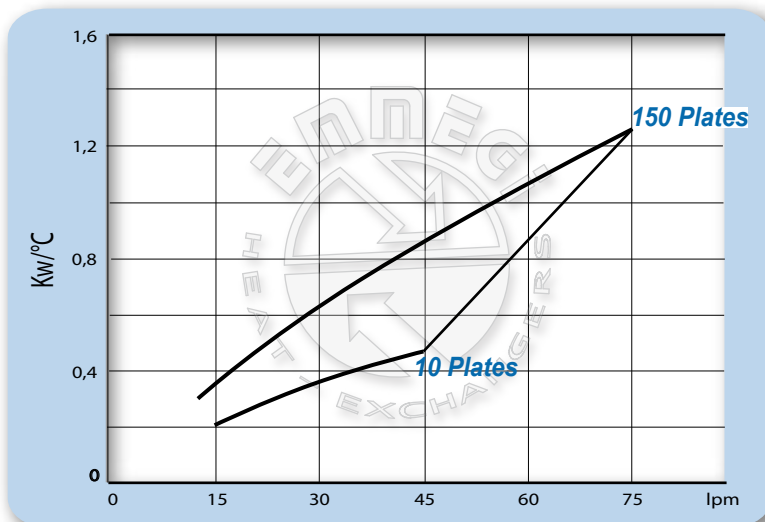

Rapporto portata olio/acqua 2:1 - flow ratio 2:1

Per informazioni inerenti la perdita di carico contattare l' UTEC EMMEGI.
For pressure drop information please contact EMMEGI's technical department.

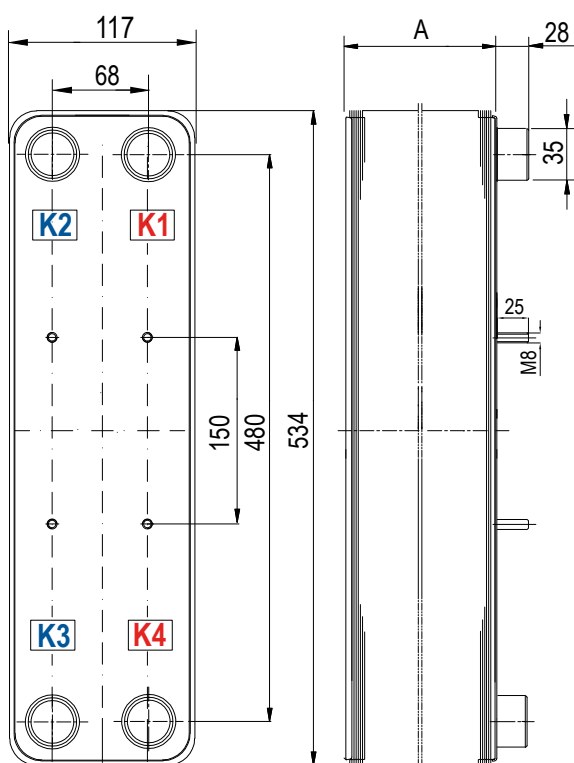

Condizioni di esercizio Working Conditions		Materiali Utilizzati Materials	
Massima Temperatura Max. Working Pressure	230°C	Piastre Plate	Aisi 316
Minima Temperatura Min. Working Temperature	-10°C	Attacchi Connection	Aisi 316
Massima Pressione Max. Working Pressure	30 bar	Brasatura Brazing Material	Cu 99,95%

Collegamenti Standard Standard of Connection Location	Connessioni Connection Types
K1 / K4 - Ingresso/uscita caldo K1 / K4 - Inlet/Outlet Hot Side	G 1" Femmina Internal Thread G 1"
K3 / K2 - Ingresso/uscita freddo K3 / K2 - Inlet/Outlet Cold Side	G 1" Femmina Internal Thread G 1"
A richiesta connessioni speciali Special connections on request	

N° Piastre Plate No.	A (mm)	Peso (Kg) Weight (Kg)	Capacità per circuito lt Channel Volume
10	35	4	0.36
20	59	5.9	0.72
30	83	7.8	1.08
40	107	9.7	1.44
50	131	11.6	1.8
60	155	13.5	2.16
70	179	15.4	2.52
80	203	17.3	2.88
90	227	19.2	3.24
100	251	21.1	3.6
110	275	23	3.96
120	299	24.9	4.32
130	323	26.8	4.68
140	347	28.7	5.04
150	371	30.6	5.4

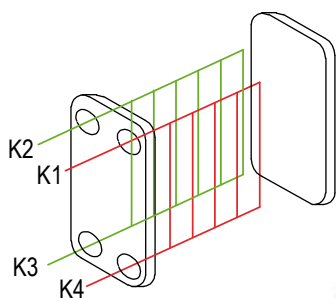

PB110

Dimensioni *Dimensions*



Diagramma rendimento *Performance diagram - ISO VG46 @50°C*

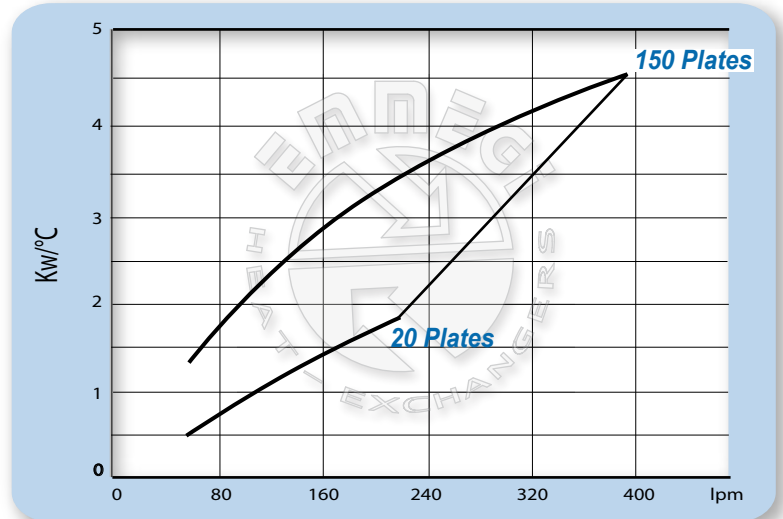

Rapporto portata olio/acqua 2:1 - flow ratio 2:1

Per informazioni inerenti la perdita di carico contattare l' UTEC EMMEGI.
For pressure drop information please contact EMMEGI's technical department.

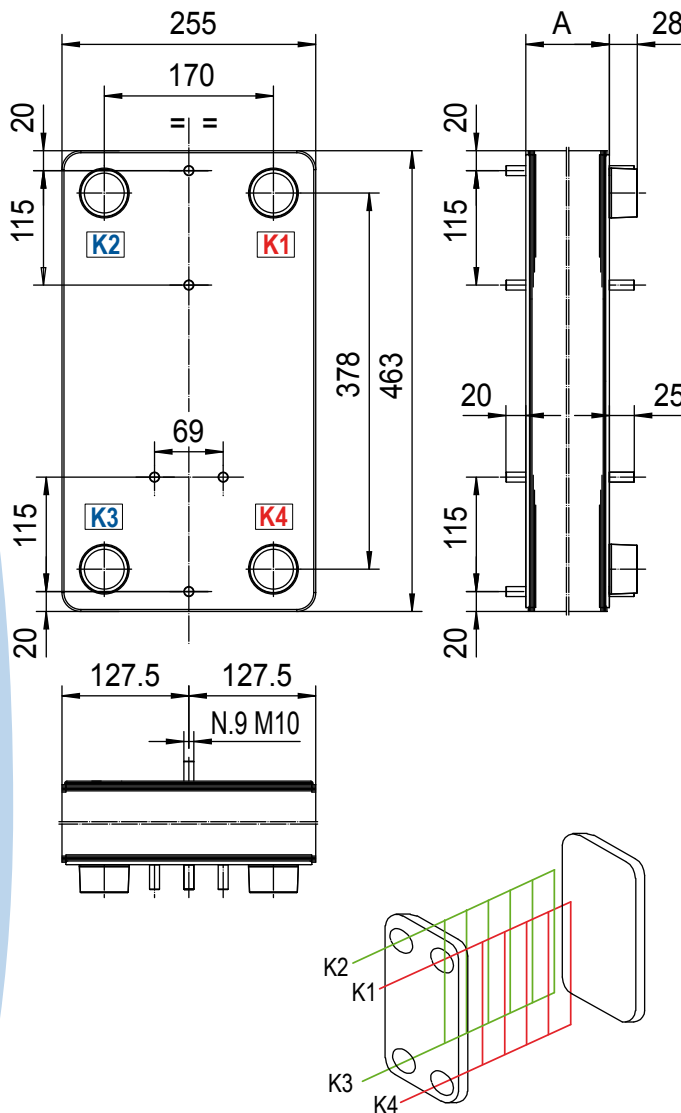

Condizioni di esercizio Working Conditions		Materiali Utilizzati Materials	
Massima Temperatura Max. Working Pressure	230°C	Piastre Plate	Aisi 316
Min. Working Temperature	-10°C	Attacchi Connection	Aisi 316
Max. Working Pressure	23 bar	Brasatura Brazing Material	Cu 99,95%

Collegamenti Standard Standard of Connection Location	Connessioni Connection Types
K1 / K4 - Ingresso/uscita caldo K1 / K4 - Inlet/Outlet Hot Side	G 2" Maschio External Thread G 2"
K3 / K2 - Ingresso/uscita freddo K3 / K2 - Inlet/Outlet Cold Side	G 2" Maschio External Thread G 2"
A richiesta connessioni speciali Special connections on request	

N° Piastre Plate No.	A (mm)	Peso (Kg) Weight (Kg)	Capacità per circuito It Channel Volume
20	58	17	1.62
30	82	21	2.43
40	106	25	3.24
50	130	29	4.05
60	154	33	4.86
70	178	37	5.67
80	202	41	6.48
90	226	45	7.29
100	250	49	8.1
110	274	53	8.91
120	298	57	9.72
130	322	61	10.53
140	346	65	11.34
150	370	69	12.15

PB110

PB170

Dimensioni Dimensions

Diagramma rendimento Performance diagram - ISO VG46 @50°C



PB170

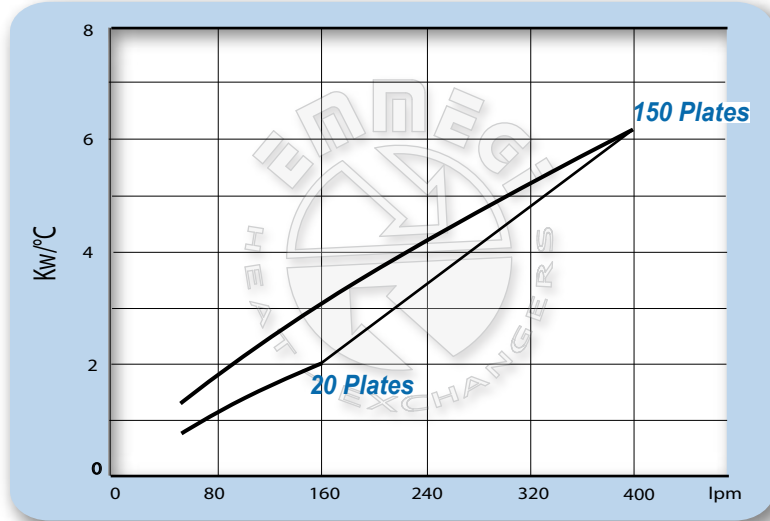

Rapporto portata olio/acqua 2:1 - flow ratio 2:1

Per informazioni inerenti la perdita di carico contattare l' UTEC EMMEGI.
For pressure drop information please contact EMMEGI's technical department.

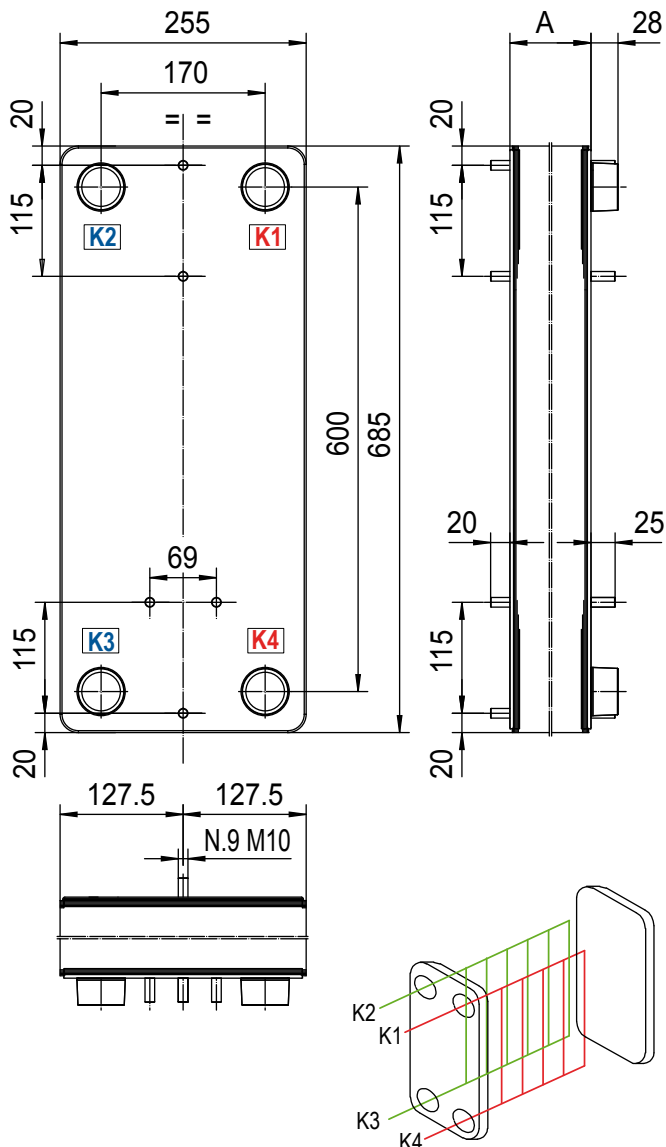

Condizioni di esercizio Working Conditions		Materiali Utilizzati Materials	
Massima Temperatura Max. Working Pressure	230°C	Piastre Plate	Aisi 316
Minima Temperatura Min. Working Temperature	-10°C	Attacchi Connection	Aisi 316
Massima Pressione Max. Working Pressure	23 bar	Brasatura Brazing Material	Cu 99,95%

Collegamenti Standard Standard of Connection Location	Connessioni Connection Types
K1 / K4 - Ingresso/uscita caldo K1 / K4 - Inlet/Outlet Hot Side	G 2" Maschio External Thread G 2"
K3 / K2 - Ingresso/uscita freddo K3 / K2 - Inlet/Outlet Cold Side	G 2" Maschio External Thread G 2"
A richiesta connessioni speciali Special connections on request	

N° Piastre Plate No.	A (mm)	Peso (Kg) Weight (Kg)	Capacità per circuito lt Channel Volume
20	58	17.35	2.55
30	82	23.10	3.83
40	106	28.85	5.10
50	130	34.60	6.38
60	154	40.35	7.65
70	178	46.10	8.93
80	202	51.85	10.20
90	226	57.60	11.48
100	250	63.35	12.75
110	274	69.10	14.03
120	298	74.85	15.30
130	322	80.60	16.58
140	346	86.35	17.85
150	370	92.10	19.13

STAFFE DI FISSAGGIO SERIE PB (ARTICOLO OPTIONAL) *assemblaggio a cura del cliente*

PB Series supporting frame (OPTIONAL) *the assembling is at customer care*

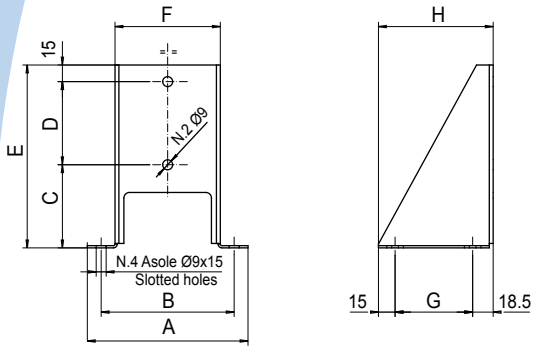

MODELLO MODEL	Dimensioni Dimensions								Staffe di fissaggio Supporting frame
	A	B	C	D	E	F	G	H	P/N
PB014	145	120	75	75	165	95	70	103.5	0533920

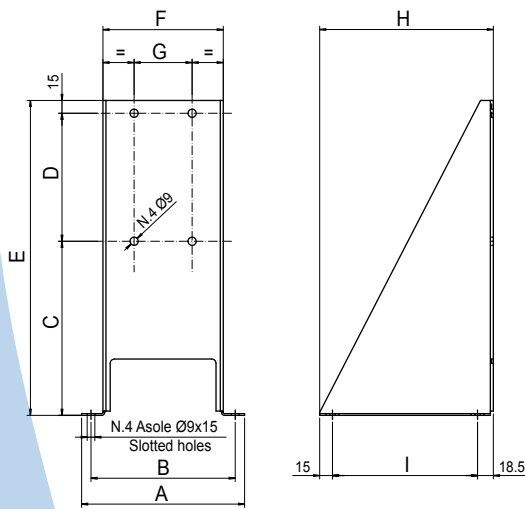

MODELLO MODEL	Dimensioni Dimensions									Staffe di fissaggio Supporting frame
	A	B	C	D	E	F	G	H	I	P/N
PB022	145	120	87	150	252	95	42	103.5	70	0533930
PB031	191	169	80	150	245	141	68	203.5	170	0533940
PB034	145	120	173	150	338	95	42	103.5	70	0533950
PB047	191	169	144	150	309	141	68	203.5	170	0533960
PB060	191	169	204	150	369	141	68	203.5	170	0533970

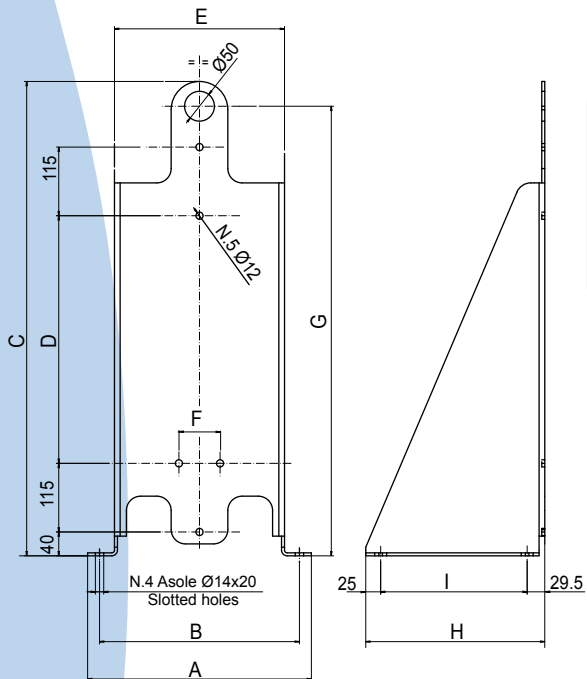

MODELLO MODEL	Dimensioni Dimensions									Staffe di fissaggio Supporting frame
	A	B	C	D	E	F	G	H	I	P/N
PB110	375	335	573	193	285	69	531.5	300	245.5	0533980
PB170	375	335	795	415	285	69	753.5	300	245.5	0533990

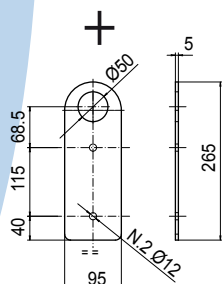

Alla ricerca di un continuo miglioramento del prodotto, EMMEGI S.p.A. si riserva il diritto di approntare modifiche ai dati e alle caratteristiche illustrate nel catalogo.

La riproduzione, anche parziale, del presente catalogo è vietata ai termini di legge.

Questo catalogo sostituisce tutti i precedenti.

As EMMEGI S.p.A. are always investigating methods of improving products and introducing new technology, we reserve the right to modify without notice the data features shown in this catalogue.

The reproduction, even partial of this catalogue is forbidden by law.

This catalogue replace all the previous one.

USA

EMMEGI HEAT EXCHANGERS inc.
(Main Office and Manufacturing)
3606 E.Southern Ave. Suite.2
85040 Phoenix AZ
Ph. +1 602 438 7101
Fax +1 602 438 7127
sales@emmegiinc.com
www.emmegiinc.com

SLOVAKIA

EMMEGI HEAT EXCHANGERS s.r.o
Ul. M. Razusa, 1
95514 Topolcany
Ph. +421 385320739
Fax +421 385320742
sro@emmegi-heat-exchangers.com

GERMANY

EMMEGI GmbH
Philipp - Reis - Str.2
D-41516 Grevenbroich-Kapellen
Germany
Ph. +49 - 2182 - 570 180
Fax. +49 - 2182 - 570 1829
vertrieb@emmegi-gmbh.de
www.emmegi-gmbh.de

TURKEY

EMMEGI HEAT EXCHANGERS
Termal Sistemler Sanayi ve Ticaret Ltd. Őti
8229/2 Sok. No: 12 Odin iŐ Merkezi
ÇiĐli - izmir / Turkey
Ph. +90 232 449 4244
Fax. +90 530 392 7636
kudret@emmegi-turkey.com
www.emmegi-turkey.com

ENGLAND / UK

EMMEGI HEAT EXCHANGERS UK LTD
Unit 820 Jupiter Court, Meteor Business Park
Cheltenham Road Gloucester
GL2 9QW
Ph. +44 01452 540130
Mob. +44 07825 278394
sales@emmegi.co.uk
www.emmegi.co.uk

ASIA / PACIFIC

EMMEGI HEAT EXCHANGERS Ltd
Unit 17.9/ F.Corporation Park,
11 On Lai Street, Siu Lek Yuen,
Shatin, Hong Kong
Ph. + 852 - 26032487
Fax + 852 - 26032119
emmegi@biznetvigator.com

NORDIC AB.

EMMEGI HEAT EXCHANGERS NORDIC AB.
Viadukgatan 8
SE 341 32 Ljungby
Ph. +46 372 86490
www.emmeginordic.se
info@emmeginordic.se

ITALIA

EMMEGI S.p.A
Via Newton 52 - Zona Industriale
20062 Cassano D'Adda (MI) - Italy
Info@emmegi-heat-exchangers.com
www.emmegi-heat-exchangers.com

