

FPE-AMF-AMD

PRESSURE FILTERS



MATERIALS

Head: Aluminium alloy
Spin-on cartridge: Steel
Bypass valve: Polyamide
Seals: NBR Nitrile
(FKM - on request fluoroelastomer)
Indicator housing: Brass

PRESSURE

Max working: 1,2 MPa (12 bar)
Collapse, differential for the filter element (ISO 2941):
400 kPa (4 bar)

BYPASS VALVE

Setting: 170 kPa (1,7 bar) \pm 10%

WORKING TEMPERATURE

From -25° to +110° C

COMPATIBILITY (ISO 2943)

Full with fluids: HH-HL-HM-HR-HV-HTG
(according to ISO 6743/4)
For fluids different than the above mentioned,
please contact our Customer Service.



HYDRAULIC DIAGRAM

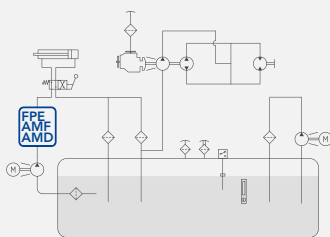

Is this datasheet the latest release? Please check on our website.



ORDERING AND OPTION CHART

F	P	E	COMPLETE FILTER FAMILY	11	12	21	22	31*	32*	41*	42*	FILTER ELEMENT FAMILY	E	S	E
			SIZE & LENGHT									SIZE & LENGHT			
			PORT TYPE												
			B = BSP thread	B	B	B	B	B	B	B	B				
			F = SAE flange 3000 psi	-	-	-	-	-	-	F	F				
			PORT SIZE												
			06 = 3/4"	06	06	-	-	-	-	-	-				
			10 = 1" 1/4	-	-	10	10	-	-	-	-				
			12 = 1" 1/2	-	-	-	-	12	12	12	12				
			BYPASS VALVE												
			W = without	W	W	W	W	W	W	W	W				
			B = 170 kPa (1,7 bar)	B	B	B	B	B	B	B	B				
			SEALS									SEALS			
			N = NBR Nitrile	N	N	N	N	N	N	N	N				
			F = FKM Fluoroelastomer	F	F	F	F	F	F	F	F				
			FILTER MEDIA									FILTER MEDIA			
			FA = fibreglass 5 µm(c) β>1.000	FA	FA	FA	FA	FA	FA	FA	FA				
			FB = fibreglass 7 µm(c) β>1.000	FB	FB	FB	FB	FB	FB	FB	FB				
			FC = fibreglass 12 µm(c) β>1.000	FC	FC	FC	FC	FC	FC	FC	FC				
			FD = fibreglass 21 µm(c) β>1.000	FD	FD	FD	FD	FD	FD	FD	FD				
			CC = impregnated cellulose 10 µm β>2	CC	CC	CC	CC	CC	CC	CC	CC				
			CD = impregnated cellulose 25 µm β>2	CD	CD	CD	CD	CD	CD	CD	CD				
			CLOGGING INDICATOR												
			06 = port, plugged	06	06	06	06	06	06	06	06				
			31 = pressure gauge, rear connection	31	31	31	31	31	31	31	31				
			P1 =SPDT, pressure switch	P1	P1	P1	P1	P1	P1	P1	P1				
X	X		ACCESSORIES												
			XX = no accessory available	XX	XX	XX	XX	XX	XX	XX	XX				

SPARE PARTS ELEMENTS

FILTER HOUSING				FILTER ELEMENT				CLOGGING INDICATOR			
B	P	E		E	S	E					



AMF

PRESSURE FILTERS



ORDERING AND OPTION CHART

A	M	F	COMPLETE FILTER FAMILY							FILTER ELEMENT FAMILY	C	C	A		
			SIZE & LENGHT	151	152	301	302	601*	602*	801*	802*	SIZE & LENGHT			
			FILTER MEDIA							FILTER MEDIA					
			FT = fibreglass 5 µm(c) β>1.000	FT	FT	FT	FT	FT	FT	FT	FT				
			FC = fibreglass 7 µm(c) β>1.000	FC	FC	FC	FC	FC	FC	FC	FC				
			FD = fibreglass 12 µm(c) β>1.000	FD	FD	FD	FD	FD	FD	FD	FD				
			FV = fibreglass 21 µm(c) β>1.000	FV	FV	FV	FV	FV	FV	FV	FV				
			CD = impregnated cellulose 10 µm(c) β>2	CD	CD	CD	CD	CD	CD	CD	CD				
			CV = impregnated cellulose 25 µm(c) β>2	CV	CV	CV	CV	CV	CV	CV	CV				
			SEALS							SEALS					
			1 = NBR 1itrile	1	1	1	1	1	1	1	1				
			2 = FKM Fluoroelastomer	2	2	2	2	2	2	2	2				
			BYPASS VALVE												
			S = without	S	S	S	S	S	S	S	S				
			B = 170 kPa (1,7 bar)	B	B	B	B	B	B	B	B				
			PORT TYPE												
			B = BSP thread	B	B	B	B	B	B	B	B				
			F = SAE flange 3000 psi	-	-	F	F	F	F	F	F				
			PORT SIZE												
			4 = 3/4"	4	4	-	-	-	-	-	-				
			6 = 1" 1/4	-	-	6	6	-	-	-	-				
			7 = 1" 1/2	-	-	-	-	7	7	7	7				
			CLOGGING INDICATOR												
			06 = port, plugged	06	06	06	06	06	06	06	06				
			31 = pressure gauge, rear connection	31	31	31	31	31	31	31	31				
			P1 =SPDT, pressure switch	P1	P1	P1	P1	P1	P1	P1	P1				
X	X		ACCESSORIES												
			XX = no accessory available	XX	XX	XX	XX	XX	XX	XX	XX				

NOTE

* When ordering the filter elements, please consider the following information:

ESE31 = 2 x ESE21

ESE32 = 2 x ESE22

ESE41 = 2 x ESE21

ESE42 = 2 x ESE22

CCA601 = 2 X CCA301

CCA602 = 2 X CCA302

CCA801 = 2 X CCA301

CCA802 = 2 X CCA302

ORDERING AND OPTION CHART - VERSION WITH DIFFERENTIAL INDICATOR

F	P	E	COMPLETE FILTER FAMILY									FILTER ELEMENT FAMILY	E	S	E
			SIZE & LENGHT	A1*	A2*	B1*	B2*	31*	32*	41*	42*	SIZE & LENGHT			
			PORT TYPE												
			B = BSP thread	B	B	B	B	B	B	B	B	B			
			F = SAE flange 3000 psi	-	-	-	-	-	-	F	F				
			PORT SIZE												
			06 = 3/4"	06	06	-	-	-	-	-	-	-			
			10 = 1" 1/4	-	-	10	10	-	-	-	-				
			12 = 1" 1/2	-	-	-	-	12	12	12	12				
			BYPASS VALVE												
			W = without	W	W	W	W	W	W	W	W	W			
			B = 170 kPa (1,7 bar)	B	B	B	B	B	B	B	B	B			
			SEALS												
			N = NBR Nitrile	N	N	N	N	N	N	N	N	N			
			F = FKM Fluoroelastomer	F	F	F	F	F	F	F	F	F			
			FILTER MEDIA												
			FA = fibreglass 5 µm(c) β>1.000	FA	FA	FA	FA	FA	FA	FA	FA	FA			
			FB = fibreglass 7 µm(c) β>1.000	FB	FB	FB	FB	FB	FB	FB	FB	FB			
			FC = fibreglass 12 µm(c) β>1.000	FC	FC	FC	FC	FC	FC	FC	FC	FC			
			FD = fibreglass 21 µm(c) β>1.000	FD	FD	FD	FD	FD	FD	FD	FD	FD			
			CC = impregnated cellulose 10 µm β>2	CC	CC	CC	CC	CC	CC	CC	CC	CC			
			CD = impregnated cellulose 25 µm β>2	CD	CD	CD	CD	CD	CD	CD	CD	CD			
			CLOGGING INDICATOR**												
			03 = port, plugged	-	-	-	-	03	03	03	03	03			
			5B = visual differential 130 kPa (1,3 bar)	-	-	-	-	5B	5B	5B	5B	5B			
			6B = electrical differential 130 kPa (1,3 bar)	-	-	-	-	6B	6B	6B	6B	6B			
			7B = indicator 6B with LED	-	-	-	-	7B	7B	7B	7B	7B			
			T0 = elect. diff. 130 kPa (1,3 bar) with thermostat 30°C	-	-	-	-	T0	T0	T0	T0	T0			
			0U = ports, plugged	0U	0U	0U	0U	-	-	-	-	-			
			U0 = visual differential 130 kPa (1,3 bar)	U0	U0	U0	U0	-	-	-	-	-			
			N0 = visual-electrical differential 130 kPa (1,3 bar)	N0	N0	N0	N0	-	-	-	-	-			
X	X		ACCESSORIES												
			XX = no accessory available	XX	XX	XX	XX	XX	XX	XX	XX	XX	XX		

SPARE PARTS ELEMENTS

FILTER HOUSING				FILTER ELEMENT				CLOGGING INDICATOR			
B	P	E		E	S	E					



AMD

PRESSURE FILTERS



ORDERING AND OPTION CHART - VERSION WITH DIFFERENTIAL INDICATOR

A	M	D	COMPLETE FILTER FAMILY									FILTER ELEMENT FAMILY	C	C	A
			SIZE & LENGHT	151	152	301	302	601	602	801	802	SIZE & LENGHT			
			FILTER MEDIA									FILTER MEDIA			
			FT = fibreglass 5 µm(c) β>1.000	FT	FT	FT	FT	FT	FT	FT	FT				
			FC = fibreglass 7 µm(c) β>1.000	FC	FC	FC	FC	FC	FC	FC	FC				
			FD = fibreglass 12 µm(c) β>1.000	FD	FD	FD	FD	FD	FD	FD	FD				
			FV = fibreglass 21 µm(c) β>1.000	FV	FV	FV	FV	FV	FV	FV	FV				
			CD = impregnated cellulose 10 µm β>2	CD	CD	CD	CD	CD	CD	CD	CD				
			CV = impregnated cellulose 25 µm β>2	CV	CV	CV	CV	CV	CV	CV	CV				
			SEALS									SEALS			
			1 = NBR Nitrile	1	1	1	1	1	1	1	1				
			2 = FKM Fluoroelastomer	2	2	2	2	2	2	2	2				
			BYPASS VALVE												
			S = without	S	S	S	S	S	S	S	S				
			B = 170 kPa (1,7 bar)	B	B	B	B	B	B	B	B				
			PORT TYPE												
			B = BSP thread	B	B	B	B	B	B	B	B				
			F = SAE flange 3000 psi	-	-	-	-	-	-	F	F				
			PORT SIZE												
			4 = 3/4" (F06 not available)	4	4	-	-	-	-	-	-				
			6 = 1" 1/4 (N10 not available)	-	-	6	6	-	-	-	-				
			7 = 1" 1/2 (G12 option not available)	-	-	-	-	7	7	7	7				
			CLOGGING INDICATOR **												
			03 = port, plugged	-	-	-	-	03	03	03	03				
			5B = visual differential 130 kPa (1,3 bar)	-	-	-	-	5B	5B	5B	5B				
			6B = electrical differential 130 kPa (1,3 bar)	-	-	-	-	6B	6B	6B	6B				
			7B = indicator 6E with LED	-	-	-	-	7B	7B	7B	7B				
			T0 = elect. diff. 130 kPa (1,3 bar) with thermostat 30°C	-	-	-	-	T0	T0	T0	T0				
			0U = ports, plugged	0U	0U	0U	0U	-	-	-	-				
			U0 = visual differential 130 kPa (1,3 bar)	U0	U0	U0	U0	-	-	-	-				
			N0 = visual-electrical differential 130 kPa (1,3 bar)	N0	N0	N0	N0	-	-	-	-				
X	X		ACCESSORIES												
			XX = no accessory available	XX	XX	XX	XX	XX	XX	XX	XX				

NOTE

* When ordering the filter elements, please consider the following information:

- | | |
|-------------------|---------------------|
| ESEA1 = ESE11 | CCA601 = 2 X CCA301 |
| ESEA2 = ESE12 | CCA602 = 2 X CCA302 |
| ESEB1 = ESE21 | CCA801 = 2 X CCA301 |
| ESEB2 = ESE22 | CCA802 = 2 X CCA302 |
| ESE31 = 2 x ESE21 | |
| ESE32 = 2 x ESE22 | |
| ESE41 = 2 x ESE21 | |
| ESE42 = 2 x ESE22 | |

** When the filter is ordered with FKM seals, the first digit of the indicator code is a letter (please see Clogging Indicator Chapter for further details)

FPE-AMF-AMD

PRESSURE FILTERS



INSTALLATION DRAWING

FPE 1+ & FPE 2+

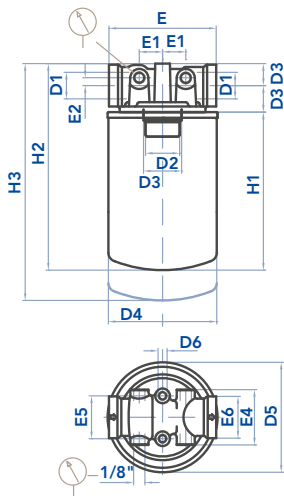

FPE 3+

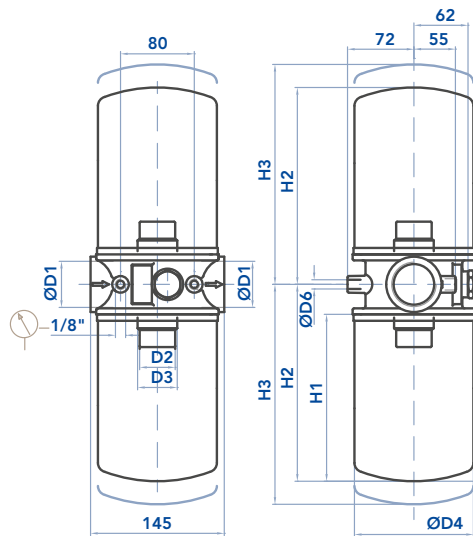

FPE 4+

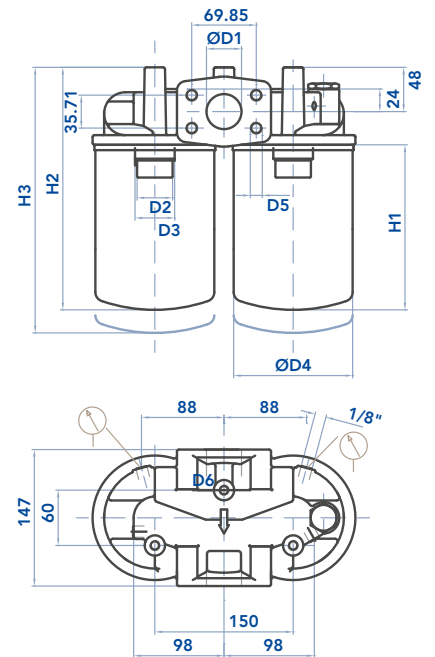

FPE A+ & FPE B+

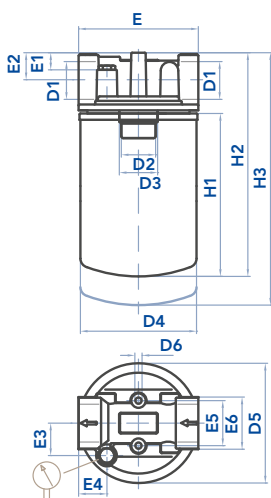

FPE 3+

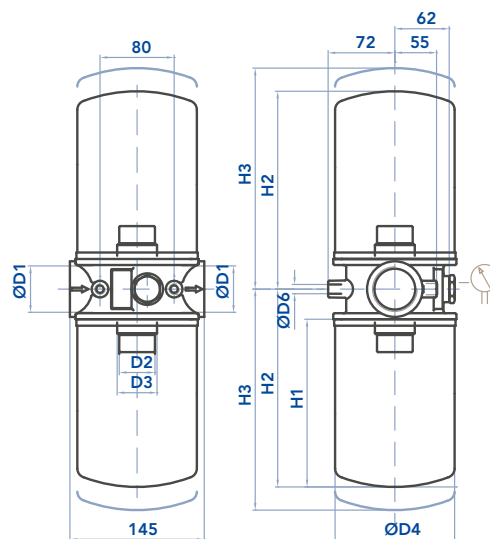

FPE 4+

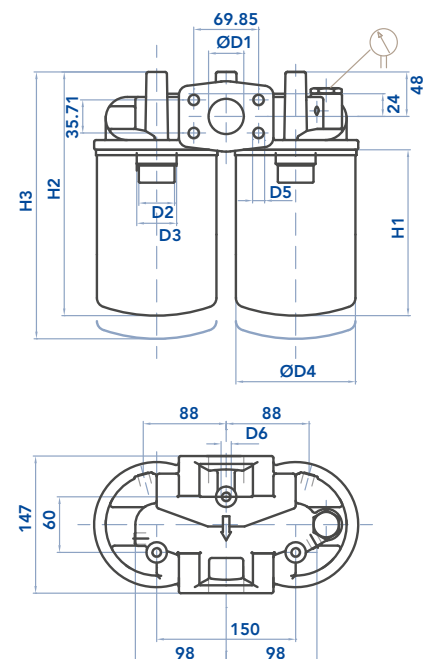



FILTER HOUSING

	D1	D2	D3	D4	D5	D6	E	E1	E2	E3	E4	E5	E6	H1	H2	H3	Kg
FPE11 AMF151	3/4"	3/4" BSP	-	96	96	M8	95	20,5	7	20	48	38	37	145	188	208	1,2
FPE12 AMF152	3/4"	3/4" BSP	-	96	96	M8	95	20,5	7	20	48	38	37	191	234	254	1,5
FPE21 AMF301	1"1/4	1"1/2 16 UN	1"1/4 BSP	129	134	M8	133	35	10	30	64	50	57	181	248	278	1,9
FPE31 AMF601	1"1/2	1"1/2 16 UN	1"1/4 BSP	129	-	M10	-	-	-	-	-	-	-	181	216	246	3,6
FPE41 AMF601	1"1/2	1"1/2 16 UN	1"1/4 BSP	129	M12	M10	-	-	-	-	-	-	-	181	269	299	4,8
FPE22 AMF302	1"1/4	1"1/2 16 UN	1"1/4 BSP	129	134	M8	133	35	10	30	64	50	57	226	293	323	2,0
FPE32 AMF602	1"1/2	1"1/2 16 UN	1"1/4 BSP	129	-	M10	-	-	-	-	-	-	-	226	261	291	3,8
FPE42 AMF602	1"1/2	1"1/2 16 UN	1"1/4 BSP	129	M12	M10	-	-	-	-	-	-	-	226	314	344	5,0

FILTER HOUSING - VERSIN WITH DIFFERENTIAL INDICATOR

	D1	D2	D3	D4	D5	D6	E	E1	E2	E3	E4	E5	E6	H1	H2	H3	Kg
FPEA1 AMD151	3/4"	3/4" BSP	-	96	96	M8	95	-	23	24,5	21,5	38	32	145	188	208	1,2
FPEA2 AMD152	3/4"	3/4" BSP	-	96	96	M8	95	-	23	24,5	21,5	38	32	191	234	254	1,5
FPEB1 AMD301	1"1/4	1"1/2 16-UN	1"1/4 BSP	129	134	M8	133	19	30	36	35	50	54	181	248	278	1,9
FPE31 AMD601	1"1/2	1"1/2 16-UN	1"1/4 BSP	129	-	M10	-	-	-	-	-	-	-	181	216	246	3,6
FPE41 AMD801	1"1/2	1"1/2 16-UN	1"1/4 BSP	129	M12	M10	-	-	-	-	-	-	-	181	269	299	4,8
FPEB2 AMD302	1"1/4	1"1/2 16-UN	1"1/4 BSP	129	134	M8	133	19	30	36	35	50	54	226	293	323	2,0
FPE32 AMD602	1"1/2	1"1/2 16-UN	1"1/4 BSP	129	-	M10	-	-	-	-	-	-	-	226	261	291	3,8
FPE42 AMD802	1"1/2	1"1/2 16-UN	1"1/4 BSP	129	M12	M10	-	-	-	-	-	-	-	226	314	344	5,0

MAINTENANCE

The best time to change your filter element is just before it reaches its maximum dirt-holding capacity. For this reason, we recommend to monitor the pressure of the hydraulic oil flowing through the filter with a clogging indicator. When it is time to change the filter element, switch off the system and make sure there is no pressure in the filter. Remove the dirty filter element. Replace it with an original UFI element, verifying

the part number on the filter label or on the catalogue. Lubricate the spin-on gasket, screw on the head until it stops and tighten by turning it 3/4 of a turn

We recommend the stocking of a spare UFI filter element for timely replacement when required.

FPE-AMF-AMD

PRESSURE FILTERS

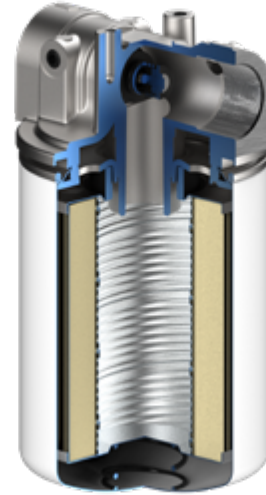
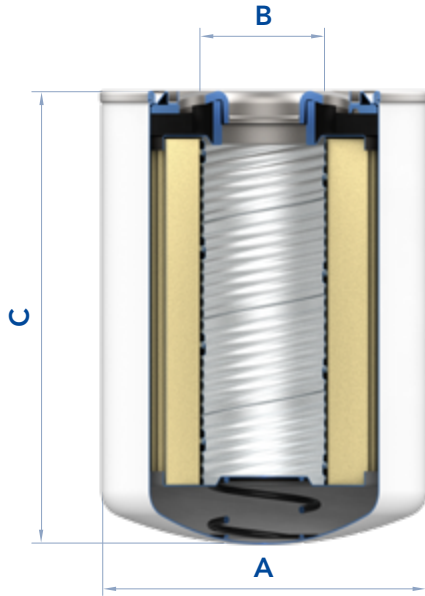

FILTER ELEMENT

	A	B	C	Kg	AREA (cm ²)	
					Media F+	MediaC+
ESE11 CCA151	96,5	3/4" BSP	146	0,70	2.140	3.305
ESE12 CCA152	96,5	3/4" BSP	191	0,80	3.630	4.745
ESE21 CCA301	129	1"1/4 BSP	181	1,20	4.450	5.560
ESE22 CCA302	129	1"1/4 BSP	226	1,40	5.890	7.360

The used filter elements cannot be cleaned and are classified as "Dangerous waste material". They must be disposed according to local laws by authorized Companies. Verify that the Company you choose has the expertise and authorization to dispose this type of waste material.

PRESSURE DROP CURVES (Δp)

The "Assembly Pressure Drop (Δp)" is obtained by adding the pressure drop values of the Filter Housing and of the Clean Filter Element corresponding to the considered Flow

Rate and it must be lower than 50 kPa (0,5 bar) and should never exceed 1/3 of the bypass valve setting.

FILTER HOUSING PRESSURE DROP
(mainly depending on the port size)

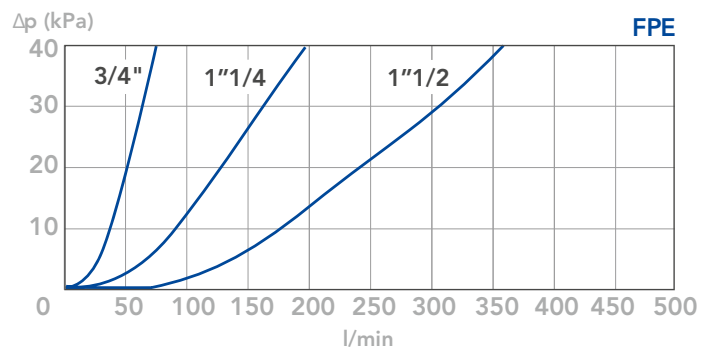

CLEAN FILTER ELEMENT PRESSURE DROP WITH F+ AND C+ MEDIA
(depending both on the internal diameter of the element and on the filter media)

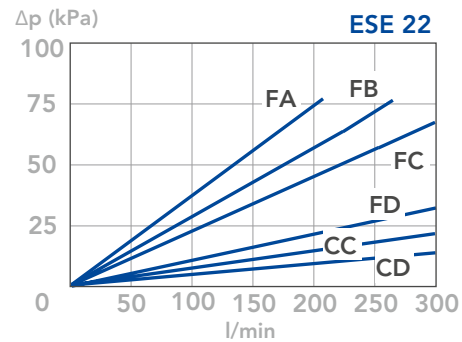
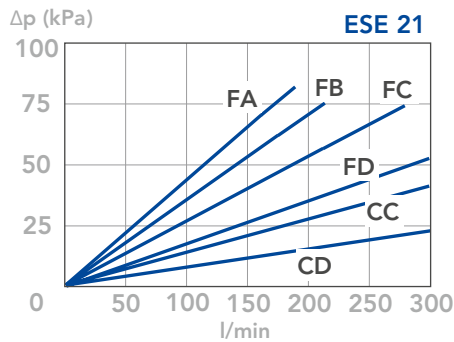
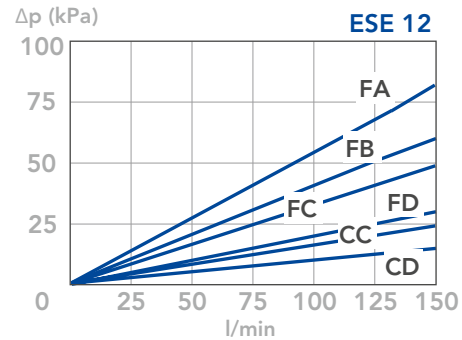
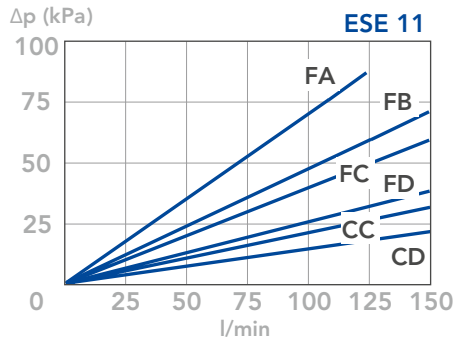

BYPASS VALVE PRESSURE DROP

When selecting the filter size, these curves must be taken into account if it is foreseen that any flow peak is to be absorbed by the bypass valve, it also must be of proper configuration to avoid pressure peaks. The valve pressure drop is directly proportional to fluid specific gravity.

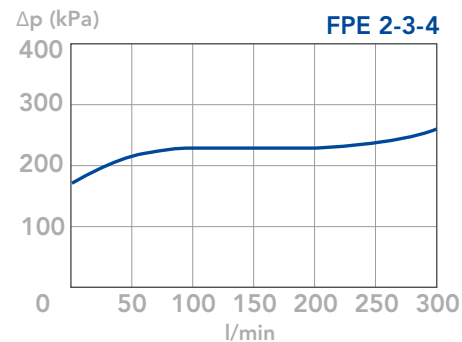
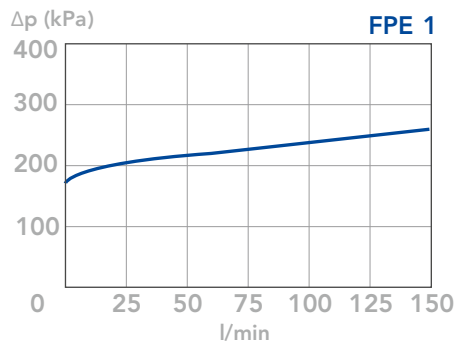

N.B.

All the curves have been obtained with mineral oil having a kinematic viscosity 30 cSt and specific gravity 0,86 Kg/dm³; for fluids with different features, please consider the factors described in the first part of this catalogue. All the curves

are obtained from test done at the UFI HYDRAULIC DIVISION Laboratory, according to the specification ISO 3968. In case of discrepancy, please check the contamination level, viscosity and features of the fluid in use.