

R8 D

U

T

Y

HEAVY

1

DISPLACEMENT

 **Italgroupp**[®]

HYDRAULIC MOTORS

 ITALY

HEAVY DUTY SINGLE DISPLACEMENT HYDRAULIC MOTOR



R8D SERIES TECHNICAL CATALOGUE

The data specified into the catalogue are for product description purpose only and must not be interpreted as warranted characteristics in legal sense. ItalgrouP S.r.l. reserves the right to implement modifications without notice.

All partial or total reproduction and copy without written authorization of ItalgrouP S.r.l. is strictly forbidden.

©2018 ITALGROUP S.R.L. - ALL RIGHTS RESERVED -

GENERAL INDEX

FORMULAS	Pag. 3
INTRODUCTION - GENERAL INFORMATION	Pag. 4 - 5
MOTOR TECHNICAL DATA	Pag. 6 - 7
INTERCHANGEABILITY CHART	Pag. 8
R8D ORDERING CODE	Pag. 9
HYDRAULIC FLUID RECOMMENDATIONS	Pag. 10 - 11
DRAIN RECOMMENDATIONS - FLUSHING	Pag. 12 - 13
STANDARD SHAFT SEAL FEATURES	Pag. 14 - 15
MOTOR INSTALLATION AND STARTUP	Pag. 16 - 18
MOTOR HANDLING AND STORAGE	Pag. 19 - 20
MAINTENANCE OPERATION	Pag. 21
INSTRUCTION AND ADVICES	Pag. 22
SPECIAL FEATURES	Pag. 23
TROUBLESHOOTING	Pag. 24 - 25
UNIT CONVERSIONS	Pag. 26
R8D H2	Pag. 27 - 36
R8D H3	Pag. 37 - 50
R8D H4	Pag. 51 - 69
R8D H45	Pag. 71 - 79
R8D H5	Pag. 79 - 99
R8D H55	Pag. 101 - 113
R8D H6	Pag. 115 - 133
R8D H7	Pag. 135 - 149
R8D H8	Pag. 151 - 162
R8D H9	Pag. 163 - 173
MOTOR DISTRIBUTORS	Pag. 174 - 175
TACHOMETERS	Pag. 177 - 180
SPLINED BILLETS - SPLINED BARS	Pag. 181 - 185
ADAPTOR FLANGES	Pag. 186 - 187
VALVES	Pag. 189 - 206
CONTACT US - REACH US	Pag. 207

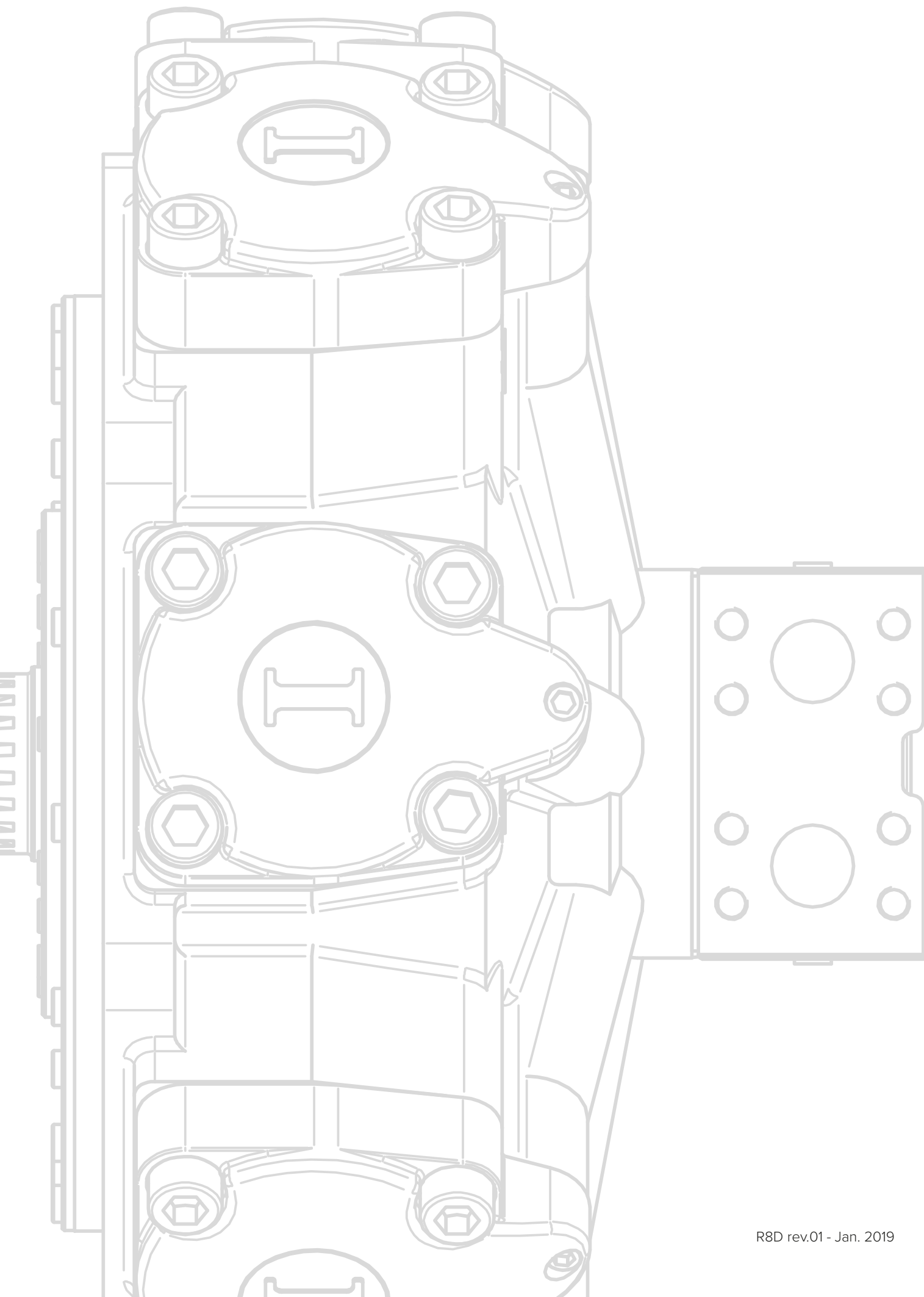

FORMULAS

$$\text{Torque [Nm]} = \text{Specific torque [Nm/bar]} * \text{Pressure [bar]}$$

$$\text{Torque [Nm]} = \frac{\text{Displacement [cc/Rev]} * \text{Pressure [bar]}}{62.8}$$

$$\text{Power [kW]} = \frac{\text{Torque [Nm]} * \text{Speed [rpm]}}{9549}$$

$$\text{Power [CV]} = \frac{\text{Torque [Nm]} * \text{Speed [rpm]}}{7023}$$

$$\text{Speed [rpm]} = \frac{\text{Flow [l/min]} * 1000}{\text{Displacement [cc/Rev]}}$$

$$\text{Displacement [cc/Rev]} = \frac{\text{Torque [Nm]} * 62.8}{\text{Pressure [bar]}}$$

$$\text{Flow [l/min]} = \frac{\text{Displacement [cc/Rev]} * \text{Speed [rpm]}}{1000}$$

INTRODUCTION

GENERAL INFORMATION

Carefully read the use and maintenance manual before start-up the motor. The use and maintenance manual must be placed near to motor installation location in order to guarantee operators easy access to the instruction manual. For further information please contact Italgrou.

MOTOR DESCRIPTION

R8D series motors are radial piston hydraulic motors (generally indicated as LSHT motors, low speed high torque motors) with a rotating shaft (1) and a stationary housing (2). The pistons (4) are located radially and the working fluid provide the mechanical force that push the pistons against the eccentric shaft, providing the shaft output torque. The inlet and outlet flow to and from the pistons is regulated by a distributor (5), that provides the oil distribution correct timing. The pistons transfer the forces to the eccentric shaft through a connecting rod (3). Acting in the adequate way (increasing or reducing the oil flow coming from the pump) the motor rotational speed can be increased or reduced. The motor design guarantee extremely high starting torque and high mechanical working efficiency. Respecting the limitation of working parameters (indicated into the technical datasheets) and all recommendations (including fluid recommendations), high motor lifetimes are obtained and very low maintenance requirements are needed.

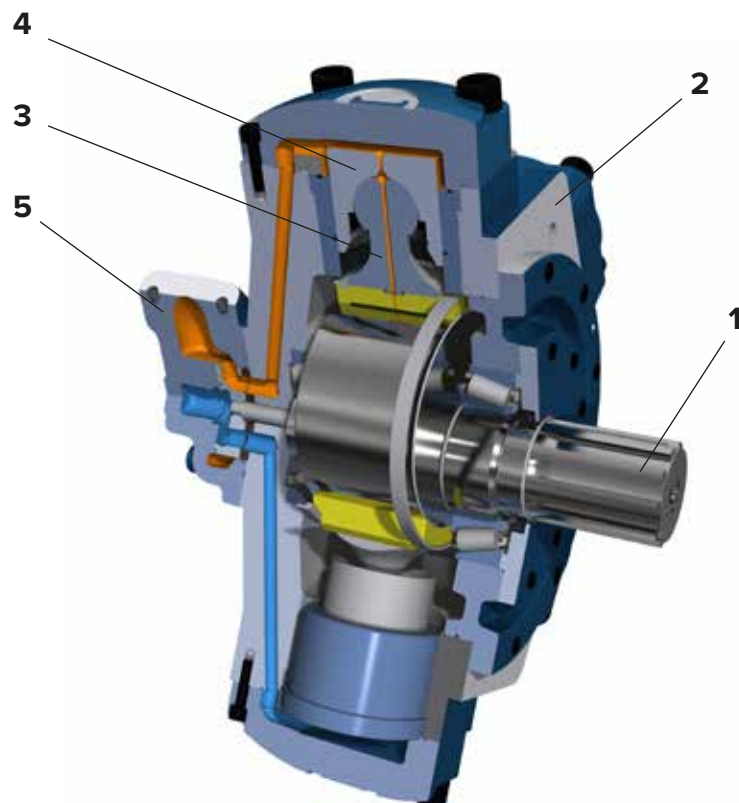

R8D SERIES

Hydraulic motors of the R8D series are single displacement crankshaft radial piston motors. Thanks to great variety of accessories R8D series can be used in a wide range of applications such as:



- MARINE EQUIPMENTS
- WINCHES
- OFFSHORE EQUIPMENTS
- CONVEYORS
- INJECTION MOULDING MACHINES
- STEEL BENDING MACHINES
- FORK LIFTS TRUCKS
- SKID STEER LOADERS
- DUMPERS
- AGRICULTURAL AND FORESTRY MACHINES
- MUNICIPAL VEHICLES
- AIRPORT MACHINERY

PRODUCT FEATURES:

- ✓ High volumetric and mechanical efficiencies
- ✓ Very smooth running at low speeds
- ✓ High starting torque / constant torque
- ✓ Wide speed range
- ✓ Compact Design
- ✓ Low maintenance and high reliability
- ✓ Bi-directional
- ✓ High radial and axial force allowed
- ✓ Speed sensor available
- ✓ Built-in valves available

MOTOR TECHNICAL DATA

Motor	Size	Displacement	Theoretical torque	Max cont. pressure	Max cont. speed	Peak speed (**)	Max cont. power (*)	Max power	Dry weight
		[cc]	[Nm/bar]	[bar]	[rpm]	[rpm]	[kW]	[kW]	[kg]
R8D 300	H2	314	5	270	900	1100	45	66	42
R8D 350	H3	342	5.4	270	850	950	85	130	68
R8D 400	H3	398	6.3	270	750	860	85	130	68
R8D 450	H3	452	7.2	270	650	760	85	130	68
R8D 500	H3	492	7.8	270	600	690	85	130	68
R8D 600	H3	594	9.5	270	500	570	85	130	68
R8D 700	H3	707	11.2	170	440	500	78	118	68
R8D 500	H4	493	7.8	270	700	800	130	160	92
R8D 600	H4	584	9.3	270	700	800	130	160	92
R8D 700	H4	714	11.4	270	500	580	130	160	92
R8D 800	H4	792	12.6	270	450	530	130	160	92
R8D 850	H4	847	13.5	270	420	490	130	160	92
R8D 900	H4	904	14.4	270	400	460	130	160	92
R8D 1000	H4	992	15.8	270	355	405	130	160	92
R8D 1250	H4	1247	19.8	200	280	320	102	130	92
R8D 1100	H45	1182	18.8	250	400	450	158	190	120
R8D 1400	H45	1376	21.9	250	350	400	158	190	120
R8D 900	H5	941	15	270	550	600	178	210	173
R8D 1000	H5	1094	17.4	270	500	550	178	210	173
R8D 1200	H5	1231	19.6	270	450	510	178	210	173
R8D 1400	H5	1376	21.9	270	410	470	178	210	173
R8D 1500	H5	1528	24.3	270	390	450	178	210	173
R8D 1600	H5	1648	26.2	270	370	425	178	210	173
R8D 1800	H5	1815	28.9	250	340	390	178	210	173
R8D 2000	H5	2034	32.4	190	280	310	140	160	173
R8D 1800	H55	1800	28.7	270	265	290	190	220	203
R8D 2000	H55	1962	31.2	270	245	270	190	220	203
R8D 2100	H55	2035	32.4	270	235	260	190	220	203
R8D 2150	H55	2126	33.8	270	235	260	190	220	203
R8D 2200	H55	2193	34.9	270	220	240	190	220	203
R8D 2300	H55	2293	36.5	250	210	235	180	210	203
R8D 2400	H55	2393	38.1	250	190	220	170	210	203
R8D 1800	H6	1866	29.7	270	350	400	220	245	308
R8D 2000	H6	1993	31.7	270	350	400	220	245	308
R8D 2200	H6	2206	35.1	270	325	375	220	245	308
R8D 2500	H6	2525	40.2	270	285	325	220	245	308
R8D 2800	H6	2807	44.7	270	250	290	220	245	308
R8D 3000	H6	2983	47.5	270	235	270	220	245	308
R8D 3200	H6	3289	52.4	270	210	240	220	245	308
R8D 3500	H6	3479	55.4	270	200	230	210	235	308

Motor	Size	Displacement [cc]	Theoretical torque [Nm/bar]	Max cont. pressure [bar]	Max cont. speed [rpm]	Peak speed (**) [rpm]	Max cont. power (*) [kW]	Max power [kW]	Dry weight [kg]
R8D 3400	H7	3413	54.3	270	200	220	238	265	405
R8D 3600	H7	3650	58.1	270	185	210	238	265	405
R8D 3900	H7	3907	62.2	270	175	200	238	265	405
R8D 4300	H7	4343	69.1	270	160	190	238	265	405
R8D 4600	H7	4616	73.5	270	150	190	238	265	405
R8D 5000	H7	5088	81.0	270	140	180	238	265	405
R8D 5400	H7	5384	85.7	270	130	170	230	258	405
R8D 3000	H8	3020	48.1	270	240	300	215	236	590
R8D 6000	H8	5966	95	250	120	140	215	236	590
R8D 6500	H8	6581	104.7	250	120	140	215	236	590
R8D 6800	H8	6962	110.8	250	120	140	215	236	590
R8D 7600	H8	7620	121.3	250	90	100	215	236	590
R8D 8000	H8	8062	128.3	240	80	90	215	236	590
R8D 7000	H9	7050	112	270	160	190	330	370	750
R8D 8000	H9	8332	132.6	270	135	160	330	370	750
R8D 9000	H9	8757	139.4	260	130	155	330	370	750
R8D 10000	H9	10214	162.6	250	110	135	330	370	750
R8D 11000	H9	11016	175.3	250	105	120	330	370	750
R8D 12000	H9	12073	192.2	250	95	110	330	370	750
R8D 13000	H9	13020	207.3	250	90	105	330	370	750

For all motors:

- Hydrostatic test pressure: 420 bar

- Refer to motor performance diagrams for more information

- (*) For motor operation with a continuous duty cycle at maximum continuous power the flushing is usually required.

For more information please contact our technical department.

- (**) Do not exceed maximum power.

INTERCHANGEABILITY CHART

Italgrou motor code	Cross reference motor code
R8D 450/B30	HMB 30
R8D 800/B45	HMB 45
R8D 1000 H5 - R8D 1000/B60 H5	HMB 60
R8D 1400 H5 - R8D 1400/B80 H5	HMB 80
R8D 1600 H5 - R8D 1600/B100 H5	HMB 100
R8D 2150 H55	HMB 125
R8D 2200 H6 - R8D 2200/B125 H6	HMB 125
R8D 2500 H6 - R8D 2500/B150 H6	HMB 150
R8D 3000 H6 - R8D 3000/B200 H6	HMB 200
R8D 4600 H7	HMB 270
R8D 5400 H7	HMB 325
R8D 350-450-500/C H3	MR 350 - MR 450 - MRE 500
R8D 600-700-800/C H4	MR 600 - MR 700 - MRE 800
R8D 1100-1400/C H45	MR 1100 - MRE 1400
R8D 1000-1400-1600/C1100 H5	MR 1100 - MRE 1400 - MR 1600
R8D 1600-1800-2000/C H5	MR 1600 - MR 1800 - MRE 2100
R8D 1800-2100-2400/MR1800 H55	MR 1800 - MRE 2100 - MRA 2400
R8D 2500-2800-3000-3500/C H6	MR 2400 - MR 2800 - MRE 3100 MRA 3500
R8D 3600-4500-5400/C H7	MR 3600 - MR 4500 - MRE 5400
R8D 6500-6800-8000/C H8	MR 6500 - MR 7000 - MRE 8200
R8D 450-500/RM H3	RM 450 - RM 500
R8D 900/RM H5	RM 900
R8D 5000/RM H7	RM 5000
R8D H2/GM2	GM2
R8D H4/GM4	GM4
R8D H5/GM5	GM5
R8D H6/GM6	GM6
R8D H2/S	M2
R8D H3/S	M3
R8D H4/S	M4

R8D - ORDERING CODE

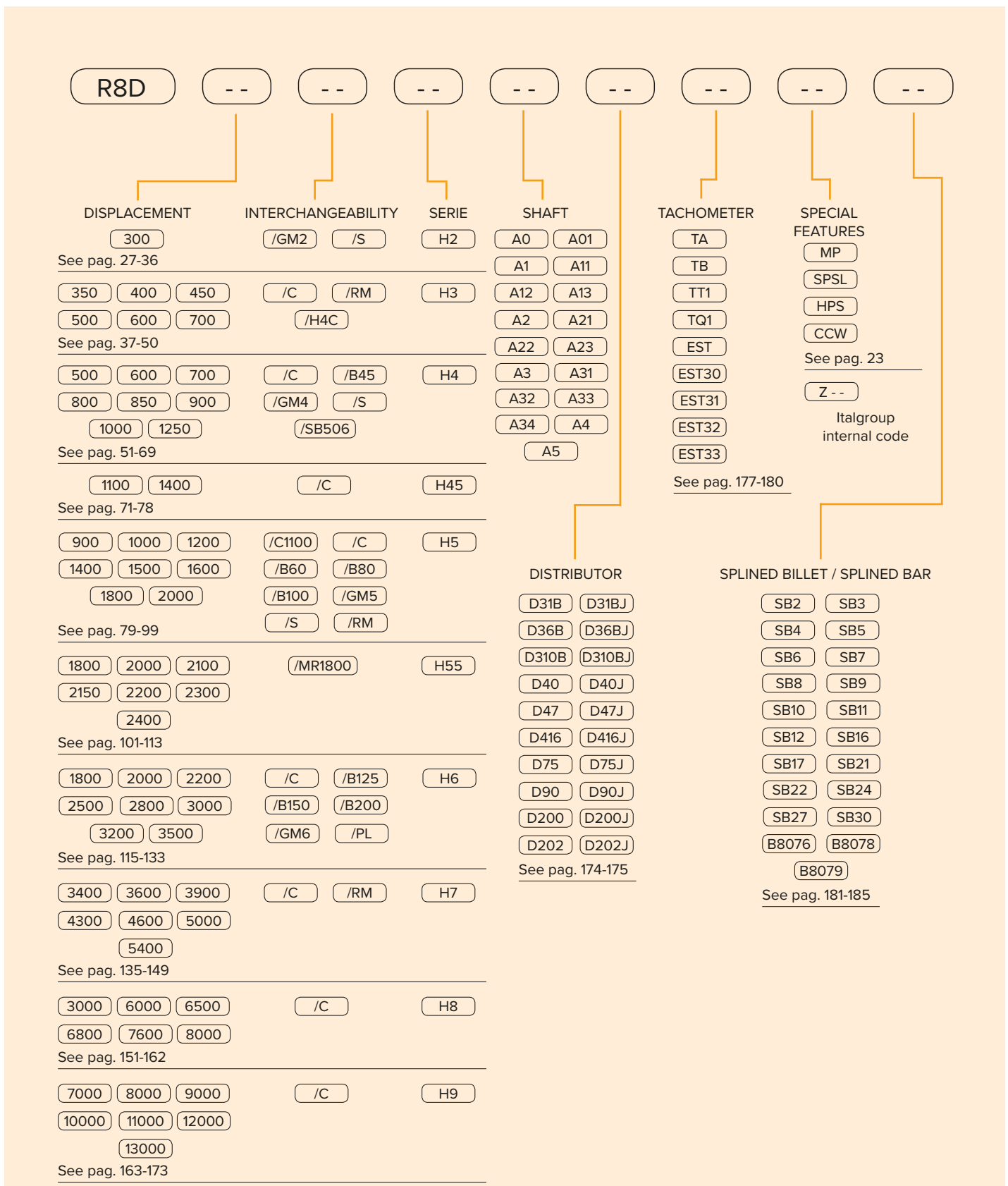

HYDRAULIC FLUID RECOMMENDATIONS

Fluid selection

In general, we recommend the use of hydraulic oils with minimum viscosity index of 95, with anti-wear additives (ISO HM and HV). Once normal working temperature is reached, the drain oil viscosity must be at least 35-40 cSt, preferably in the range from 40 to 60 cSt.

HE oils (ecological fluids) are allowed, but must be used with particular attention, because they can influence the motor seals compatibility, and can reduce motor performances and life. Please contact us in case of HE oils usage.

Optimal viscosity selection

Referring the first approximated selection to the room temperature, we advice the following:

Room temperature	Oil
-20°C/0°C	BP ENERGOL HLP – HM 22
-15°C/+5°C	BP ENERGOL HLP – HM 32
-8°C/+15°C	BP ENERGOL HLP – HM 46
0°C/+22°C	BP ENERGOL HLP – HM 68
+8°C/+30°C	BP ENERGOL HLP – HM 100
-20°C/+5°C	BP BARTRAN HV 32
-15°C/+22°C	BP BARTRAN HV 46
0°C/+30°C	BP BARTRAN HV 68

ATF (automatic transmission fluid) oils, SAE 10-20-30 W oils, multigrade motor oils (SAE 15 W 40, 10 W 40), universal oils, can also be used. Always fill the motor (please refer to the “DRAIN RECOMMENDATIONS” section) with the selected hydraulic fluid before motor start-up. During cold start-up avoid high-speed operation until the system reach the working temperature, in order to provide an adequate lubrication. Every 5-8 °C of increase respect to the optimal working temperature for the selected oil, the hydraulic fluid life decrease of about 40-50% (refer to “OXIDATION” section). Consequently, the motor lifetime will be affected by the working temperature increase respect to the optimal working temperature of the selected oil. The maximum continuous working temperature is 70 °C, the temperature must be measured from motor drain line. If the motor doesn't have a drain line, the temperature must be evaluated at the return line port.

Fire resistant oil limitations

	Max cont. Pressure [bar]	Max int. Pressure [bar]	Max Speed [rpm]
HFA, 5-95% oil-water	103	138	50%
HFB, 60-40% oil-water	138	172	100%
HFC, water-glycol	103	138	50%
HFD, ester phosphate	250	293	100%

Filtration

Hydraulic systems oil must always be filtered.

The choice of filtration grade derives from needs of service life and money spent. In order to obtain stated service life it is important to follow our recommendations concerning filtration grade.

When choosing the filter it is important to consider the amount of dirt particles that filter can absorb and still operate satisfactorily. For that reason we recommend filters showing when you need to substitute filtering cartridge.

- 25 µm filtration required in most applications
- 10 µm filtration in closed circuit applications

Oxidation

Hydraulic oil oxidizes with time of use and temperature. Oxidation causes changes in colour and smell, acidity increase or sludge formation in the tank. Oxidation rate increases rapidly at surface temperatures above 60°C, in these situations oil should be checked more often.

The oxidation process increases the acidity of the fluid; the acidity is stated in terms of the “neutralization number”. Oxidation is usually slow at the beginning and then it increases rapidly.

A sharp increase (by a factor of 2 to 3) in neutralization number between inspections shows that oil has oxidized too much and should be replaced immediately.

Water content

Oil contamination by water can be detected by sampling from the bottom of the tank. Most hydraulic oils repel the water, which then collects at the bottom of the tank. This water must be drained off at regular intervals. Certain types of transmission oils and engine oils emulsify the water; this can be detected by coatings on filter cartridges or a change in the colour of the oil. In such cases, obtain your oil supplier advice.

Degree of contamination

Heavy contamination of the oil causes wear rising in hydraulic system components. Contamination causes must be immediately investigated and remedied.

Analysis

It is recommended oil being analyzed every 6 months. The analysis should cover viscosity, oxidation, water content, additives and contamination. Most oil suppliers are equipped to analyze oil state and to recommend appropriate action. Oil must be immediately replaced if the analysis shows that it is exhausted.

DRAIN RECOMMENDATIONS

MOTOR AXIS HORIZONTAL

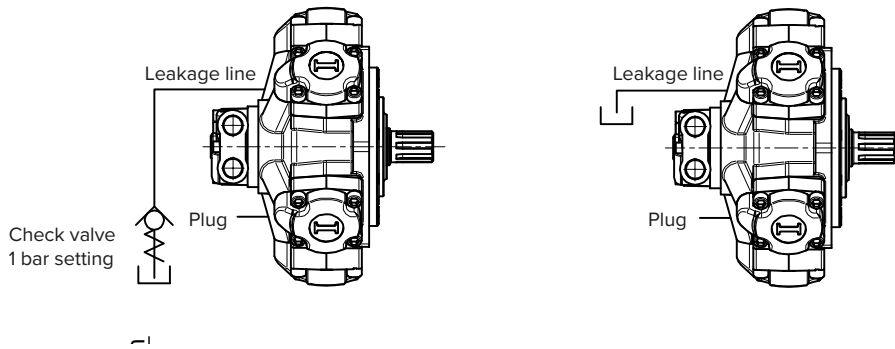

MOTOR AXIS VERTICAL, SHAFT DOWN

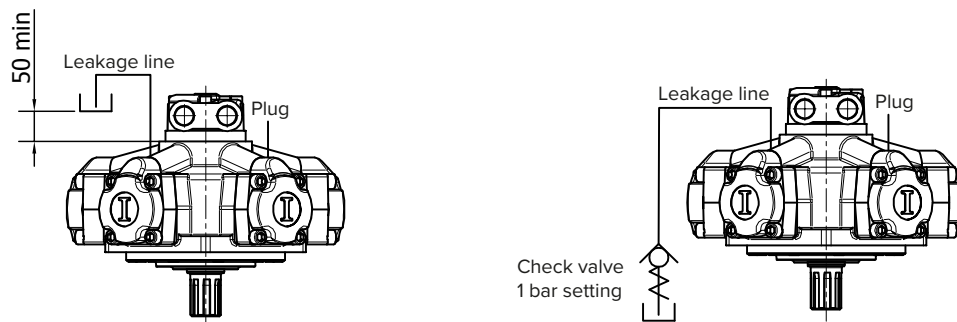

MOTOR AXIS VERTICAL, SHAFT UP

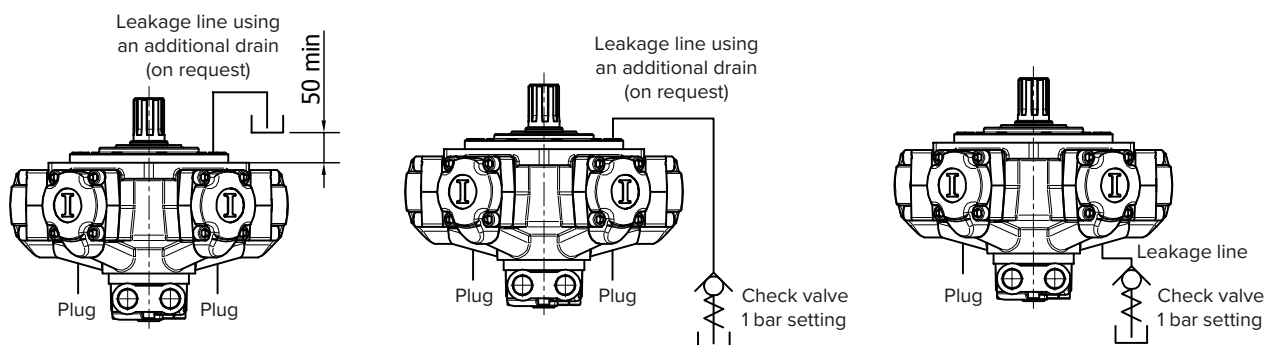

LEAKAGE LINE CONNECTION

Always fill the motor with hydraulic fluid before start-up. Arrange piping in a way that the motor cannot drain off and cannot generate air bubbles into the motor case. Under certain conditions it may be necessary to arrange a check valve in order to help avoid the motor draining off. Always check carefully that the leakage line pressure doesn't overcome 10 bar pressure: therefore leakage lines must be shorter as possible and with a minimum flow resistance.

FLUSHING

Motor	Flushing flow [l/min]
R8D H2	5
R8D H3	8
R8D H4	10
R8D H45 - R8D H5	15
R8D H55 - R8D H6 - R8D H7 - R8D H8 - R8D H9	20

Important note: the above value are approximated. The correct way to operate is the following: the flushing flow is adequate if during the motor operation the drain oil viscosity be at least 35-40 cSt, preferably in the range from 40 to 60 cSt.

Maximum continuous case pressure 6 bar (10 bar peak pressure). Special seals for 20-25 bar continuous case pressure are available upon request (ordering code: HPS).

FLUSHING OUTLET PORT

Please note: the flushing outlet port must always be located in the highest possible position.

MAXIMUM CASE PRESSURE

6 bar continuous
10 bar peak

For standard R8D motors

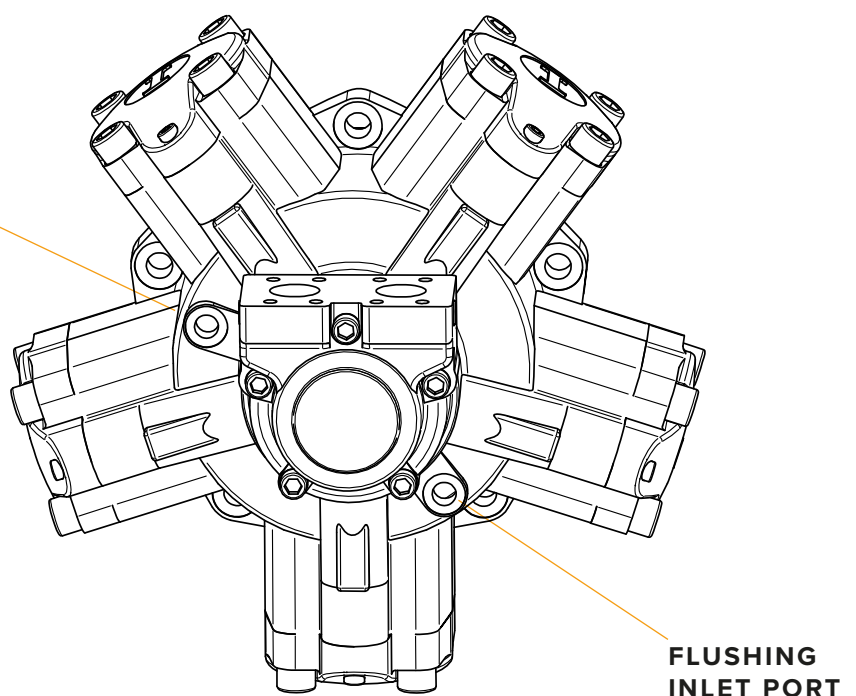

STANDARD SHAFT SEAL FEATURES

Features

Type: BABSL
 Form: AS DIN 3760
 Material: SIMRIT® 72 NBR 902
 SIMRIT® 75 FKM 595

Material

SIMMERRING® radial shaft seal with rubber covered O.D., short, flexibility suspended, spring loaded sealing lip and additional dust lip:
 see Part B/SIMMERRING®, sections 1.1 and 2.

Application

Sealing lip and O.D.:

- Acrylonitrile-butadiene rubber with 72 Shore A hardness (designation: SIMRIT® 72 NBR 902)
- Fluoro rubber with 75 Shore A hardness (designation: SIMRIT® 75 FKM 595)

Metal insert:

- Plain steel DIN 1624

Spring:

- Spring steel DIN 17223

Operating conditions

See Part B/ SIMMERRING®, sections 2. 4.

Media: mineral oils, synthetic oils

Temperature:

- 40°C to +100°C (SIMRIT® 72 NBR 902)
- 40°C to +160°C (SIMRIT® 75 FKM 595)

Surface speed: up to 5 m/s

Working pressure: see diagram on next page, pressure is function of surface speed (i.e. of rotating speed and shaft diameter)

Housing and machining criteria See Part B/ SIMMERRING®, sections 2.

Shaft:
 Tolerance: ISO h11
 Concentricity: IT 8
 Roughness: Ra=0.2-0.8 µm
 Rz=1-4 µm
 Rmax=6 µm
 Hardness: 45-60 HRc
 Roughness: non oriented;
 preferably by plunge grinding

Housing:
 Tolerance: ISO H8
 Roughness: Rmax<25 µm

Pressure diagram

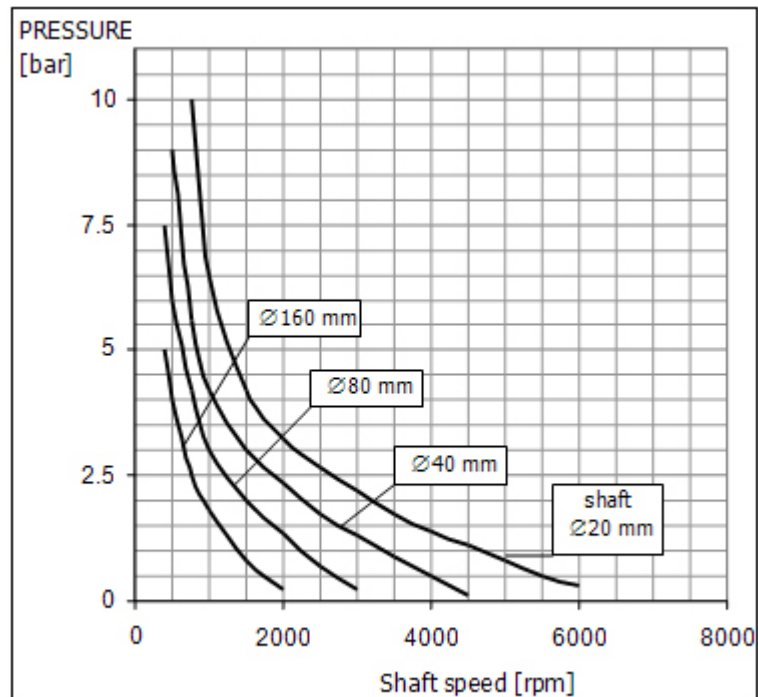

Diagram 1: Pressure Loading Limits

Special seals for 20-25 bar continuous case pressure are available upon request (ordering code: HPS). Refer to page 23 for more information.

MOTOR INSTALLATION AND STARTUP

Motor installation and start-up

The motor, after testing, it's packed in different ways that depends by customer and/or logistic requirements. The motor must be carefully moved from his box or pallet, with the assistance of correctly sized movimentation tools, like eyebolts (all the motors has a thread hole in the shaft end, please refer to the R8D general catalogue, shafts section) or lifting slings.

When the motor is moved from one place to another always be very careful and act in a way that the motor is stable and under control during movimentation (refer to handling and storage section for more details).

Before mount the motor, check carefully the absence of damage happened for example during transportation and/or storing.

For mounting dimensions please refer to the R8D installation drawings. The motor must be installed using the correct screws size (we recommends the use of 10.9 and 12.9 class resistance fixing screws) and must be placed on a structure that is capable to correctly support the motor during functioning: for this reason the structure must not only be able to support the motor weight but must also assure the absence of vibration during operation and must win the reaction forces that are generated by the working torque. Regarding the motor fitting design, the concentricity between the centering diameter (spigot) and shaft (both splined or parallel) must be assured with a strict tolerance (please refer to the following general indication). If the concentricity between the shaft and the centering diameter and/or fixing holes is not respected, in the worst case the motor can have an unusual failure or can work only with low performances. Splined adaptors (splined billets) are available upon request.

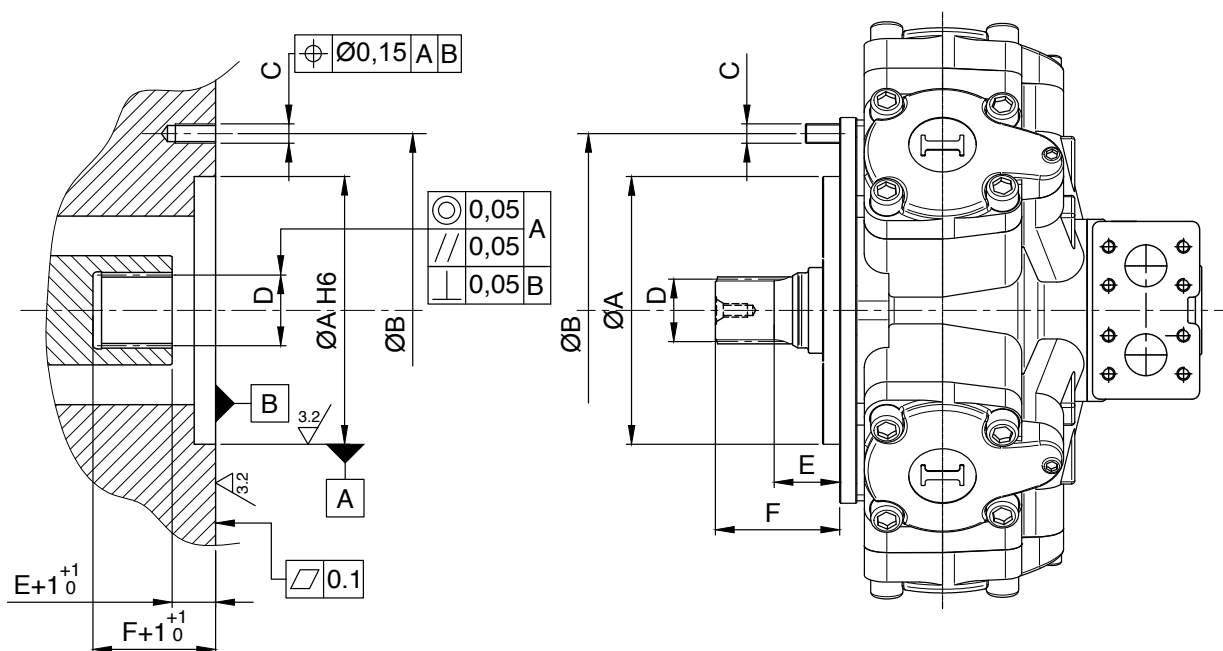

Hoses and piping must be clean and free from contamination. Use proper hoses for oil connection, both for inlet and outlet main ports, and for drain line. Refer to hoses and fitting constructors in order to correctly size and select hoses and fittings. In order to keep control on the oil compressibility keep hoses to the minimum recommended size and select pipelines most rigid as possible.

The motor can be mounted in any position (refer also to drain recommendations section). In run-away conditions you must use counterbalance valves. When the motor is installed vertically with shaft pointing upwards, consult our technical department. If the motor is connected to high inertial loads, the hydraulic system must be designed to prevent peaks of pressure and cavitation. Consider the use of relief valves, possibly directly mounted on motor distributor in case the application can generate pressure peaks at the motor ports: the relief valve should be able to discharge all the flow (or at least a good part of it) with a limited pressure increase. Italgroup can provide different valve types that can be placed directly on the motor distributor (please refer to Italgroup valves technical catalogue).

Motor case and pistons must be completely filled with oil before starting. Do not load motor to maximum working pressure instantly. During cold start-up avoid high-speed operation until the system reaches the working temperature. Connect the case drain directly to tank, and avoid excessive drain line pressure losses (the case drain pressure must not exceed 10 bar continuous pressure for R8D serie standard motors). The case drain port on the motor must be located on the highest point of the installation to ensure that the motor will always be full of oil. (See drain recommendations page for more details)

Maximum oil temperature must not exceed 70°C. Heat exchangers must be used with higher temperatures. The operating fluid viscosity must always be higher than a certain minimum value (see “fluid recommendation” section) in order to guarantee an optimal motor internal lubrication. When the working conditions cause the motor case overheating above a critical value, the motor flushing is required. Flushing consists in the introduction of fresh oil (taken from the hydraulic circuit) into the motor case. Oil must be taken from the return line to avoid internal motor damage (the continuous motor case pressure must be maximum 6 bar). Flushing is an important operation that can be very effective to improve motor lifetime with heavy duty working conditions and improve the motor mechanical efficiency.

The motor flushing, if the motor works in one direction only, can be easily performed connecting the motor return line to the lowest motor drain port. The highest motor drain port must be connected to the tank. For D75 and D90 flow distributors, the side 1/4” metallic plugs can be used for flushing circuit installation: in fact the plug (corresponding to the return line port) can be removed and the connection between motor low pressure port and motor case can be correctly realized.

MOTOR INSTALLATION AND STARTUP

If the motor axis is not horizontal and/or the motor works in bidirectional operation, please contact Italgroupt technical department, that can assist you to advice how to perform the desired operation in the best way. Just for your reference, Italgroupt can provide you flushing valves in order to perform an effective flushing circuit.

Minimum speed is very low and can reach values near to 0.5-1 rpm (depending on motor displacement). In case of low speed vibration a reasonable back pressure can eliminate or minimize the vibration and noise level (a general guideline value can be defined by 5-8 bar back pressure). For more information please contact our technical department.

Back pressure limit for R8D series motors is 70-80 bar (back pressure occurs for example when hydraulic motors are installed in series circuit). High back pressure values are often responsible of motor overheating, so if drain temperature reach values that bring the oil viscosity under the recommended limit (refer to fluid recommendations section), perform appropriate motor flushing and/or reduce the back pressure.

During start-up and in the period immediately after it, any hydraulic installation must be regularly and carefully checked at frequent intervals. The working pressure must be checked in order to understand that it agrees with the design values. The drain line pressure for standard motors must not overcome 10 bar continuous. If leakage occurs, check the reason, correct it and carry out new measurements. Check all lines, connections, screws, etc, and tighten if necessary. Replace contaminated fluid immediately.

The motor installation and start-up must be performed by instructed and experienced personnel only.

Please contact us freely to obtain further information.

MOTOR HANDLING AND STORAGE

Motor handling

The motor must be correctly packed during transport and correctly stored into the warehouse in order to avoid eventual damages that can make the motor functioning not adequate.

During handling operations, make sure that the motor shaft and tachometer shaft (if present) don't receive any hit, in order to avoid motor damage.

During all operations of lifting and handling, never movimentate motors by hand but use adequate tools. In order to avoid that motor can falls, creating danger for authorized working persons in the nearings, use one of following methods:

- use lifting slings of adequate capacity;
- use adequate eyebolt using the thread hole in the shaft end.

Refer to the following pictures.

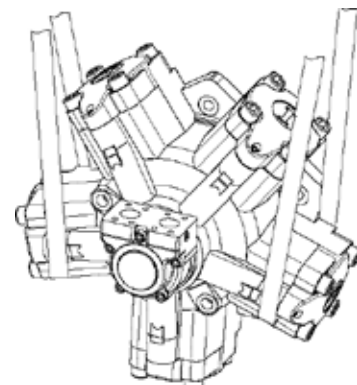
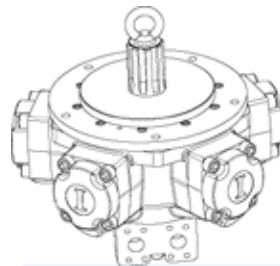

MOTOR HANDLING AND STORAGE

Storage

Storing must be carefully made using adequate storing tools (for example boxes, pallets, etc...) that can guarantee that the motor is stable and cannot move without control, in order to avoid damage problems. Make sure that the weight of the motor doesn't be substained by the motor shaft or by the tachometer shaft (if present).

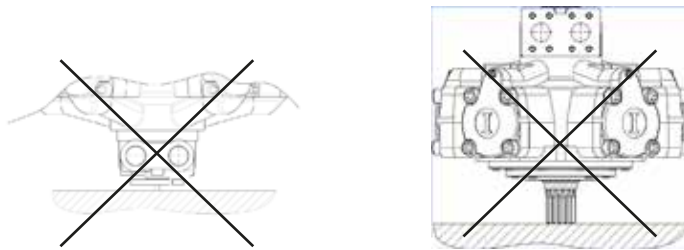

R8D series motors are supplied together with plastic plugs, that keep the hydraulic oil (that was used during final test in Italgrou testing workbench) inside the motor. A thin oil film is present on the internal motor parts, whereas the external parts are covered with antirust oil that prevents damage from oxidation and corrosion.

Therefore the motors can be safely stored into the customer warehouse without performance losses for long periods (up to 4-6 months).

The storing location must has some important characteristics:

- room temperature comprised between -15°C and $+55^{\circ}\text{C}$ without fast and/or excessives temperature excursions;
- low relative humidity;
- absence of aggressive and corrosive medias in the motor nearings.

In particular, if motor should be motionless for more than 4-6 months, it must be protected against internal rust. Proceed as follows:

- fill the motor case with hydraulic oil. After that the motor case is full of oil, close it with a screw plug;
- fill the motor also from inlet or outlet port. Turn the shaft by hand (the shaft must make about one revolution) and finally close the inlet and outlet ports.

Please note that the plastic plugs are necessary not only to keep the hydraulic oil inside the motor, but even to avoid that dirt and other fluids (like water for example) can enter into the motor and create damage during storing or during motor start-up. Therefore make sure all drain ports, supply ports and discharge ports are closed during motor handling and storing. If plugs are missing, use plastic plugs or adequate systems in order to guarantee that the motor is well protected by dirt and other fluids.

MAINTENANCE OPERATIONS

Maintenance operations All the assembly and maintenance works must be performed when the motor is stopped and not connected to any power source, in order to avoid an accidental start-up. In addition the pressure inside the motor must be set to zero (the motor must be depressurized) before to perform maintenance operations. The motor maintenance must be performed by instructed and experienced personnel only, following carefully Italgroupp advices and procedures.

R8D series motors are internally lubricated by the operating fluid, if the motors are used according to the technical data reported into the R8D catalogue, they need very limited maintenance operations. In order to achieve good performances, long bearings lifetime and safe working, the working fluid must be carefully selected in function of the operating parameters (a fundamental parameter is the ambient temperature range). In case of fire resistance fluid usage , some limitation on pressure and speed can be required. Refer to hydraulic fluid recommendations section for more information. If required please contact Italgroupp technical department for further information.

Motor parts	Material
Motor shaft, rollers, pins, screws, distributor bush, rotating distributor, distributor joint, pistons, connecting rod, ring for rod	Steel
Motor case, cylinders, motor flange, distributor body	Cast iron
Distributor disk, piston shoes	Bronze
Slippers	Charged PTFE, PTFE
O-Rings	Elastomer
Radial shaft seal rings	Elastomer / charged PTFE

INSTRUCTIONS AND ADVICES

Bearings

The bearing life depends by different factors, like bearing type, motor speed, working pressure, external loads, duty cycle, fluid viscosity, oil cleanliness, type and temperature.

Lifetime is measured by L_{10} which is called “theoretic lifetime”. It represents the number of cycles that 90% of identical bearings can effort at the same load without showing wear and tear.

Please refer to bearing lifetime diagrams reported in the following pages to obtain the theoretical bearing lifetime. **The lifetimes diagrams shown the L_{50} , median or average lifetime, that can be considered as 5 times L_{10} .**

Please note that the theoretical lifetime can be different from the real lifetime, especially in case of heavy duty applications with continuous work cycle.

Please contact ItalgrouP S.r.l. for more information.

Motor creep speed

The hydraulic motor is able to hold the load acting as a brake (if proper valves or circuit are considered and installed), but a certain creep speed is always present: this is typical of all brands hydraulic motors.

The motor creep speed depends by many factors, like operating conditions (motor displacement and type, pressure load on the shaft, oil viscosity, type and temperature)

If creep speed is higher than desired value a negative brake can be considered: ItalgrouP can supply negative brakes that can be fitted to the hydraulic motor.

Please contact ItalgrouP S.r.l. for more information.

SPECIAL FEATURES

Special features

Marine painting

If needed, special painting or primers are available in order to guarantee optimal protection against normal corrosion and marine environment corrosion. The ordering code is MP. Please contact Italgroup S.r.l. for more information.

Speedy-sleeve

A special inox sleeve is available upon request. In case the motor is used in aggressive medias or environments, this can be very useful in order to protect the motor shaft surface located in proximity of the motor shaft seal. This improves the shaft and seal endurance respect to wear and corrosion. The ordering code is SPSL. Please contact Italgroup S.r.l. for more information.

High pressure shaft seal

Standard R8D motors are supplied with high pressure shaft seals, the continuous drain pressure must be maximum 6 bar, whereas the peak drain pressure must be maximum 10 bar. In case the drain line can or must has a higher pressure, special shaft seals are available upon request. The ordering code is HPS. The drain pressure with HPS shaft seal can reach 20-25 bar continuous pressure and 30 bar peak pressure. The HPS shaft seal is bi-directional also, so it can be used for example in underwater applications. Please contact Italgroup S.r.l. for more information.

Counterclockwise rotation

Standard R8D motors are supplied with clockwise distributor timing. Please refer to the installation drawings of each section for more information. With ordering code CCW the motor is supplied with counterclockwise rotation timing. Contact Italgroup for more information.

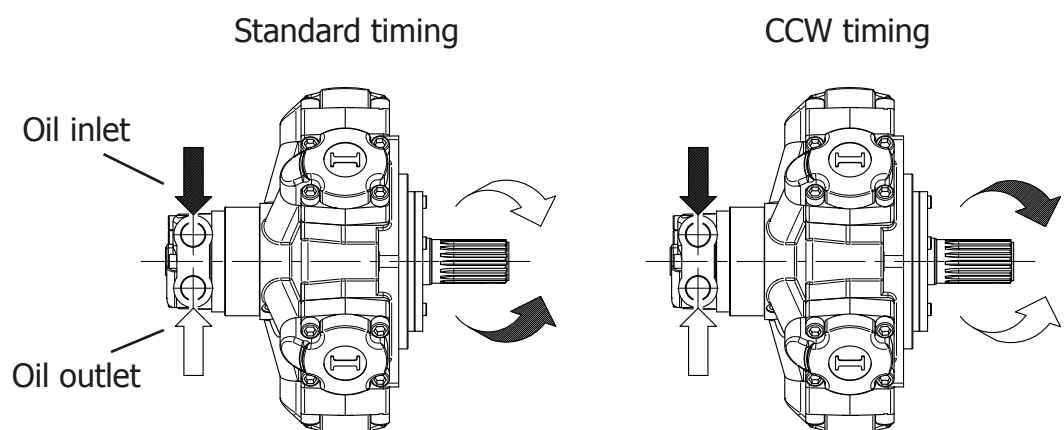

TROUBLESHOOTING

Problem	Possible cause	Solution
Excessive noises	Cavitation	Adopt an anti-cavitation system
	Mechanical vibrations	Check and fix damaged components
	Irregular pressure or flow	Check other components (pump, valves, accumulators) and check drain flow
	Air bubbles in the circuit	Bleed circuit
Unit overheating	Overflow	Check max allowed flow
	Overpressure	Check relief valve pressure setting
	Oil viscosity too low	Choose the appropriate oil according to the temperature
	Undersized cooling system	Improve cooling system
	Working without oil in the case	Overhaul the unit, fill with oil before start-up
Anomalous drainage flow	Worn motor internal components	Overhaul the motor
	Motor internal seals worn	Overhaul the motor
	Excessive pressure in the motor case	Check drain port size, pressure and flow, check piping connections
Insufficient torque	Pressure relief valve set incorrectly	Check relief valve pressure setting
	Undersized motor displacement	Replace with bigger displ. motor
	Pump not able to reach the design pressure	Check pump integrity
Insufficient speed	Oversized motor displacement	Replace with smaller displ. motor
	Pump not able to reach the design flow	Check pump integrity
	Undersized pump	Improve pump output flow
	Excessive drain flow	Overhaul the motor
Output shaft cannot rotate	Seized motor flow distributor	Overhaul the flow distributor
	Motor internal seizure	Overhaul the motor
	Motor internal seals worn	Check drain flow, overhaul the motor
	Air in the circuit	Bleed the circuit

Problem	Possible cause	Solution
Oil leakage	Worn seals	Replace seals
	Excessive pressure in the motor case	Check drain port size, pressure and flow, check piping connections
	Burst motor shaft seal	Check drain port size, pressure and flow, check piping connections
Incorrect sense of rotation	Pipes incorrectly connected	Check pipe connections
	Incorrect rotating distributor timing	Change rotating distributor timing

LENGHT	1 m	= 39,3701 in = 3,2808 ft = 1,0936 yd = 1000 mm	
	1 in	= 0,0833 ft = 25,4 mm	
	1 ft	= 0,3048 m = 0,3333 yd = 12 in	
	1 yd	= 0,9144 m = 3 ft = 36 in	
	1 km	= 1000 m = 1093,6 yd = 0,6214 mile	
	1 mile	= 1,609 km = 1760 yd	
	SPEED	1 m/s	= 3,6 km/h = 2,237 mph = 3,2808 ft/s
		1 km/h	= 0,2778 m/s = 0,6214 mph = 0,9113 ft/s
		1 mph	= 1,609 km/h = 0,447 m/s = 1,467 ft/s
		1 ft/s	= 0,3048 m/s = 1,0973 km/h = 0,6818 mph

MASS	1 kg	= 2,2046 lb	
	FORCE 1 N	= 0,102 kgf = 0,2248 lbf	
		1 kgf	= 2,205 lbf = 9,806 N
	1 lbf	= 0,4536 kgf = 4,448 N	
PRESSURE	1 bar	= 14,223 psi = 0,99 atm = 1,02 ata = 100000 Pa = 100 kPa = 0,1 MPa	
	1 psi	= 0,0703 bar	
	FLOW 1 l/min	= 0,264 gpm = 1000 cc/Rev	
		1 gpm	= 3,785 l/min = 3785 cc/min
		1 m ³ /s	= 60000 l/min = 15852 gpm

POWER 1 kW	= 1,341 HP = 1,3596 CV	
	1 HP	= 0,7457 kW = 1,0139 CV
VOLUME 1 m ³	= 1000 l	
	1 l	= 61,023 in ³ = 0,264 galUS
	1 in ³	= 0,01639 l = 16,39 cm ³ = 0,004326 galUS
	1 galUS	= 3,7879 l = 231,15 in ³
	TORQUE 1 Nm	= 0,102 kgm = 0,7376 lbf ft
1 kgm		= 9,806 Nm = 7,2325 lbf ft
	1 lbf ft	= 0,1383 kgm = 1,3558 Nm

R8D H2

R8D 300 H2	Pag. 28 - 29
R8D 300/GM2 H2	Pag. 30 - 31
R8D 300/S H2	Pag. 32 - 33
R8D H2 - PERFORMANCE CURVES	Pag. 34 - 35
R8D H2 - ORDERING CODE	Pag. 36

R8D 300 H2

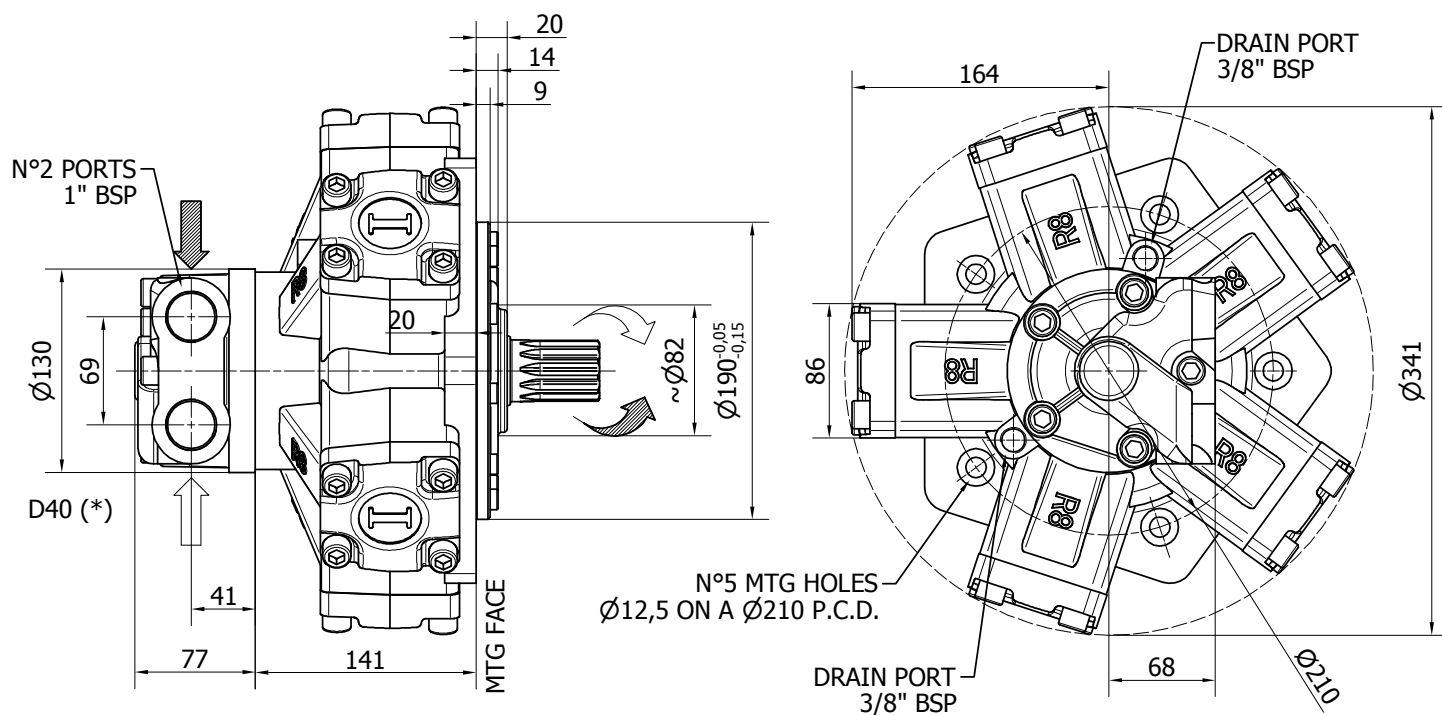

TECHNICAL DATA

		300
DISPLACEMENT	[cc]	314
SPECIFIC TORQUE	[Nm/bar]	5
MAX. CONT. PRESSURE	[bar]	270
HYDROSTATIC TEST PRESSURE	[bar]	420
MAX. CONT. SPEED	[rpm]	900
PEAK SPEED (**)	[rpm]	1100
MAX. CONT. POWER (***)	[kW]	45
MAX. POWER	[kW]	66
MAX. CASE PRESSURE	[bar]	6
DRY WEIGHT	[kg]	42
TEMPERATURE RANGE (**)	[°C]	-30÷70

- (*) The standard distributor (D40) is shown. Please refer to distributors section (pag. 174-175) for different distributor interfaces.

- (**) Please refer to the hydraulic fluid recommendations (pag. 10-11).

- (***) Do not exceed maximum power (see pag. 13).

- (****) For motor operation with a continuous duty cycle at maximum continuous power the flushing is usually required. For more information please contact our technical department.

SHAFTS

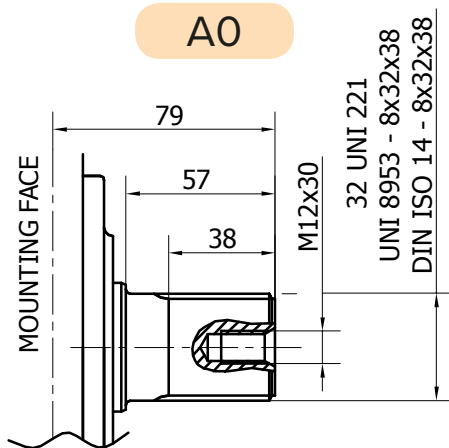

Available spline billet: SB2

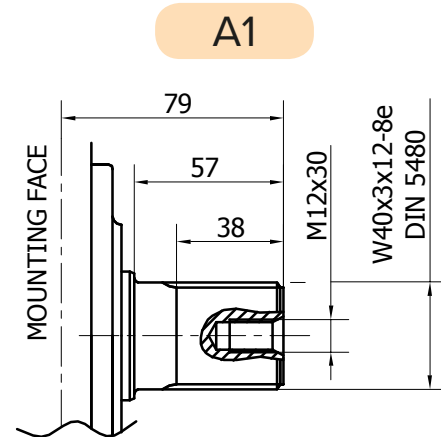

Available spline billet: SB22

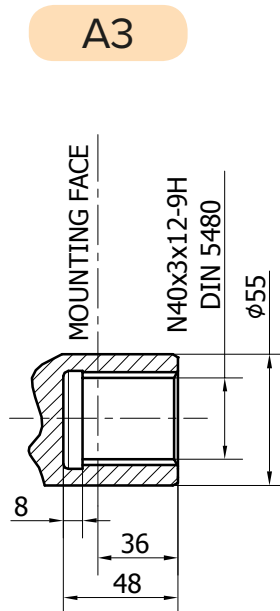
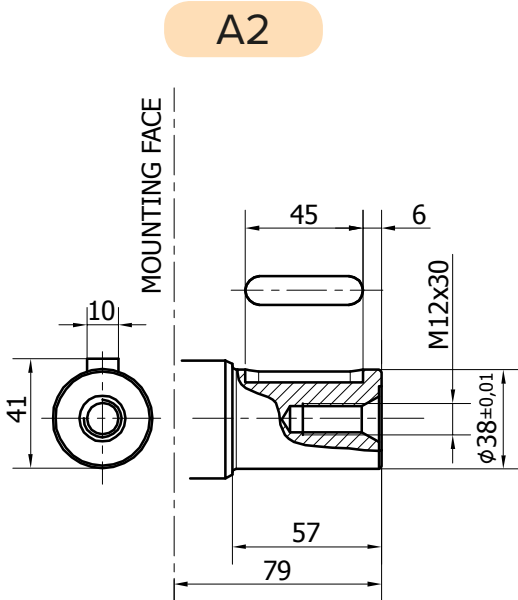

Available spline bar: B8076

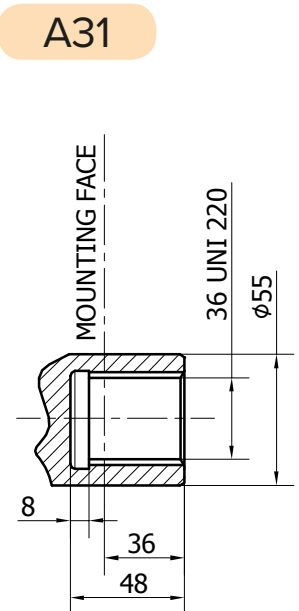

Available spline bar: B8078

R8D H2/GM2

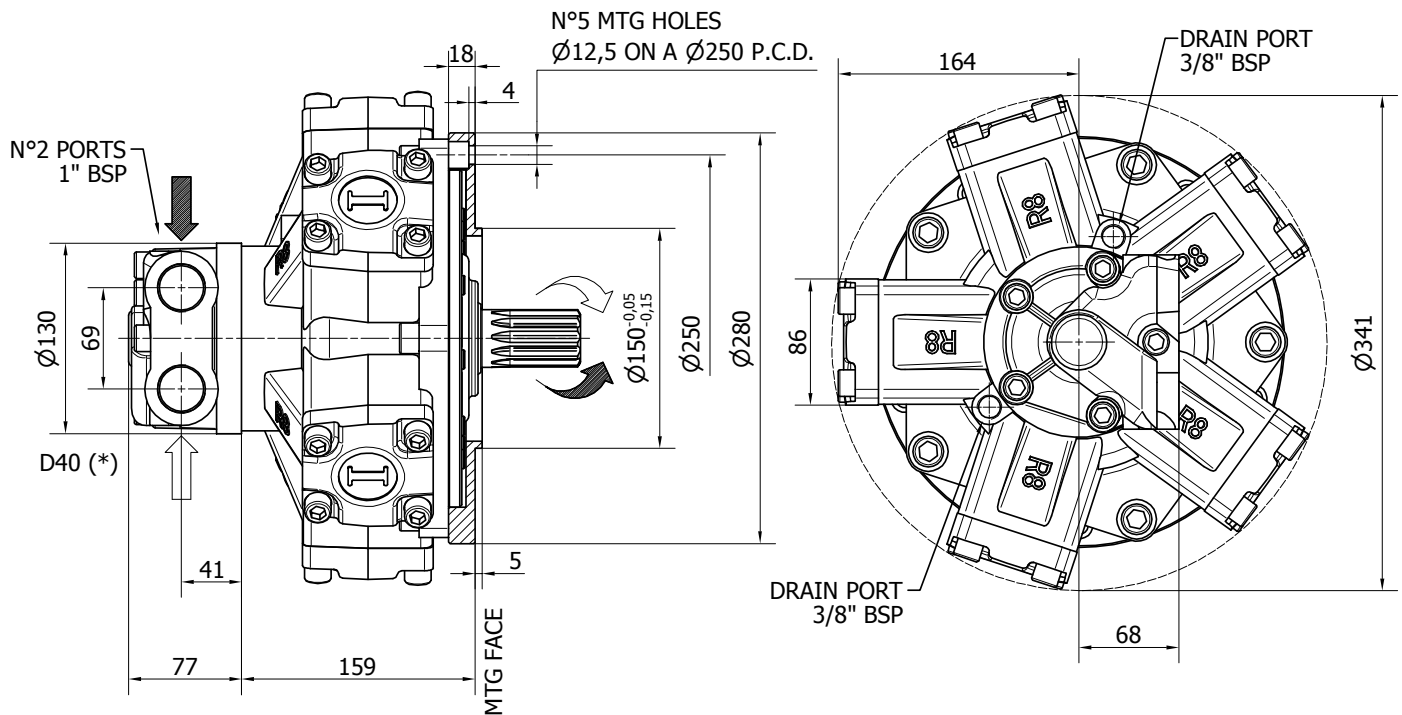

TECHNICAL DATA

		300
DISPLACEMENT	[cc]	314
SPECIFIC TORQUE	[Nm/bar]	5
MAX. CONT. PRESSURE	[bar]	270
HYDROSTATIC TEST PRESSURE	[bar]	420
MAX. CONT. SPEED	[rpm]	900
PEAK SPEED (**)	[rpm]	1100
MAX. CONT. POWER (***)	[kW]	45
MAX. POWER	[kW]	66
MAX. CASE PRESSURE	[bar]	6
DRY WEIGHT	[kg]	42
TEMPERATURE RANGE (**)	[°C]	-30÷70

- (*) The standard distributor (D40) is shown. Please refer to distributors section (pag. 174-175) for different distributor interfaces.

- (**) Please refer to the hydraulic fluid recommendations (pag. 10-11).

- (***) Do not exceed maximum power (see pag. 13).

- (****) For motor operation with a continuous duty cycle at maximum continuous power the flushing is usually required. For more information please contact our technical department.

SHAFTS

A0

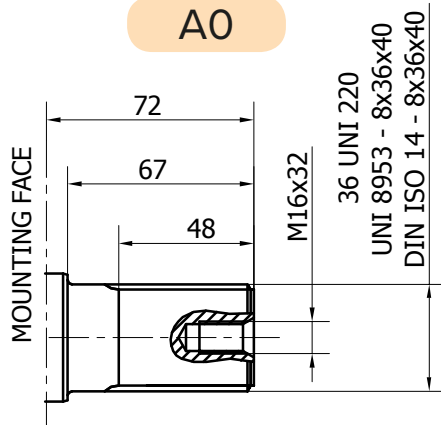

Available spline billet: SB3

A1

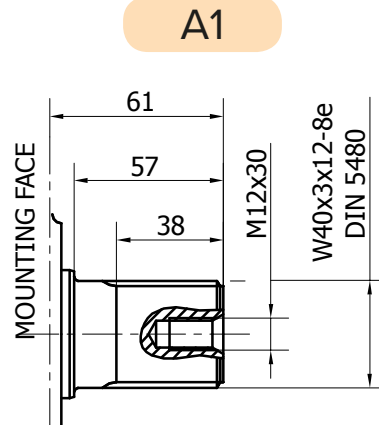

Available spline billet: SB22

A2

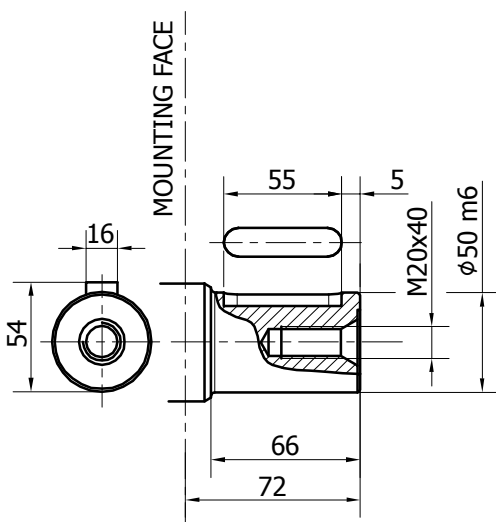

A3

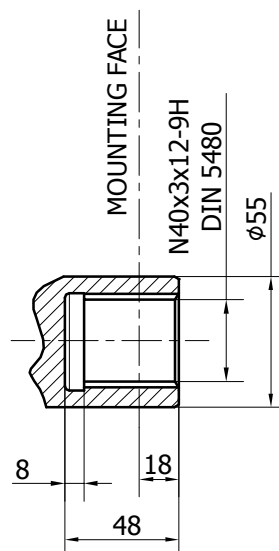

Available spline bar: B8076

A31

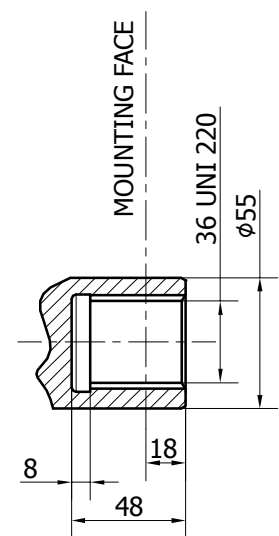

Available spline bar: B8078

R8D H2/S

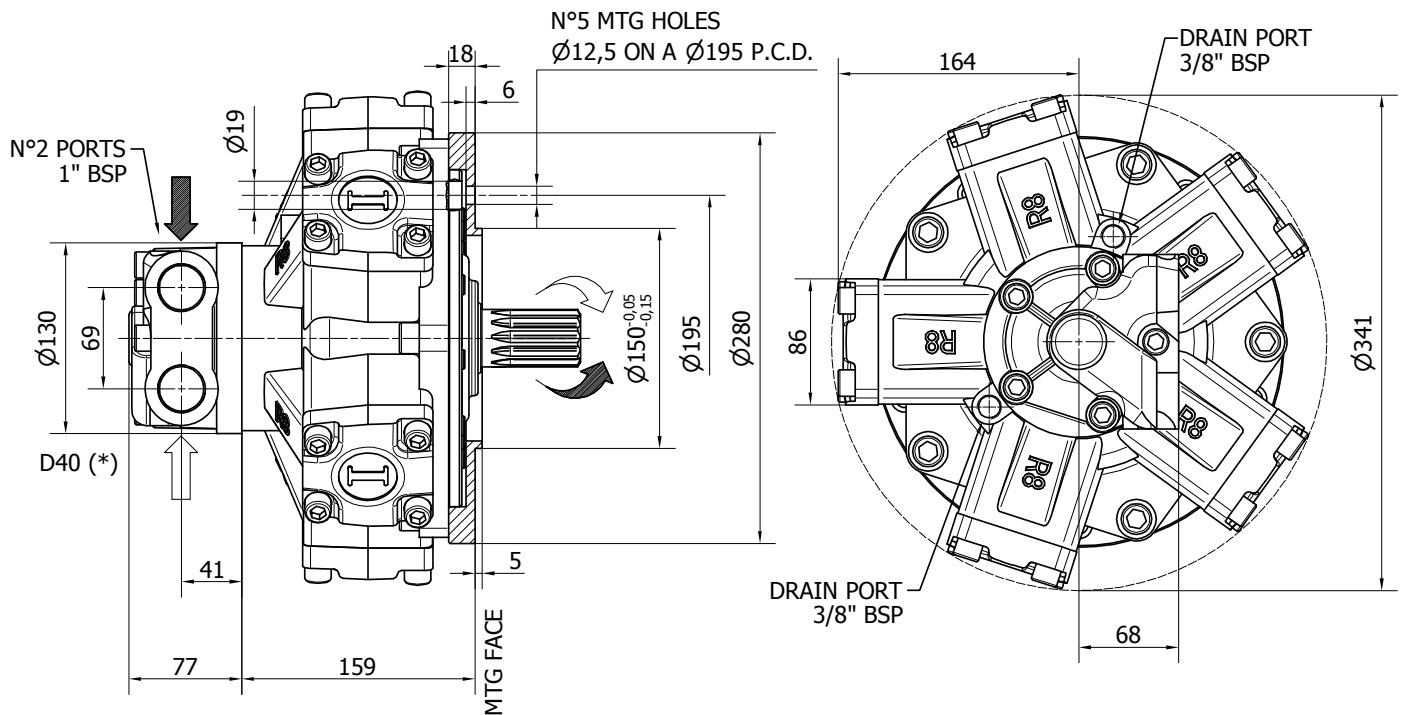

TECHNICAL DATA

		300
DISPLACEMENT	[cc]	314
SPECIFIC TORQUE	[Nm/bar]	5
MAX. CONT. PRESSURE	[bar]	270
HYDROSTATIC TEST PRESSURE	[bar]	420
MAX. CONT. SPEED	[rpm]	900
PEAK SPEED (***)	[rpm]	1100
MAX. CONT. POWER (****)	[kW]	45
MAX. POWER	[kW]	66
MAX. CASE PRESSURE	[bar]	6
DRY WEIGHT	[kg]	42
TEMPERATURE RANGE (**)	[°C]	-30÷70

- (*) The standard distributor (D40) is shown. Please refer to distributors section (pag. 174-175) for different distributor interfaces.

- (**) Please refer to the hydraulic fluid recommendations (pag. 10-11).

- (***) Do not exceed maximum power (see pag. 13).

- (****) For motor operation with a continuous duty cycle at maximum continuous power the flushing is usually required. For more information please contact our technical department.

SHAFTS

A0

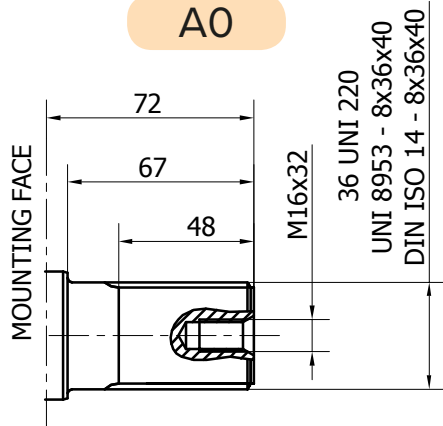

Available spline billet: **SB3**

A1

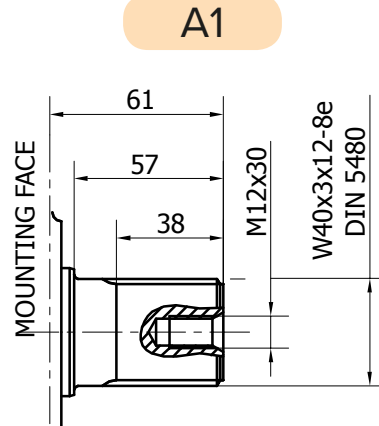

Available spline billet: **SB22**

A2

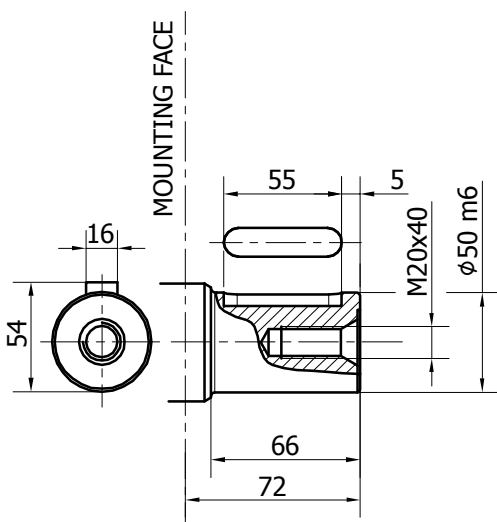

A3

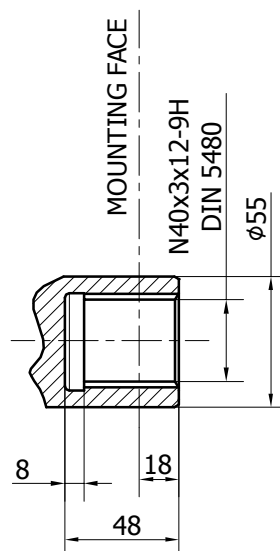

Available spline bar: **B8076**

A31

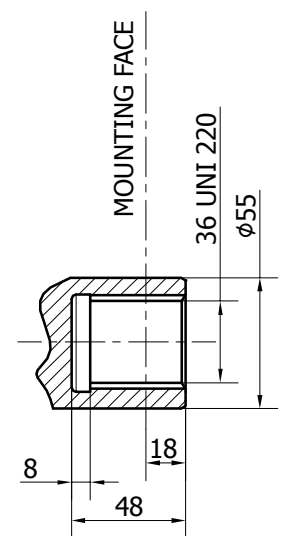

Available spline bar: **B8078**

R8D H2 - PERFORMANCE CURVES

R8D 300 H2

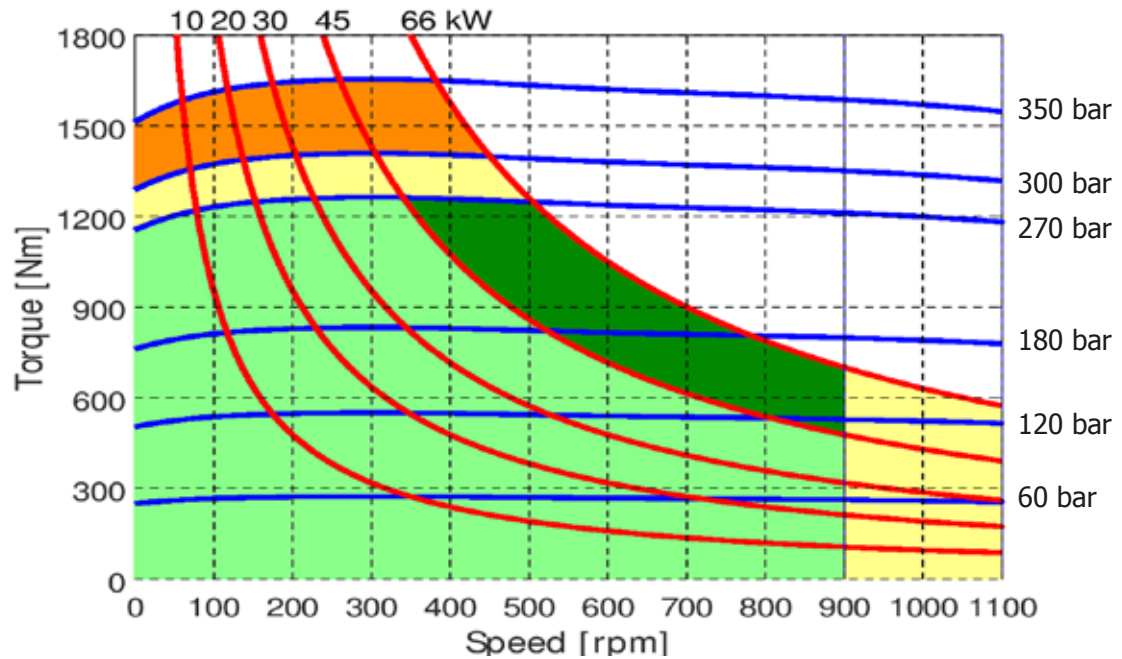

- Continuous operation
- Continuous operation with flushing or intermittent operation (see below for intermittent operation)
- Intermittent operation: permitted for a 15% of duty cycle, for 3 minutes maximum period
- Peak operation: permitted for very short periods (3-5 seconds every 10-15 minutes)

The above diagrams are referring to the hydraulic motor working with a fluid in ideal conditions (viscosity at 40 cSt). In case the working temperature increases and viscosity reach values under the recommended values (see hydraulic fluid recommendations) flushing must be performed or ISO oil grade must be changed. The working temperature must not overcome 70 °C.

CREEP SPEED - VOLUMETRIC EFFICIENCY

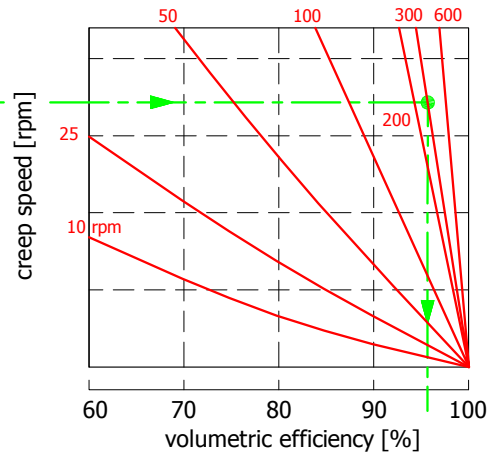
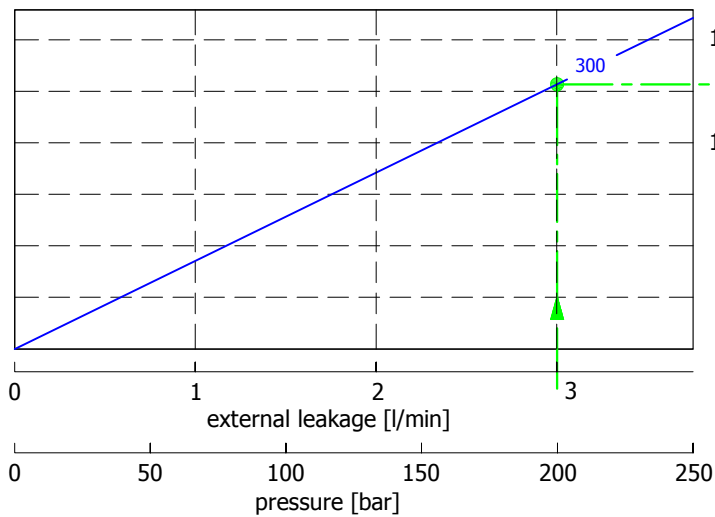

Reference viscosity: 40 cSt

Example:

We suppose (300 cc): $p=200$ [bar], we obtain: external leakage 2,9 [l/min], shaft creep speed 12,7 [rpm].
 If we suppose (300 cc): $p=200$ [bar] and $n=300$ [rpm] we obtain a volumetric efficiency of 96%;

BEARING LIFE

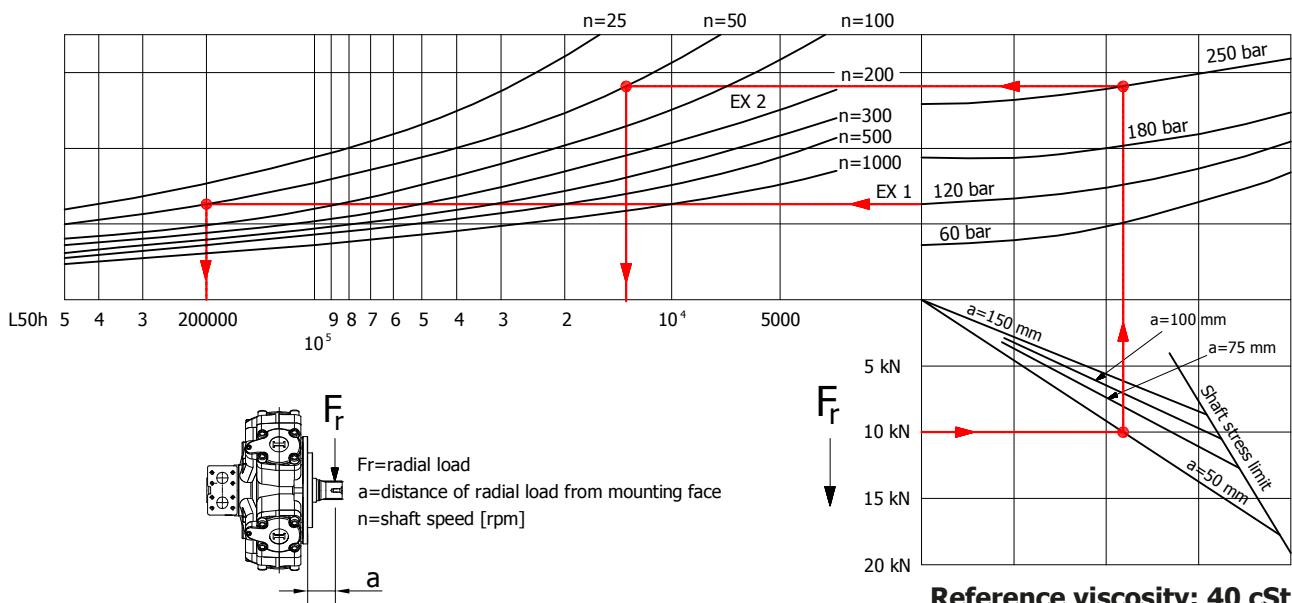

Reference viscosity: 40 cSt

Example:

We suppose (EX1): $p=120$ [bar], $n=50$ [rpm]; we obtain an average lifetime of 200000 [h].
 If we suppose (EX2): $F_r=10$ [kN], $a=50$ [mm], $n=50$ [rpm] and $p=250$ [bar] we obtain an average lifetime of 12500 [h].

R8D H2 - ORDERING CODE

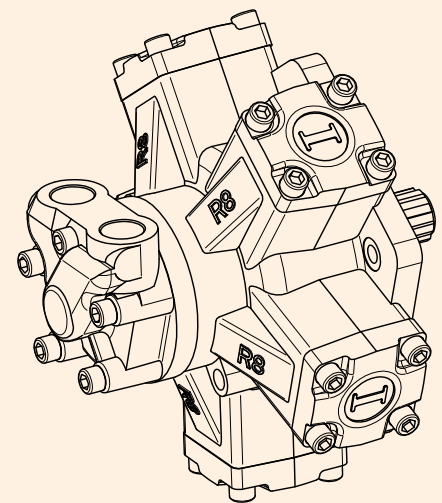
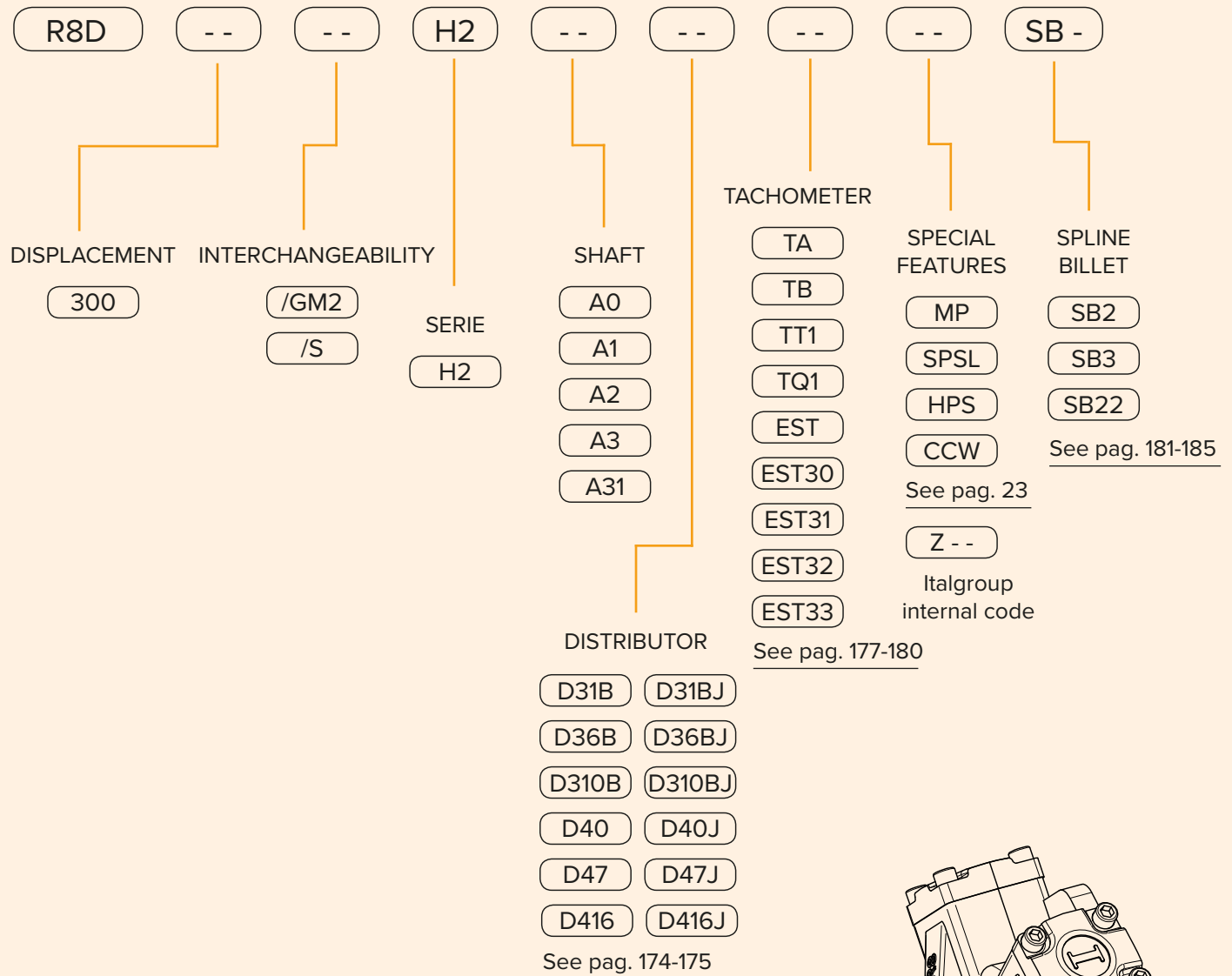

EXAMPLES:

- R8D 300/GM2 H2 A1 D40
- R8D 300 H2 A2 D310B
- R8D 300/GM2 H2 A0 D47 CCW

R8D H3

R8D H3	Pag. 38 - 39
R8D H3/C	Pag. 40 - 41
R8D H3/RM	Pag. 42 - 43
R8D H3/H4C	Pag. 44 - 45
R8D H3 - PERFORMANCE CURVES	Pag. 46 - 49
R8D H3 - ORDERING CODE	Pag. 50

R8D H3

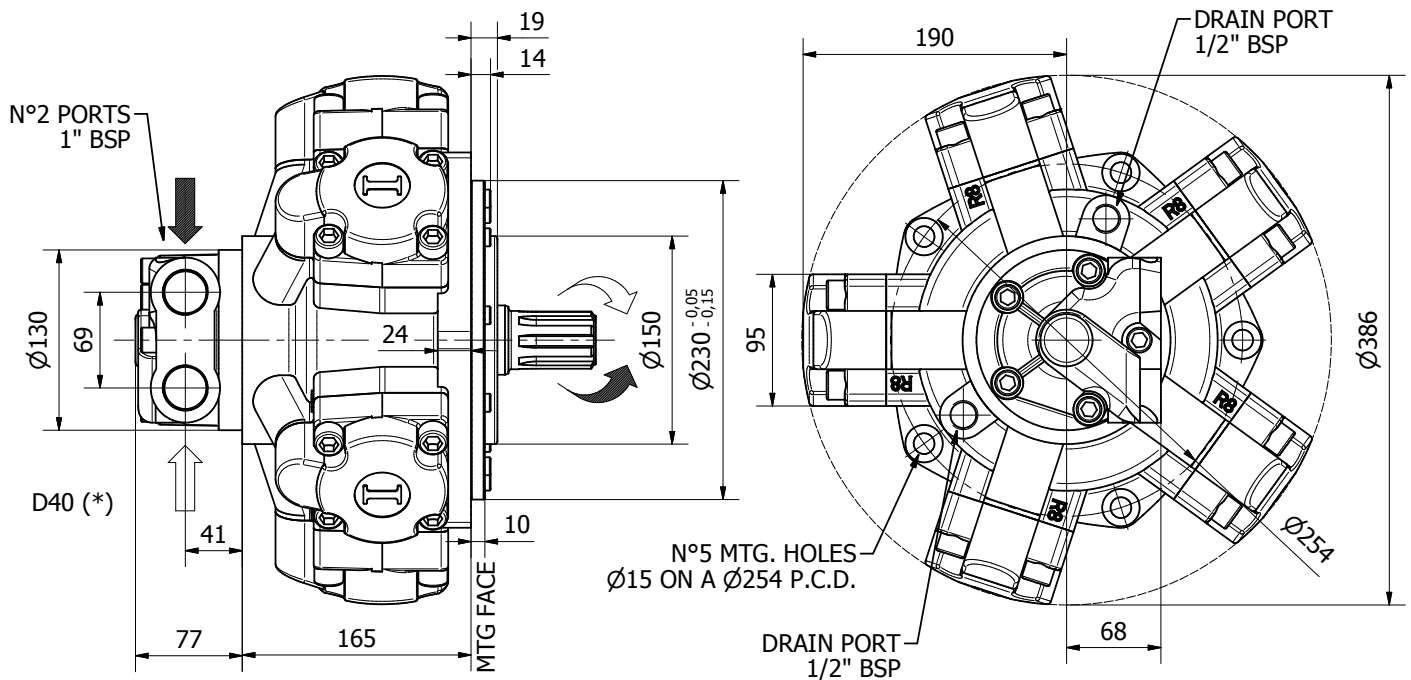

TECHNICAL DATA

		350	400	450	500	600	700
DISPLACEMENT	[cc]	342	398	452	492	594	707
SPECIFIC TORQUE	[Nm/bar]	5.4	6.3	7.2	7.8	9.5	11.2
MAX. CONT. PRESSURE	[bar]	270	270	270	270	270	170
HYDROSTATIC TEST PRESSURE	[bar]	420	420	420	420	420	420
MAX. CONT. SPEED	[rpm]	850	750	650	600	500	440
PEAK SPEED (***)	[rpm]	950	860	760	690	570	500
MAX. CONT. POWER (****)	[kW]	85	85	85	85	85	78
MAX. POWER	[kW]	130	130	130	130	130	118
MAX. CASE PRESSURE	[bar]	6	6	6	6	6	6
DRY WEIGHT	[kg]	68	68	68	68	68	68
TEMPERATURE RANGE (**)	[°C]	-30÷70	-30÷70	-30÷70	-30÷70	-30÷70	-30÷70

- (*) The standard distributor (D40) is shown. Please refer to distributors section (pag. 174-175) for different distributor interfaces.

- (**) Please refer to the hydraulic fluid recommendations (pag. 10-11).

- (***) Do not exceed maximum power (see pag. 13).

- (****) For motor operation with a continuous duty cycle at maximum continuous power the flushing is usually required. For more information please contact our technical department.

SHAFTS

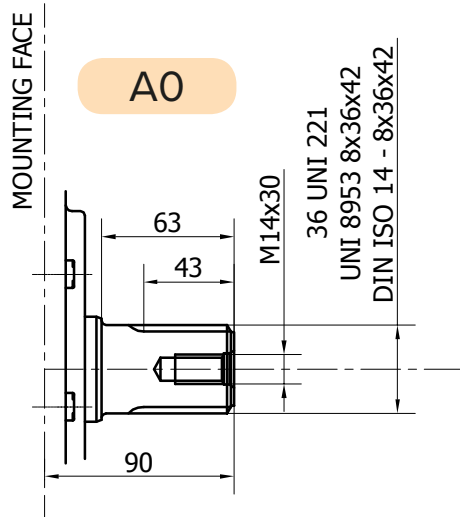

A0

36 UNI 221
UNI 8953 8x36x42
DIN ISO 14 - 8x36x42

Available spline billet: SB3

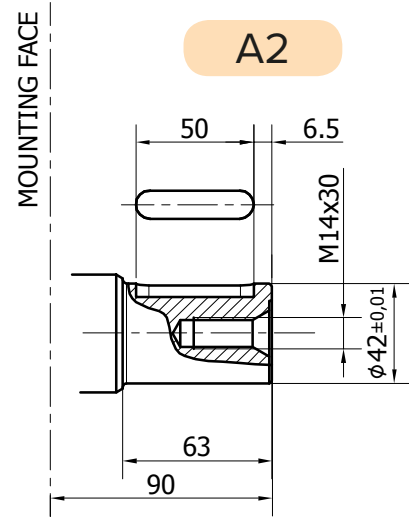

A2

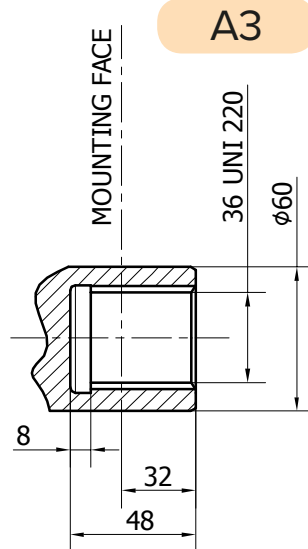

A3

36 UNI 220
 $\phi 60$

Available spline bar: B8078

R8D H3/C

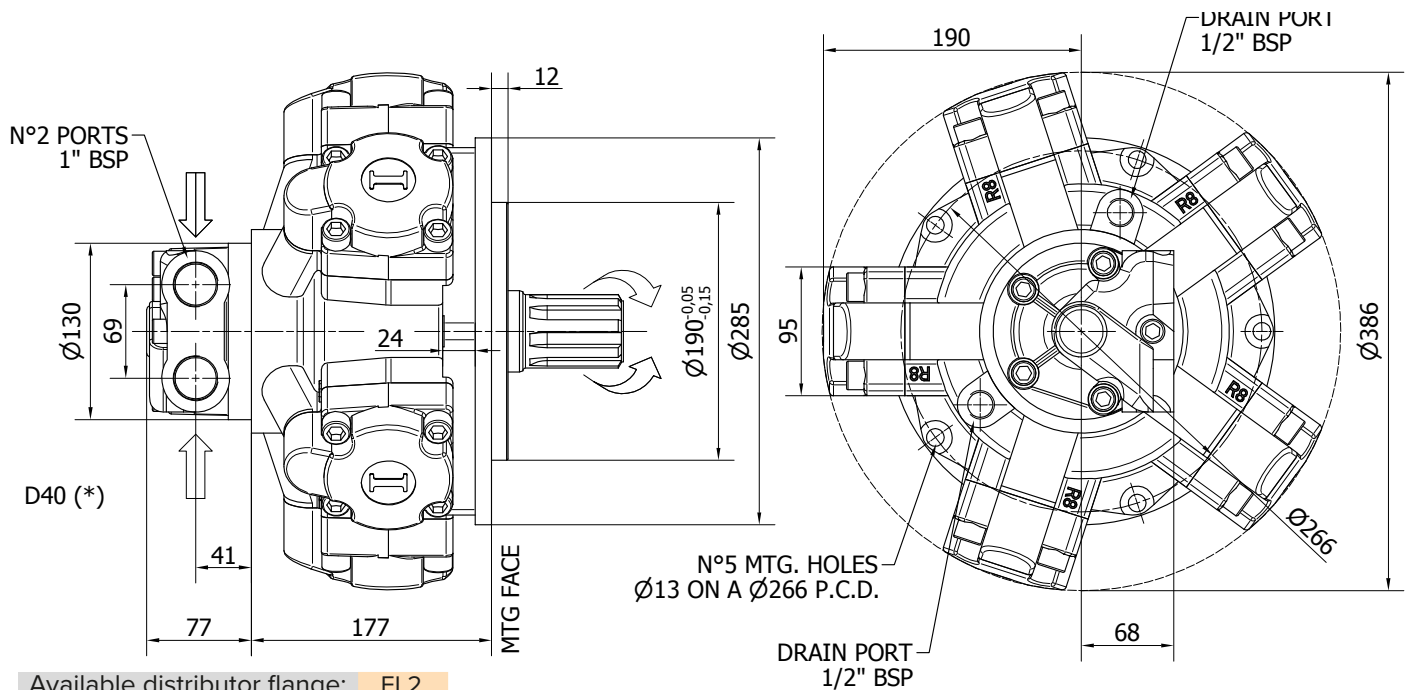

Available distributor flange: **FL2**

Refer to page 186-187
(distributor fitting D47)

TECHNICAL DATA

		350	400	450	500	600	700
DISPLACEMENT	[cc]	342	398	452	492	594	707
SPECIFIC TORQUE	[Nm/bar]	5.4	6.3	7.2	7.8	9.5	11.2
MAX. CONT. PRESSURE	[bar]	270	270	270	270	270	170
HYDROSTATIC TEST PRESSURE	[bar]	420	420	420	420	420	420
MAX. CONT. SPEED	[rpm]	850	750	650	600	500	440
PEAK SPEED (***)	[rpm]	950	860	760	690	570	500
MAX. CONT. POWER (****)	[kW]	85	85	85	85	85	78
MAX. POWER	[kW]	130	130	130	130	130	118
MAX. CASE PRESSURE	[bar]	6	6	6	6	6	6
DRY WEIGHT	[kg]	68	68	68	68	68	68
TEMPERATURE RANGE (**)	[°C]	-30÷70	-30÷70	-30÷70	-30÷70	-30÷70	-30÷70

- (*) The standard distributor (D40) is shown. Please refer to distributors section (pag. 174-175) for different distributor interfaces.

- (**) Please refer to the hydraulic fluid recommendations (pag. 10-11).

- (***) Do not exceed maximum power (see pag. 13).

- (****) For motor operation with a continuous duty cycle at maximum continuous power the flushing is usually required. For more information please contact our technical department.

SHAFTS

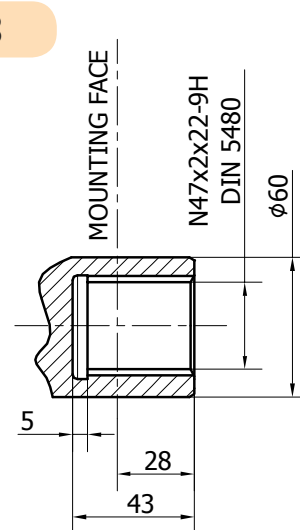
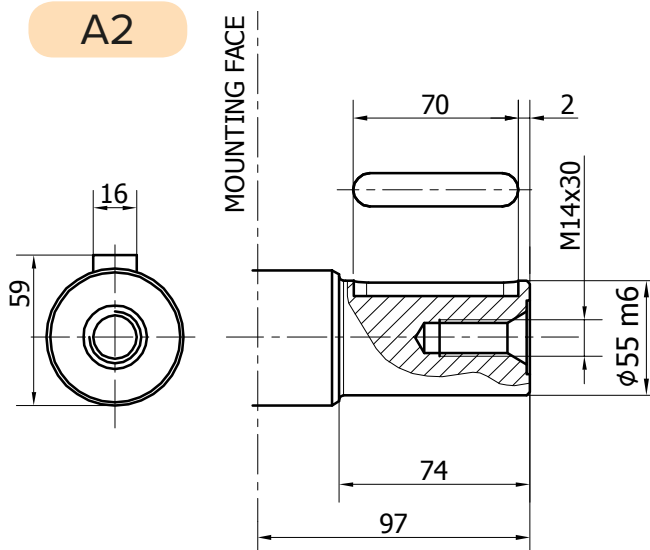
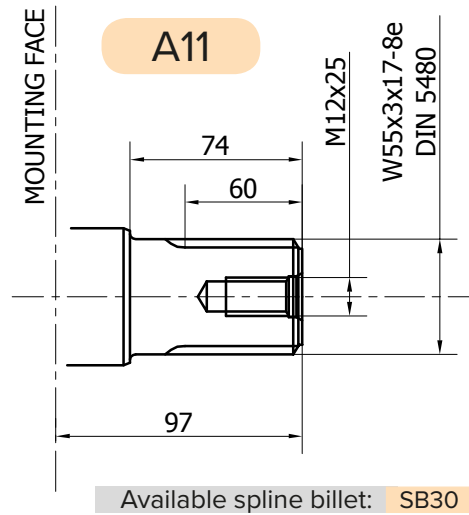
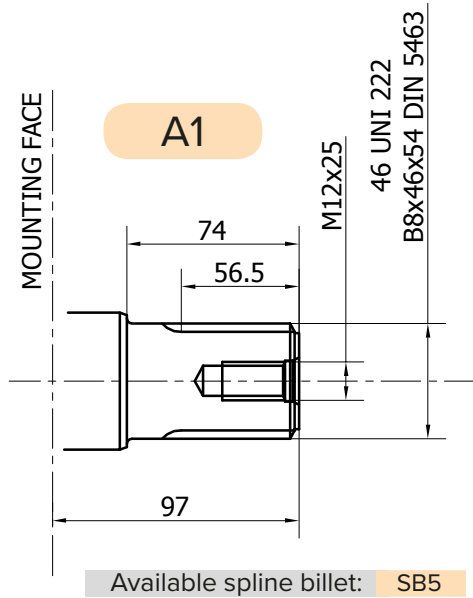

R8D H3/RM

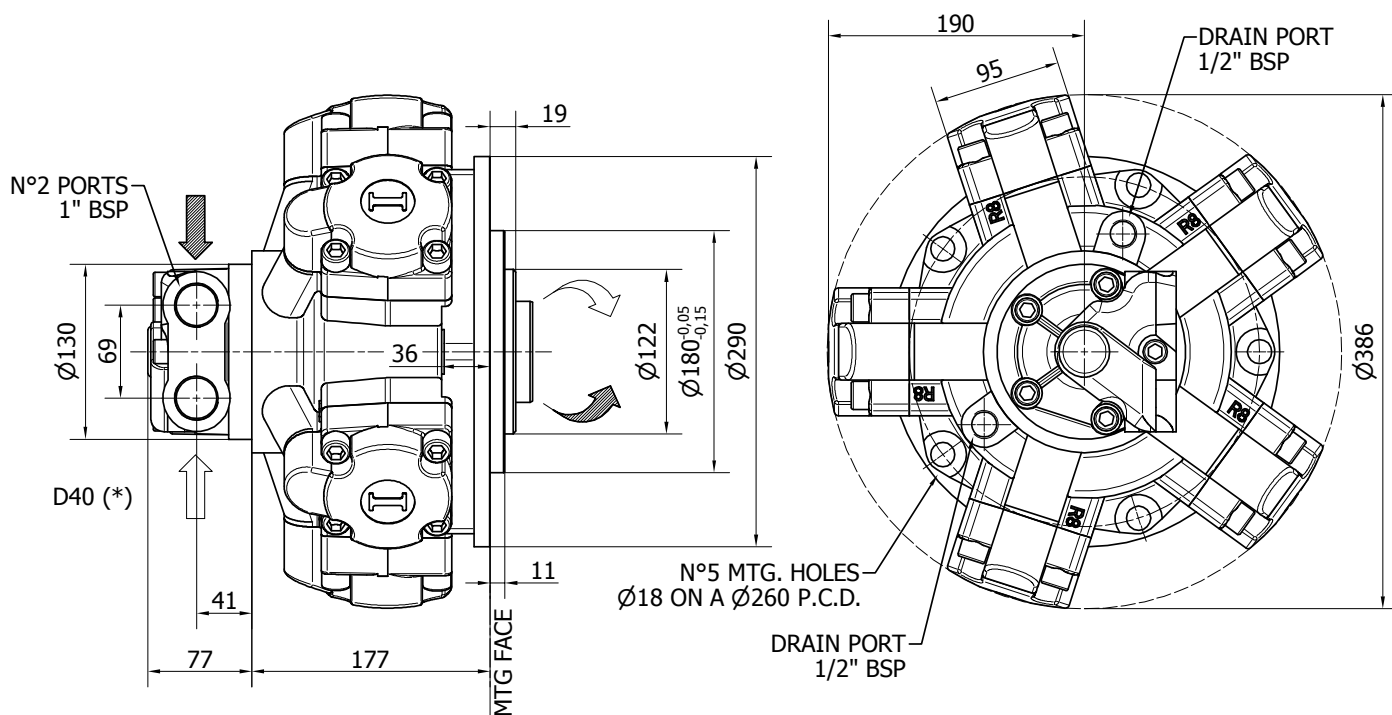

TECHNICAL DATA

		350	400	450	500	600	700
DISPLACEMENT	[cc]	342	398	452	492	594	707
SPECIFIC TORQUE	[Nm/bar]	5.4	6.3	7.2	7.8	9.5	11.2
MAX. CONT. PRESSURE	[bar]	270	270	270	270	270	170
HYDROSTATIC TEST PRESSURE	[bar]	420	420	420	420	420	420
MAX. CONT. SPEED	[rpm]	850	750	650	600	500	440
PEAK SPEED (***)	[rpm]	950	860	760	690	570	500
MAX. CONT. POWER (****)	[kW]	85	85	85	85	85	78
MAX. POWER	[kW]	130	130	130	130	130	118
MAX. CASE PRESSURE	[bar]	6	6	6	6	6	6
DRY WEIGHT	[kg]	68	68	68	68	68	68
TEMPERATURE RANGE (**)	[°C]	-30÷70	-30÷70	-30÷70	-30÷70	-30÷70	-30÷70

- (*) The standard distributor (D40) is shown. Please refer to distributors section (pag. 174-175) for different distributor interfaces.

- (**) Please refer to the hydraulic fluid recommendations (pag. 10-11).

- (***) Do not exceed maximum power (see pag. 13).

- (****) For motor operation with a continuous duty cycle at maximum continuous power the flushing is usually required. For more information please contact our technical department.

SHAFTS

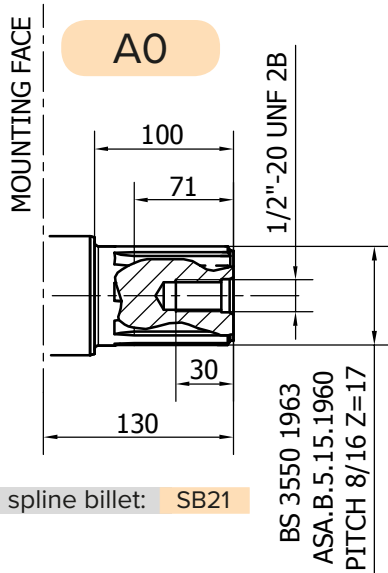

Available spline billet: **SB21**

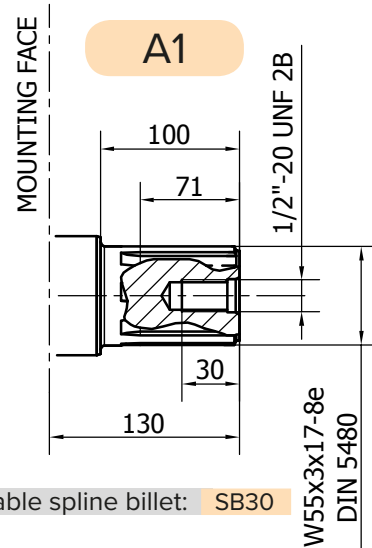

Available spline billet: **SB30**

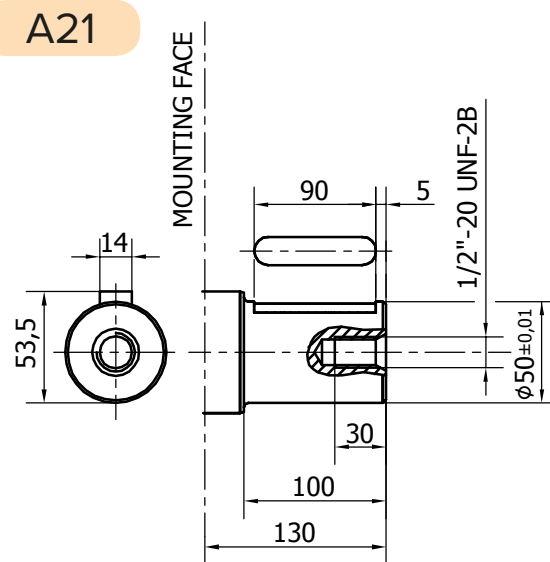
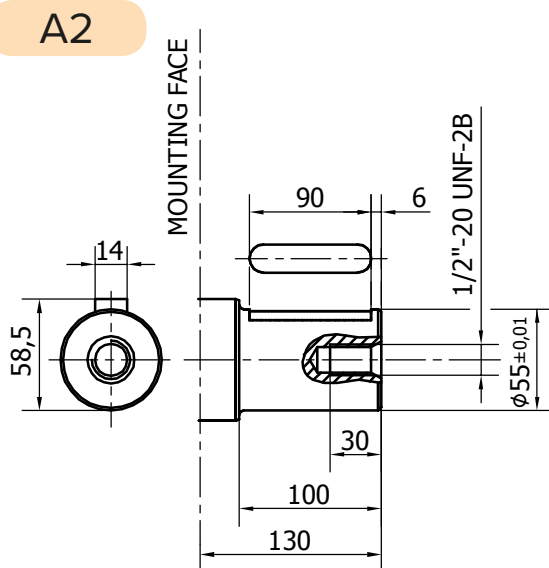

R8D H3/H4C

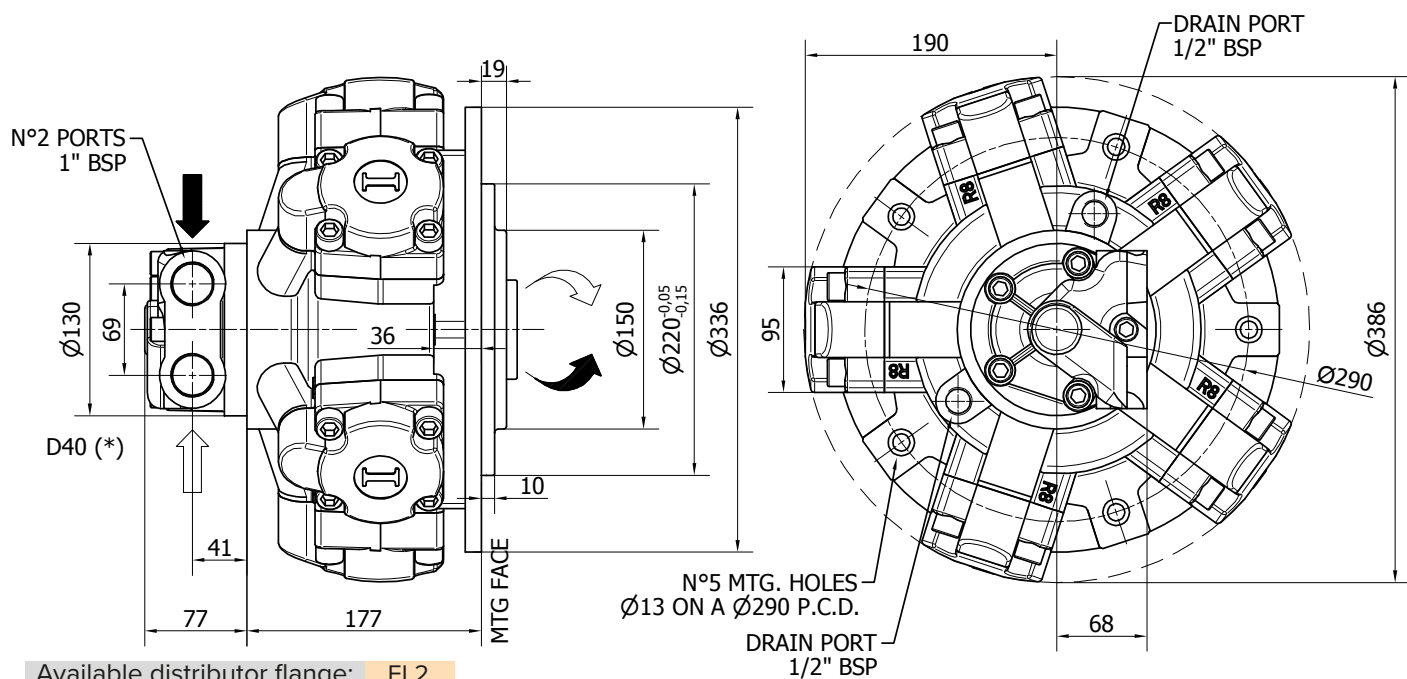

Available distributor flange: **FL2**

Refer to page 186-187
(distributor fitting D47)

TECHNICAL DATA

		350	400	450	500	600	700
DISPLACEMENT	[cc]	342	398	452	492	594	707
SPECIFIC TORQUE	[Nm/bar]	5.4	6.3	7.2	7.8	9.5	11.2
MAX. CONT. PRESSURE	[bar]	270	270	270	270	270	170
HYDROSTATIC TEST PRES-SURE	[bar]	420	420	420	420	420	420
MAX. CONT. SPEED	[rpm]	850	750	650	600	500	440
PEAK SPEED (***)	[rpm]	950	860	760	690	570	500
MAX. CONT. POWER (****)	[kW]	85	85	85	85	85	78
MAX. POWER	[kW]	130	130	130	130	130	118
MAX. CASE PRESSURE	[bar]	6	6	6	6	6	6
DRY WEIGHT	[kg]	68	68	68	68	68	68
TEMPERATURE RANGE (**)	[°C]	-30÷70	-30÷70	-30÷70	-30÷70	-30÷70	-30÷70

- (*) The standard distributor (D40) is shown. Please refer to distributors section (pag. 174-175) for different distributor interfaces.

- (**) Please refer to the hydraulic fluid recommendations (pag. 10-11).

- (***) Do not exceed maximum power (see pag. 13).

- (****) For motor operation with a continuous duty cycle at maximum continuous power the flushing is usually required. For more information please contact our technical department.

SHAFTS

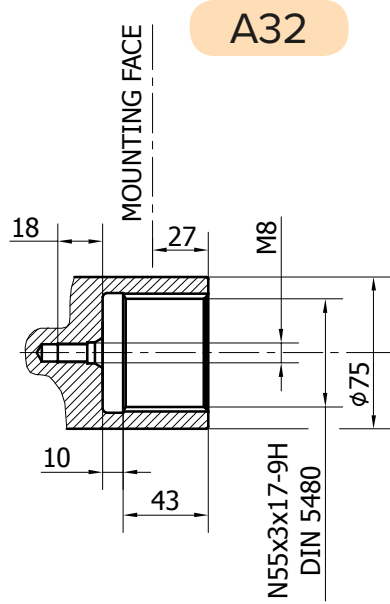

R8D H3 - PERFORMANCE CURVES

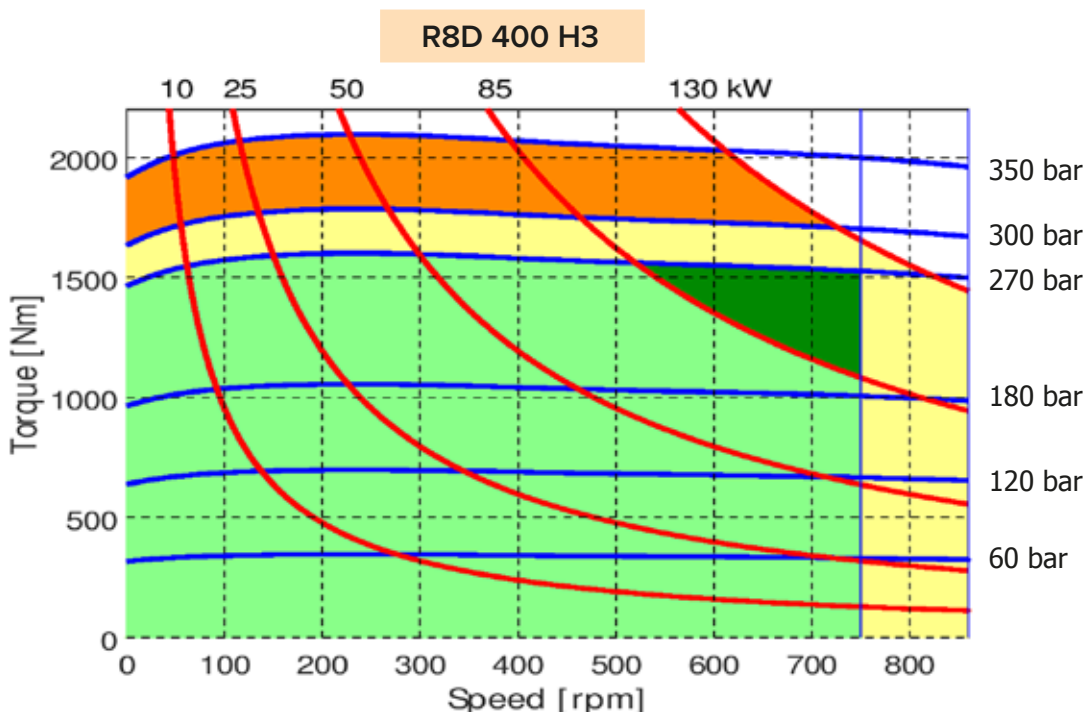
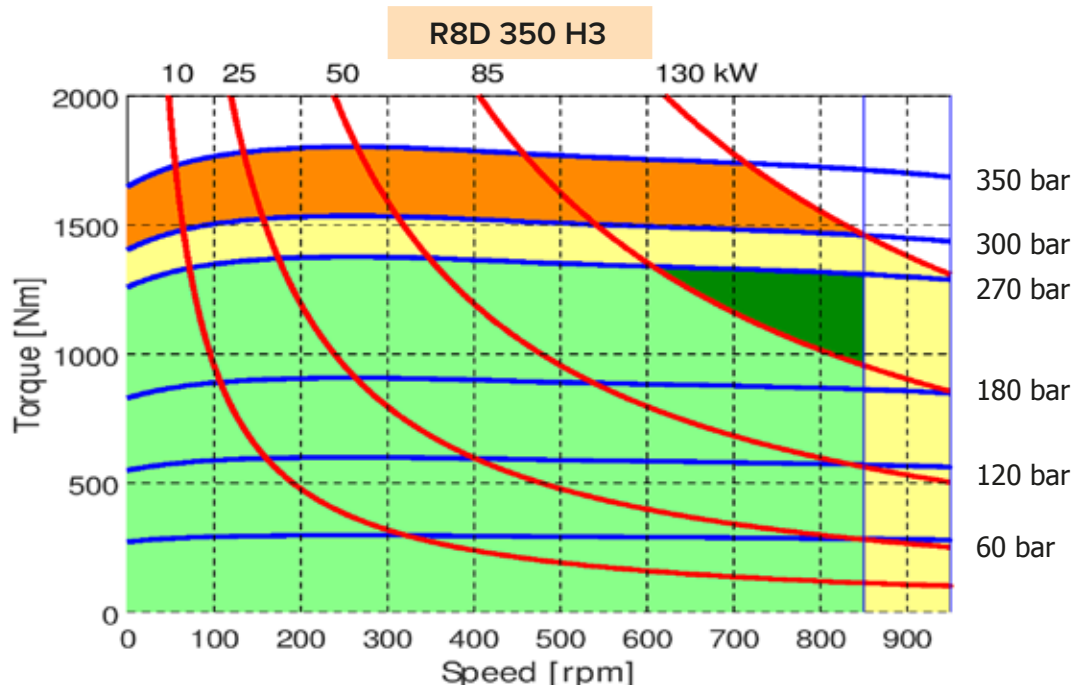

- Continuous operation
- Continuous operation with flushing or intermittent operation (see below for intermittent operation)
- Intermittent operation: permitted for a 15% of duty cycle, for 3 minutes maximum period
- Peak operation: permitted for very short periods (3-5 seconds every 10-15 minutes)

The above diagrams are referring to the hydraulic motor working with a fluid in ideal conditions (viscosity at 40 cSt). In case the working temperature increases and viscosity reach values under the recommended values (see hydraulic fluid recommendations) flushing must be performed or ISO oil grade must be changed. The working temperature must not overcome 70 °C.

R8D 450 H3

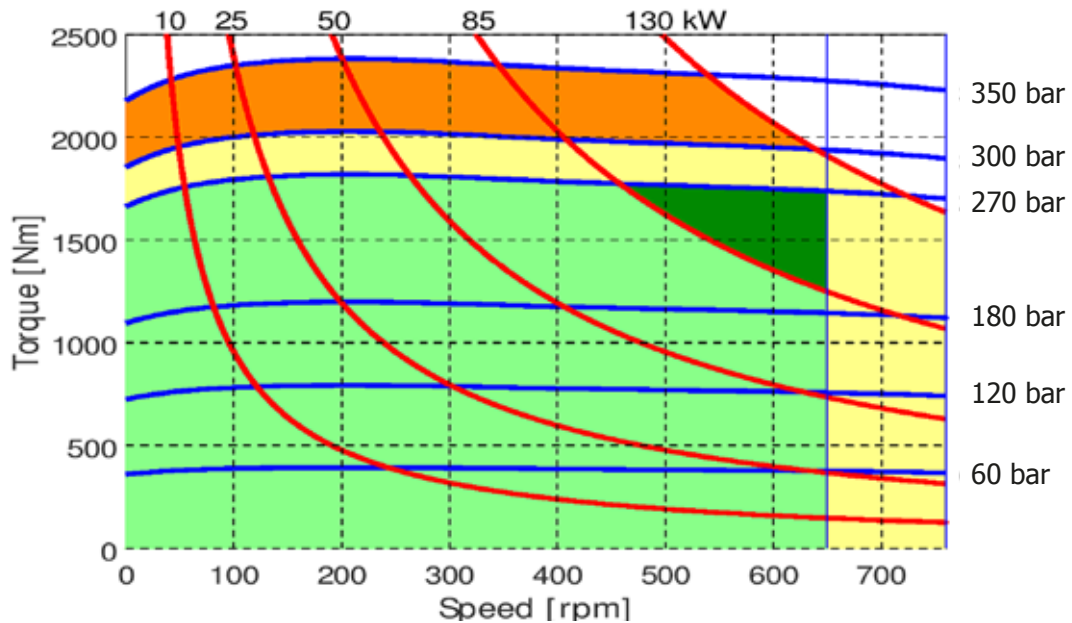

R8D 500 H3

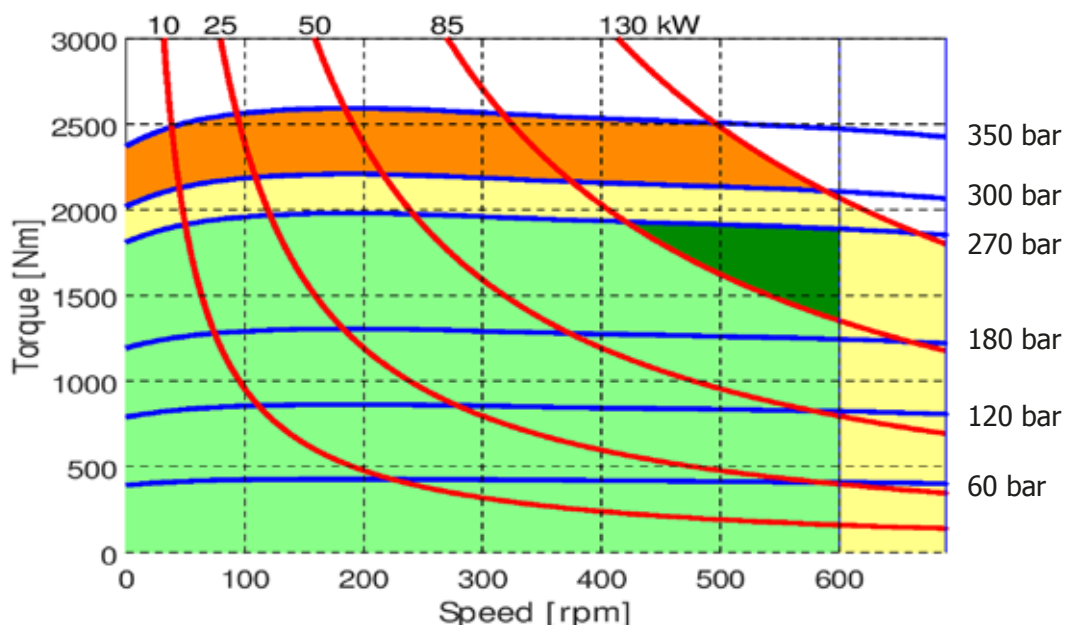

- Continuous operation
- Continuous operation with flushing or intermittent operation (see below for intermittent operation)
- Intermittent operation: permitted for a 15% of duty cycle, for 3 minutes maximum period
- Peak operation: permitted for very short periods (3-5 seconds every 10-15 minutes)

The above diagrams are referring to the hydraulic motor working with a fluid in ideal conditions (viscosity at 40 cSt). In case the working temperature increases and viscosity reach values under the recommended values (see hydraulic fluid recommendations) flushing must be performed or ISO oil grade must be changed. The working temperature must not overcome 70 °C.

R8D H3 - PERFORMANCE CURVES

R8D 600 H3

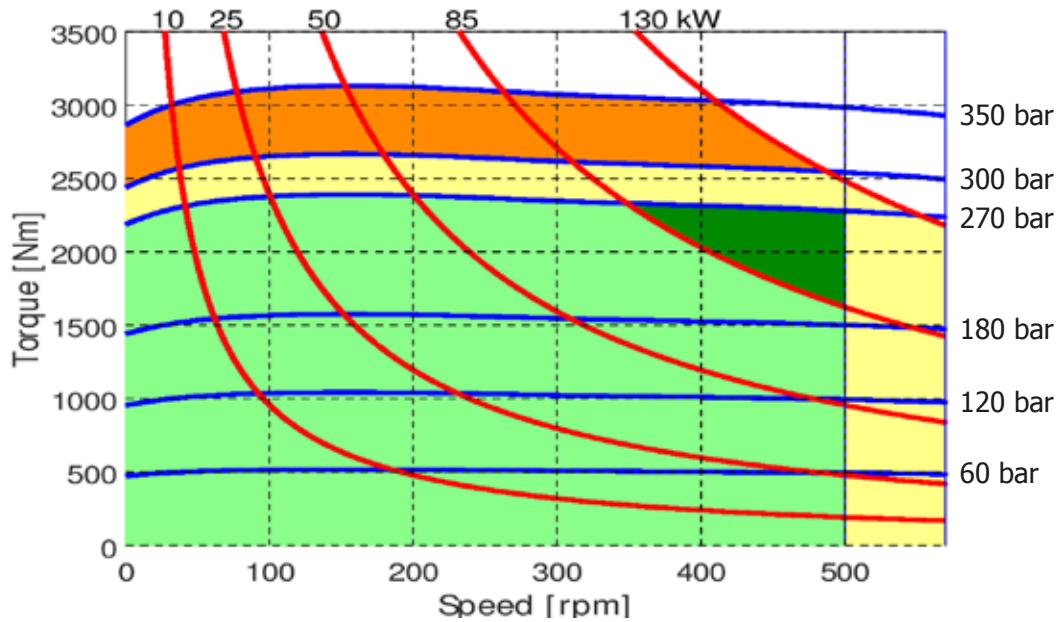

R8D 700 H3

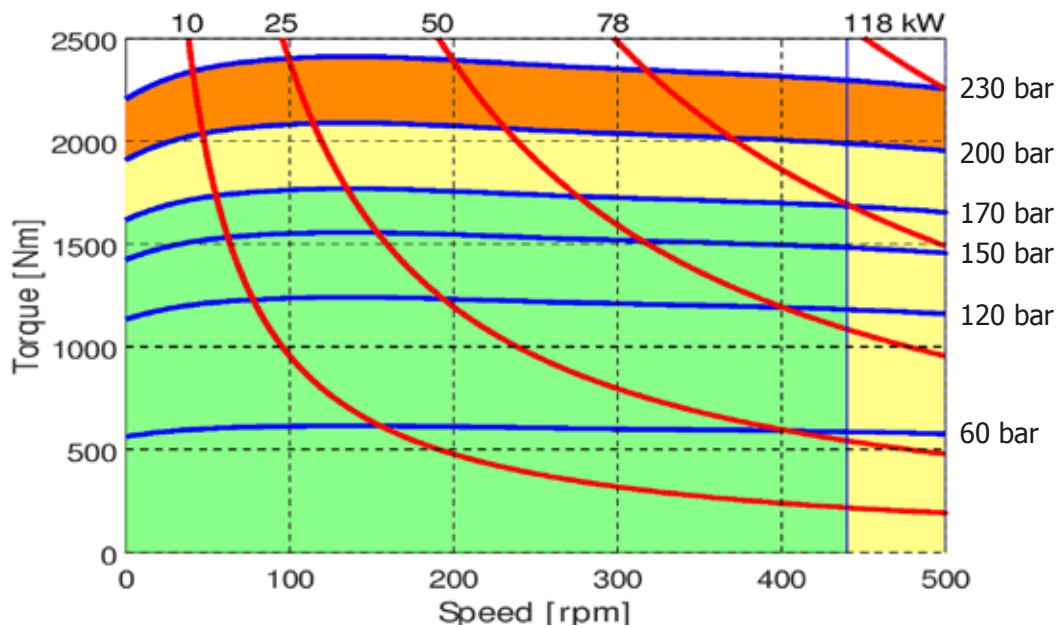

- Continuous operation
- Continuous operation with flushing or intermittent operation (see below for intermittent operation)
- Intermittent operation: permitted for a 15% of duty cycle, for 3 minutes maximum period
- Peak operation: permitted for very short periods (3-5 seconds every 10-15 minutes)

The above diagrams are referring to the hydraulic motor working with a fluid in ideal conditions (viscosity at 40 cSt). In case the working temperature increases and viscosity reach values under the recommended values (see hydraulic fluid recommendations) flushing must be performed or ISO oil grade must be changed. The working temperature must not overcome 70 °C.

CREEP SPEED - VOLUMETRIC EFFICIENCY

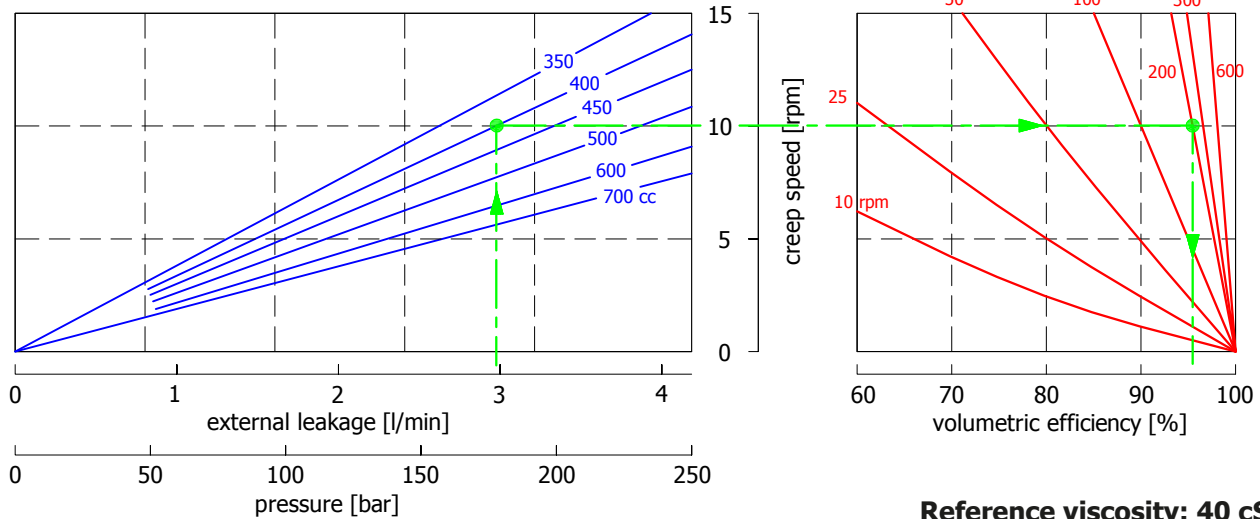

Reference viscosity: 40 cSt

Example:

We suppose (500 cc): $p=175$ [bar], we obtain: external leakage 3 [l/min], shaft creep speed 10 [rpm].
 If we suppose (500 cc): $p=175$ [bar] and $n=200$ [rpm] we obtain a volumetric efficiency of 95%;

BEARING LIFE

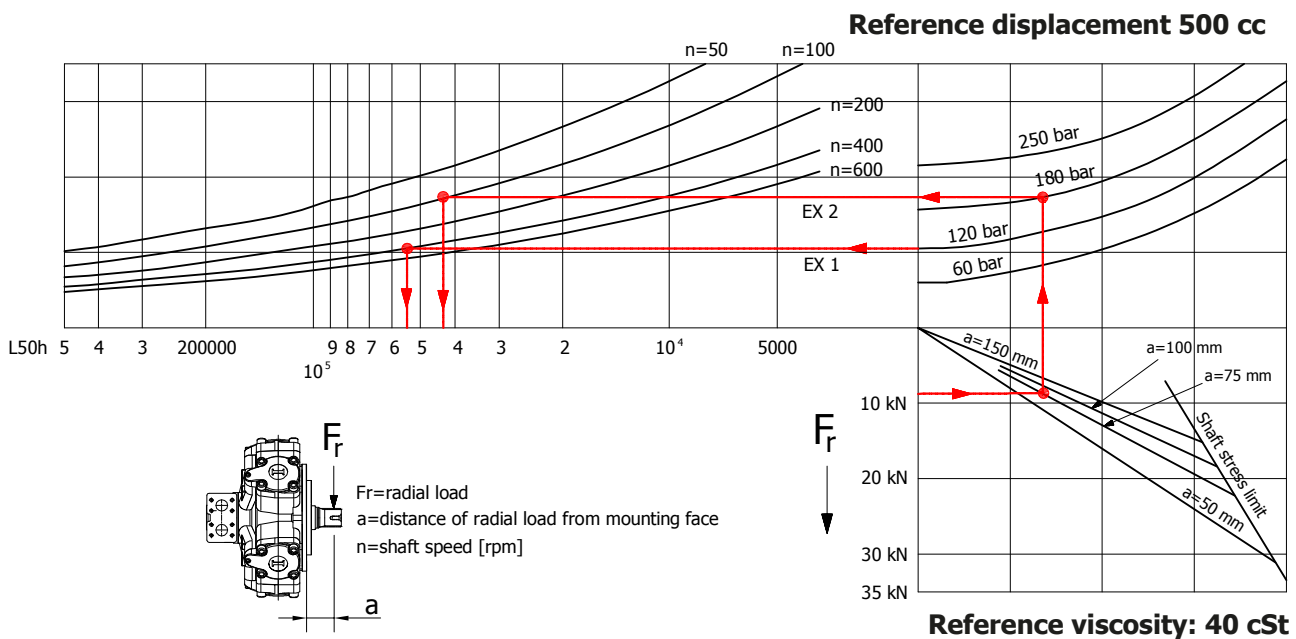

Reference viscosity: 40 cSt

Example:

We suppose (EX1): $p=120$ [bar], $n=400$ [rpm]; we obtain an average lifetime of 53000 [h].
 If we suppose (EX2): $F_r=9$ [kN], $a=75$ [mm], $n=100$ [rpm] and $p=180$ [bar] we obtain an average lifetime of 42000 [h].

R8D H3 - ORDERING CODE

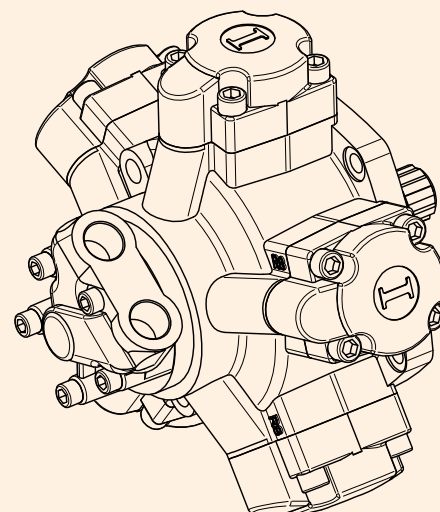
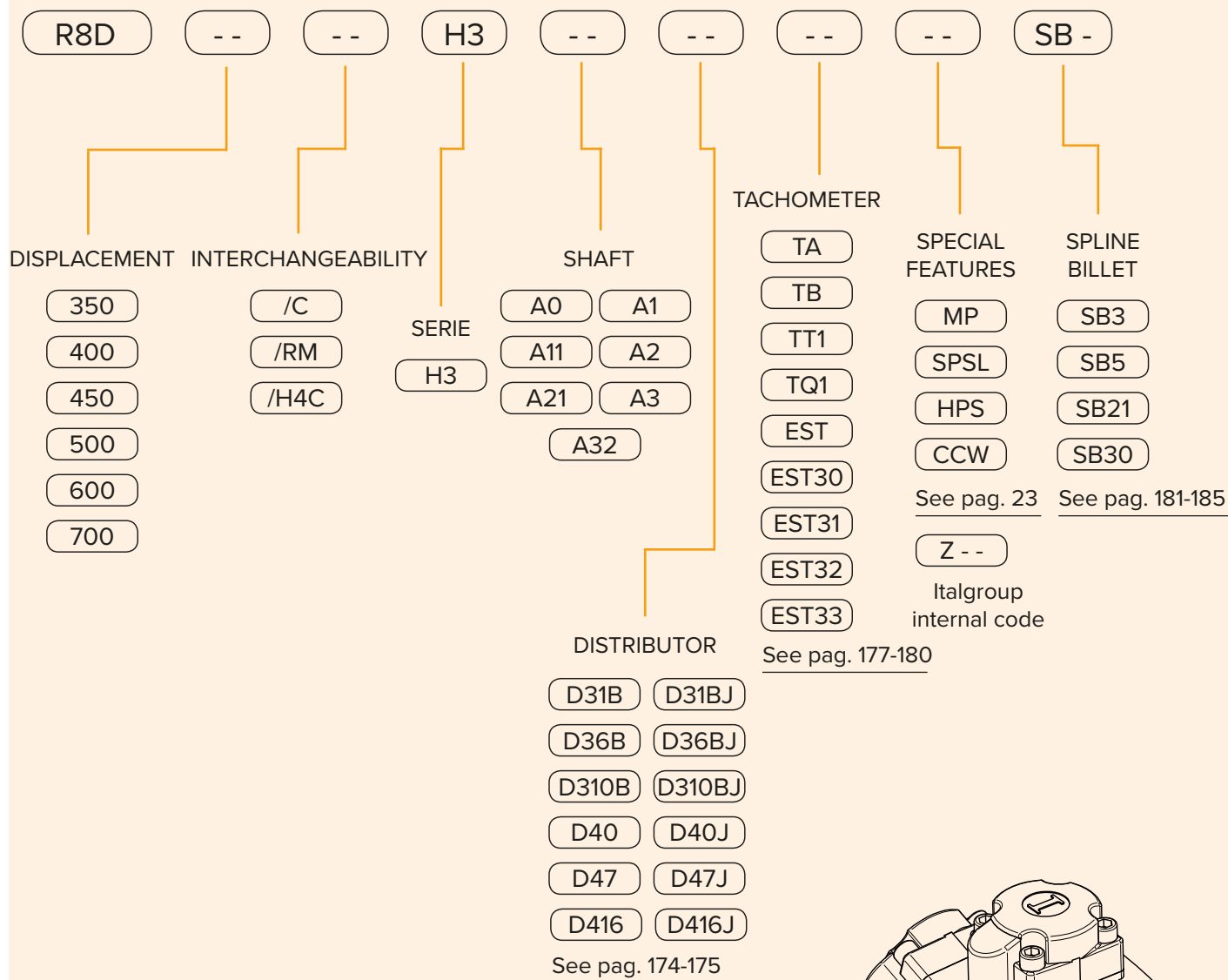

EXAMPLES:

R8D 600 H3 A2 D416
R8D 450/C H3 A1 D40 CCW SB5
R8D 600 H3 A0 D40 EST31

R8D H4

R8D H4	Pag. 52 - 53
R8D H4/C	Pag. 54 - 55
R8D H4/B45	Pag. 56 - 57
R8D H4/GM4	Pag. 58 - 59
R8D H4/S	Pag. 60 - 61
R8D H4/SB506	Pag. 62 - 63
R8D H4 - PERFORMANCE CURVES	Pag. 64 - 68
R8D H4 - ORDERING CODE	Pag. 69

SHAFTS

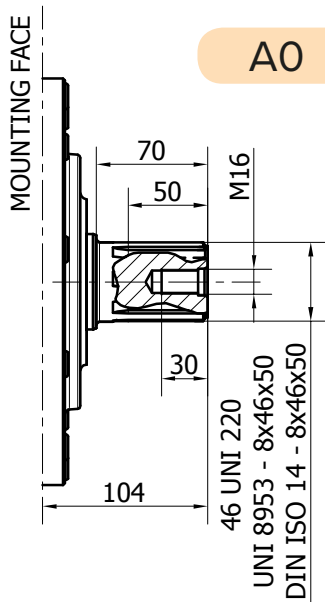

Available spline billet: SB4

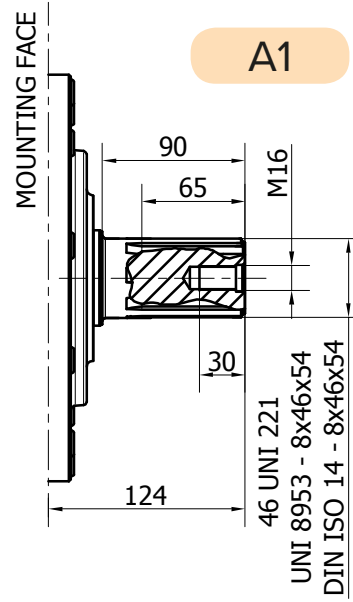

Available spline billet: SB5

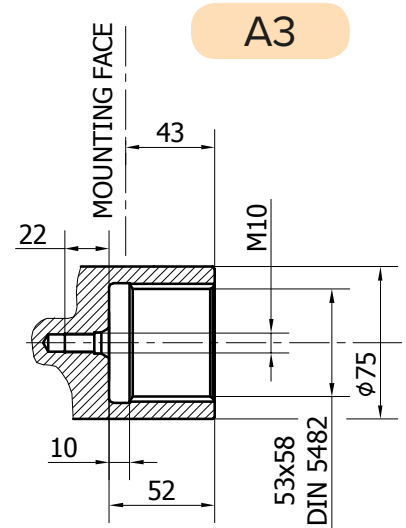
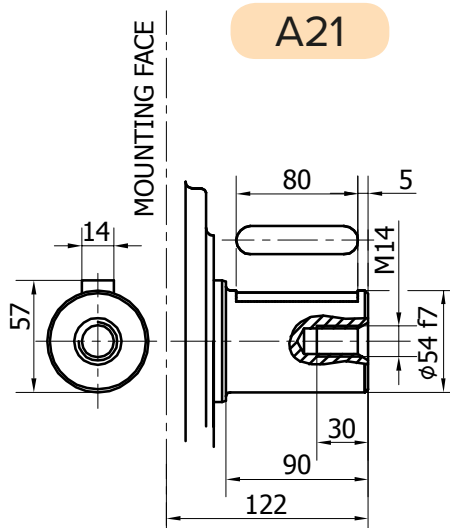
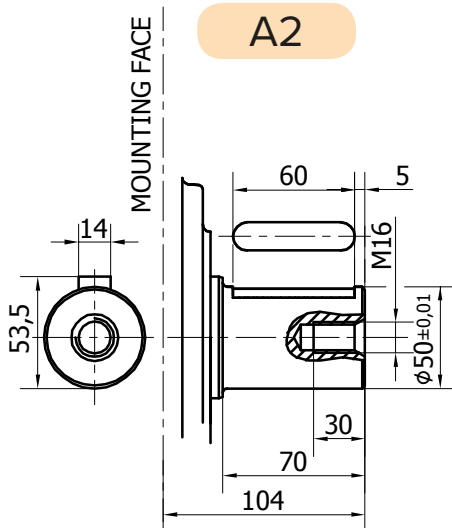

R8D H4/C

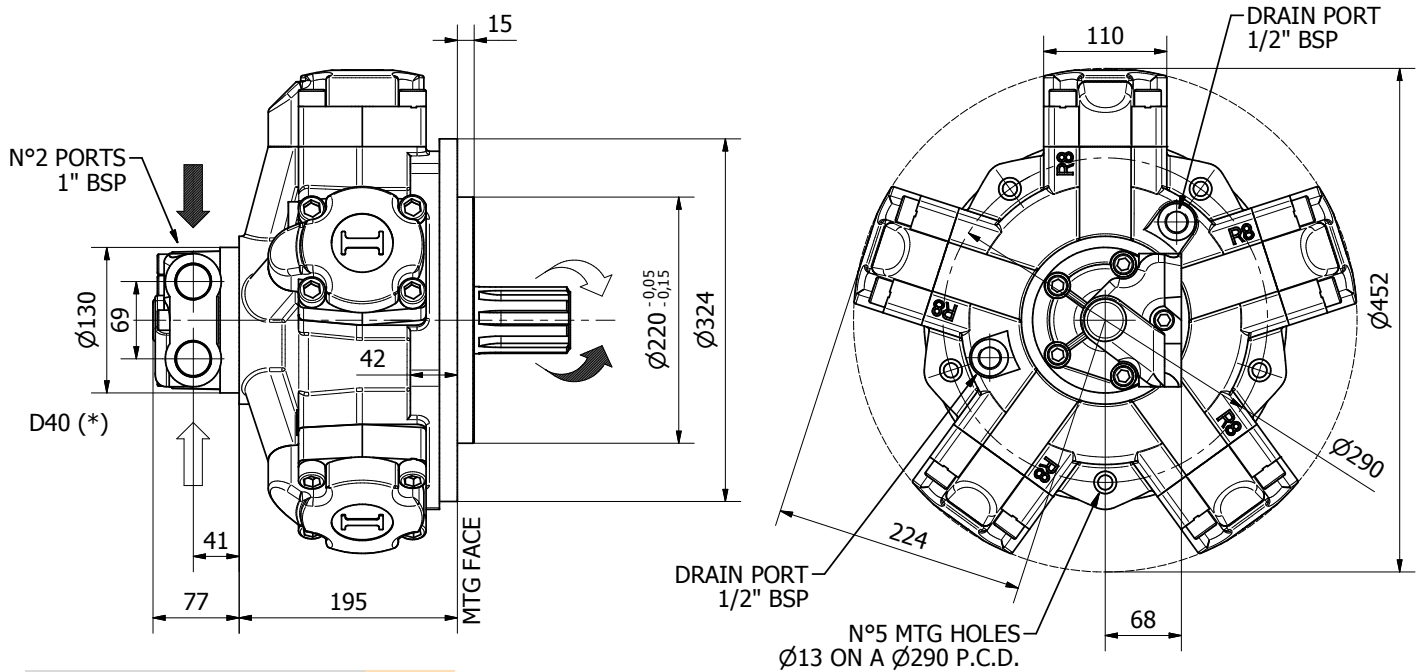

Available distributor flange: **FL2**

Refer to page 186-187
(distributor fitting D47)

TECHNICAL DATA

		500	600	700	800	850	900	1000	1250
DISPLACEMENT	[cc]	493	584	714	792	847	904	992	1247
SPECIFIC TORQUE	[Nm/bar]	7.8	9.3	11.4	12.6	13.5	14.4	15.8	19.8
MAX. CONT. PRESSURE	[bar]	270	270	270	270	270	270	270	200
HYDROSTATIC TEST PRESSURE	[bar]	420	420	420	420	420	420	420	420
MAX. CONT. SPEED	[rpm]	700	700	500	450	420	400	355	280
PEAK SPEED (**)	[rpm]	800	800	580	530	490	460	405	320
MAX. CONT. POWER (***)	[kW]	130	130	130	130	130	130	130	102
MAX. POWER	[kW]	160	160	160	160	160	160	160	130
MAX. CASE PRESSURE	[bar]	6	6	6	6	6	6	6	6
DRY WEIGHT	[kg]	92	92	92	92	92	92	92	92
TEMPERATURE RANGE (**)	[°C]	-30÷70	-30÷70	-30÷70	-30÷70	-30÷70	-30÷70	-30÷70	-30÷70

- (*) The standard distributor (D40) is shown. Please refer to distributors section (pag. 174-175) for different distributor interfaces.

- (**) Please refer to the hydraulic fluid recommendations (pag. 10-11).

- (***) Do not exceed maximum power (see pag. 13).

- (****) For motor operation with a continuous duty cycle at maximum continuous power the flushing is usually required. For more information please contact our technical department.

SHAFTS

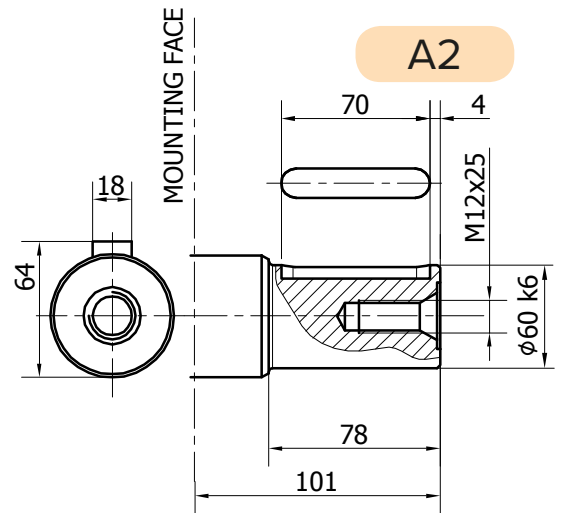
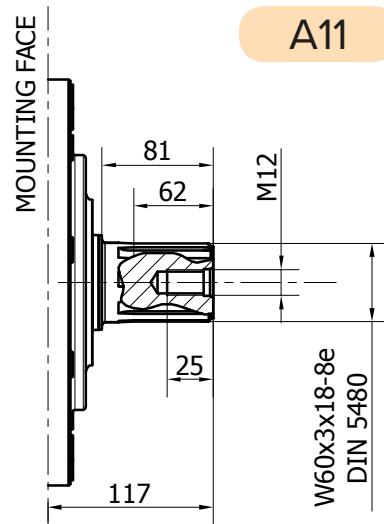
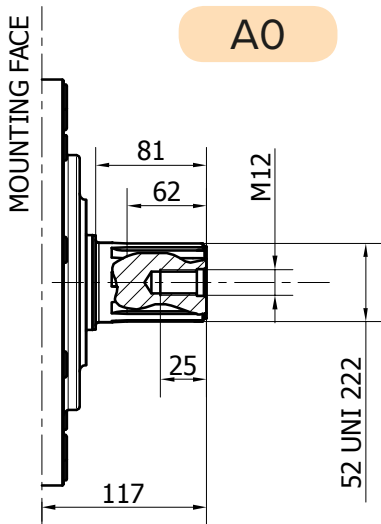

Available spline billet: SB16

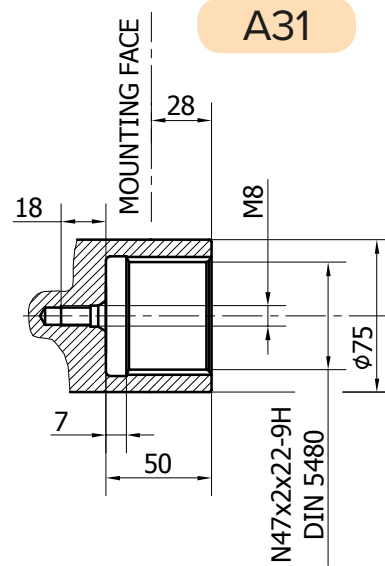
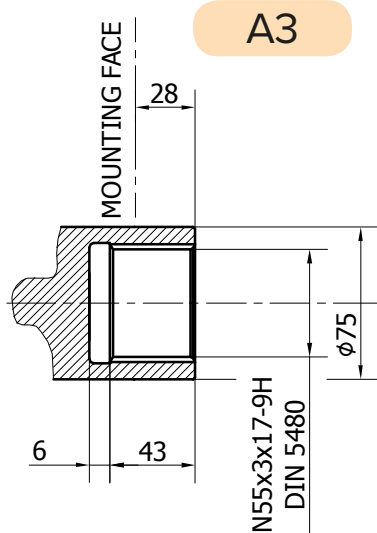

R8D H4/B45

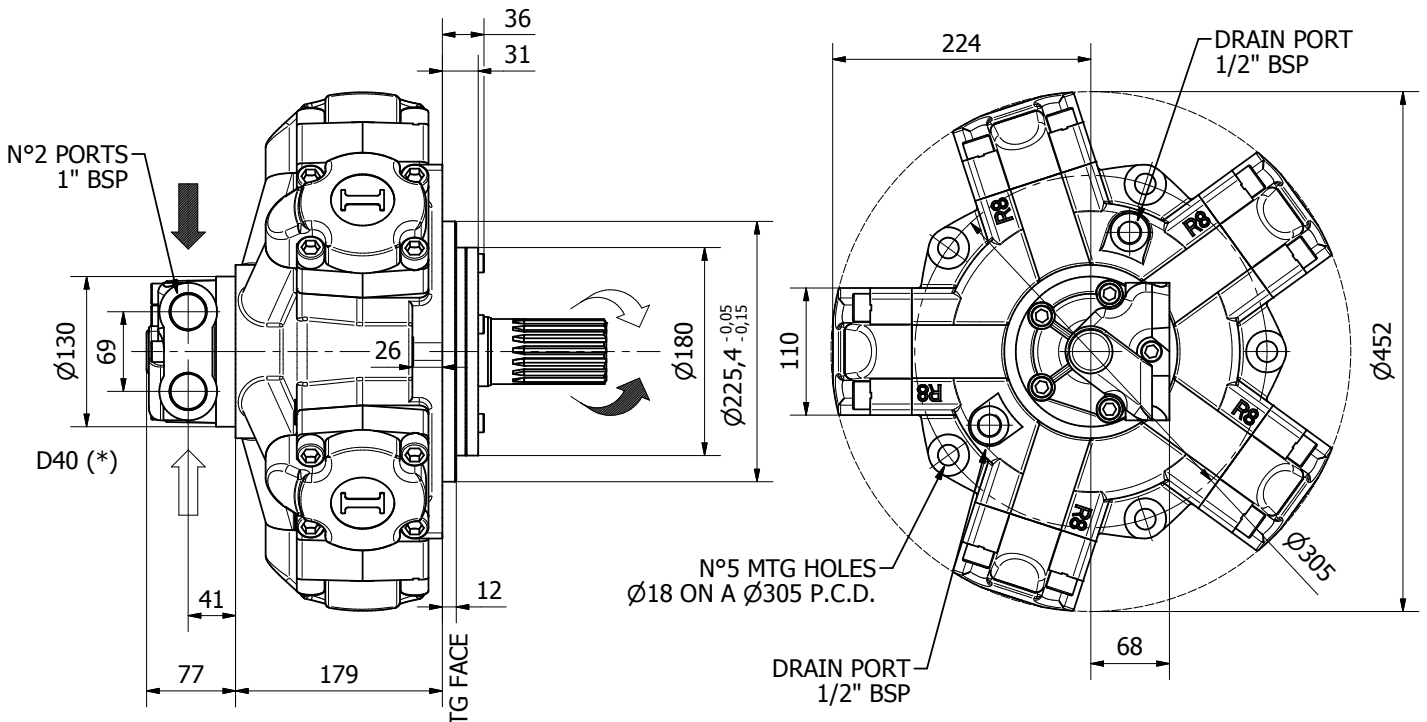

TECHNICAL DATA

		500	600	700	800	850	900	1000	1250
DISPLACEMENT	[cc]	493	584	714	792	847	904	992	1247
SPECIFIC TORQUE	[Nm/bar]	7.8	9.3	11.4	12.6	13.5	14.4	15.8	19.8
MAX. CONT. PRESSURE	[bar]	270	270	270	270	270	270	270	200
HYDROSTATIC TEST PRESSURE	[bar]	420	420	420	420	420	420	420	420
MAX. CONT. SPEED	[rpm]	700	700	500	450	420	400	355	280
PEAK SPEED (***)	[rpm]	800	800	580	530	490	460	405	320
MAX. CONT. POWER (****)	[kW]	130	130	130	130	130	130	130	102
MAX. POWER	[kW]	160	160	160	160	160	160	160	130
MAX. CASE PRESSURE	[bar]	6	6	6	6	6	6	6	6
DRY WEIGHT	[kg]	92	92	92	92	92	92	92	92
TEMPERATURE RANGE (**)	[°C]	-30÷70	-30÷70	-30÷70	-30÷70	-30÷70	-30÷70	-30÷70	-30÷70

- (*) The standard distributor (D40) is shown. Please refer to distributors section (pag. 174-175) for different distributor interfaces.

- (**) Please refer to the hydraulic fluid recommendations (pag. 10-11).

- (***) Do not exceed maximum power (see pag. 13).

- (****) For motor operation with a continuous duty cycle at maximum continuous power the flushing is usually required. For more information please contact our technical department.

SHAFTS

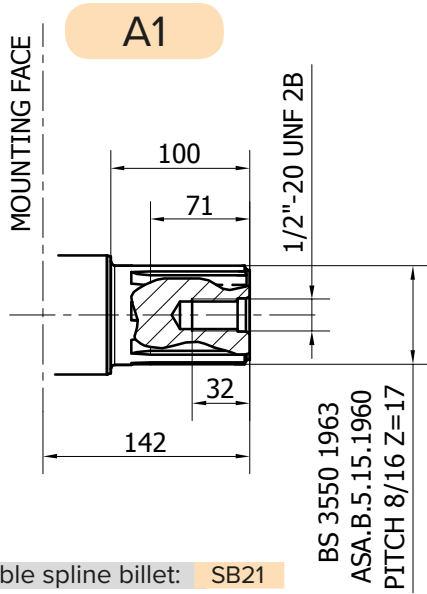

Available spline billet: SB21

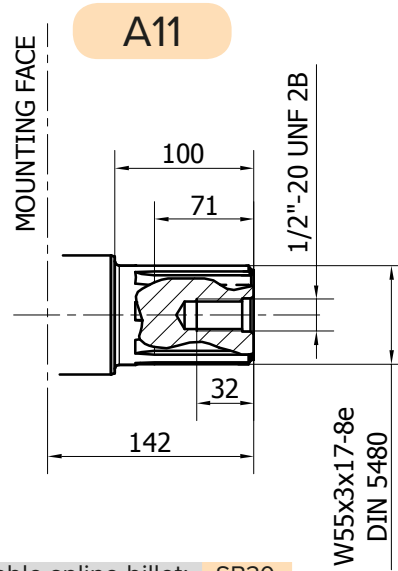

Available spline billet: SB30

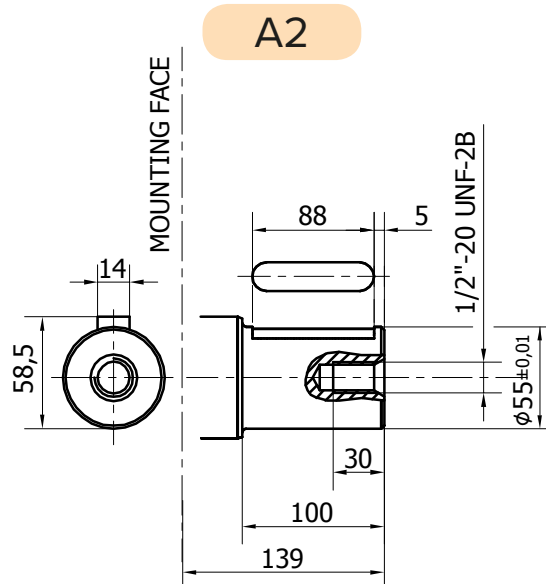

R8D H4/GM4

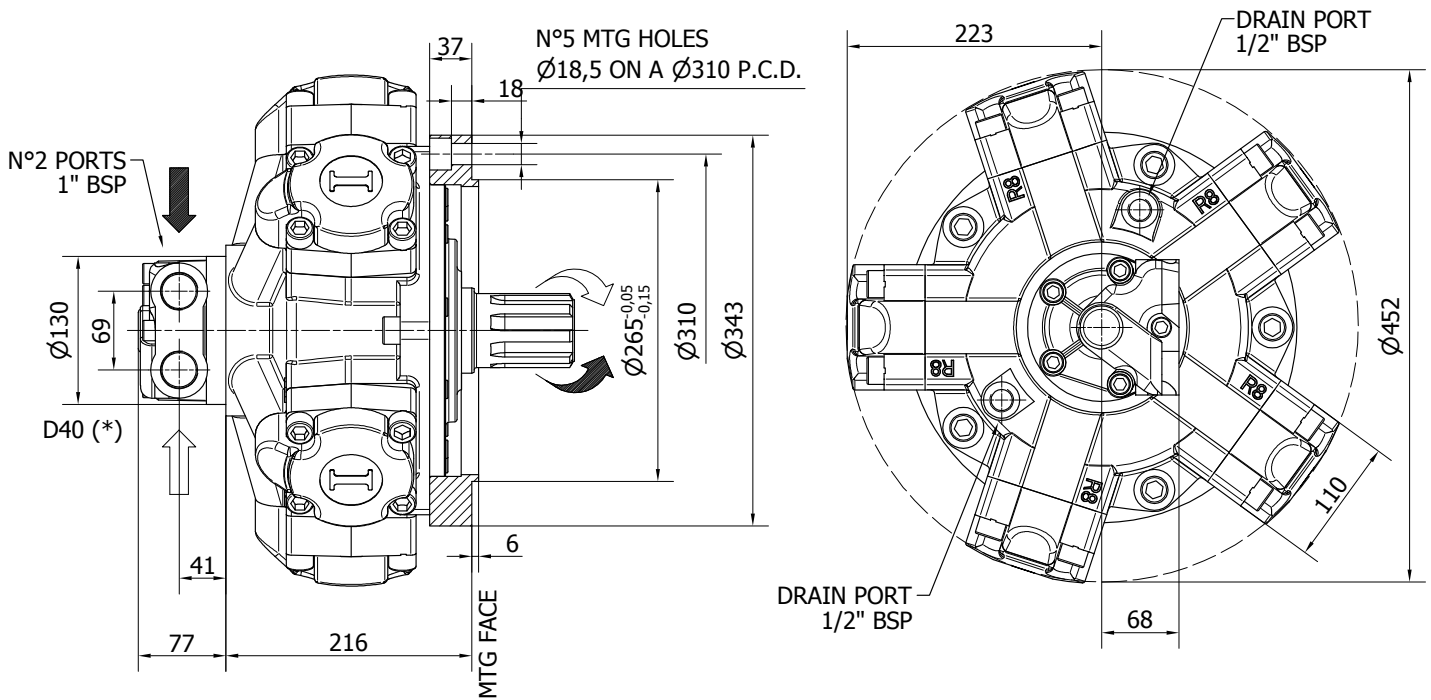

TECHNICAL DATA

		500	600	700	800	850	900	1000	1250
DISPLACEMENT	[cc]	493	584	714	792	847	904	992	1247
SPECIFIC TORQUE	[Nm/bar]	7.8	9.3	11.4	12.6	13.5	14.4	15.8	19.8
MAX. CONT. PRESSURE	[bar]	270	270	270	270	270	270	270	200
HYDROSTATIC TEST PRESSURE	[bar]	420	420	420	420	420	420	420	420
MAX. CONT. SPEED	[rpm]	700	700	500	450	420	400	355	280
PEAK SPEED (***)	[rpm]	800	800	580	530	490	460	405	320
MAX. CONT. POWER (****)	[kW]	130	130	130	130	130	130	130	102
MAX. POWER	[kW]	160	160	160	160	160	160	160	130
MAX. CASE PRESSURE	[bar]	6	6	6	6	6	6	6	6
DRY WEIGHT	[kg]	92	92	92	92	92	92	92	92
TEMPERATURE RANGE (**)	[°C]	-30÷70	-30÷70	-30÷70	-30÷70	-30÷70	-30÷70	-30÷70	-30÷70

- (*) The standard distributor (D40) is shown. Please refer to distributors section (pag. 174-175) for different distributor interfaces.

- (**) Please refer to the hydraulic fluid recommendations (pag. 10-11).

- (***) Do not exceed maximum power (see pag. 13).

- (****) For motor operation with a continuous duty cycle at maximum continuous power the flushing is usually required. For more information please contact our technical department.

SHAFTS

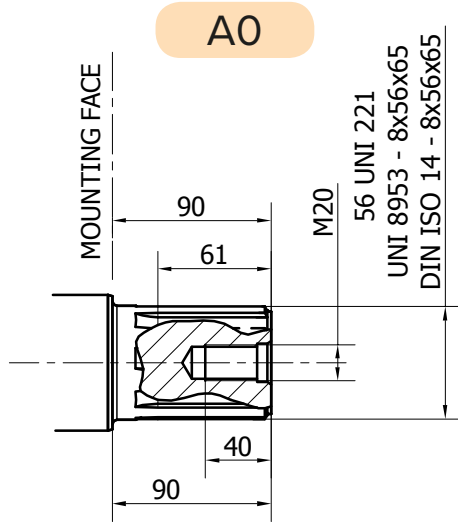

Available spline billet: SB17

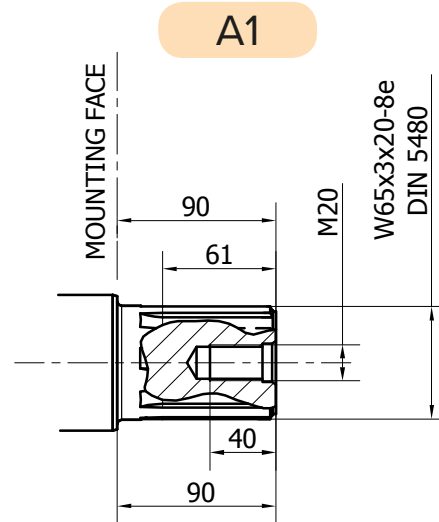

Available spline billet: SB23

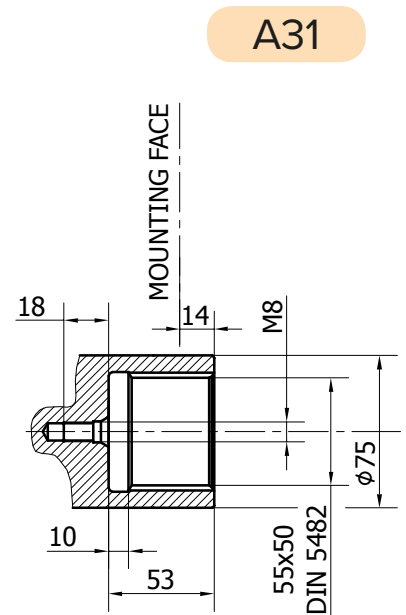
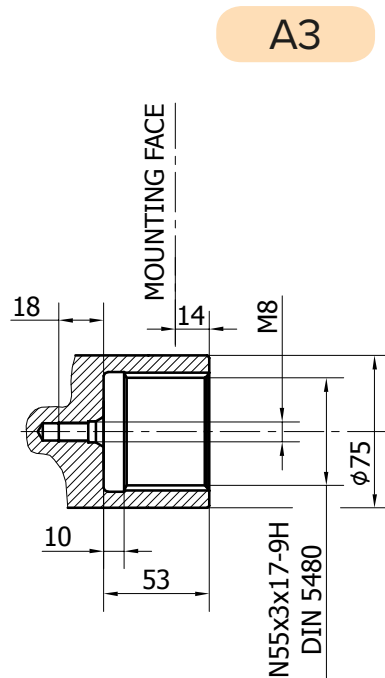
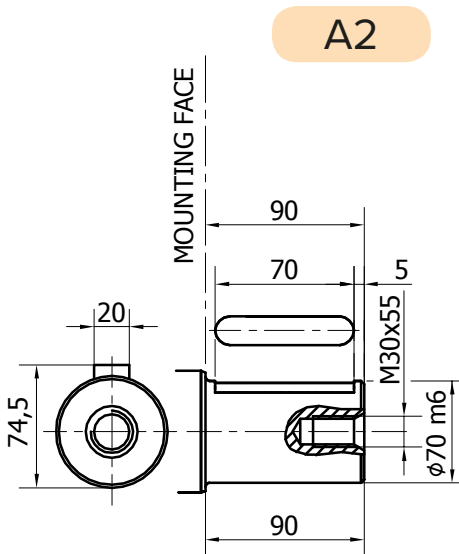

R8D H4/S

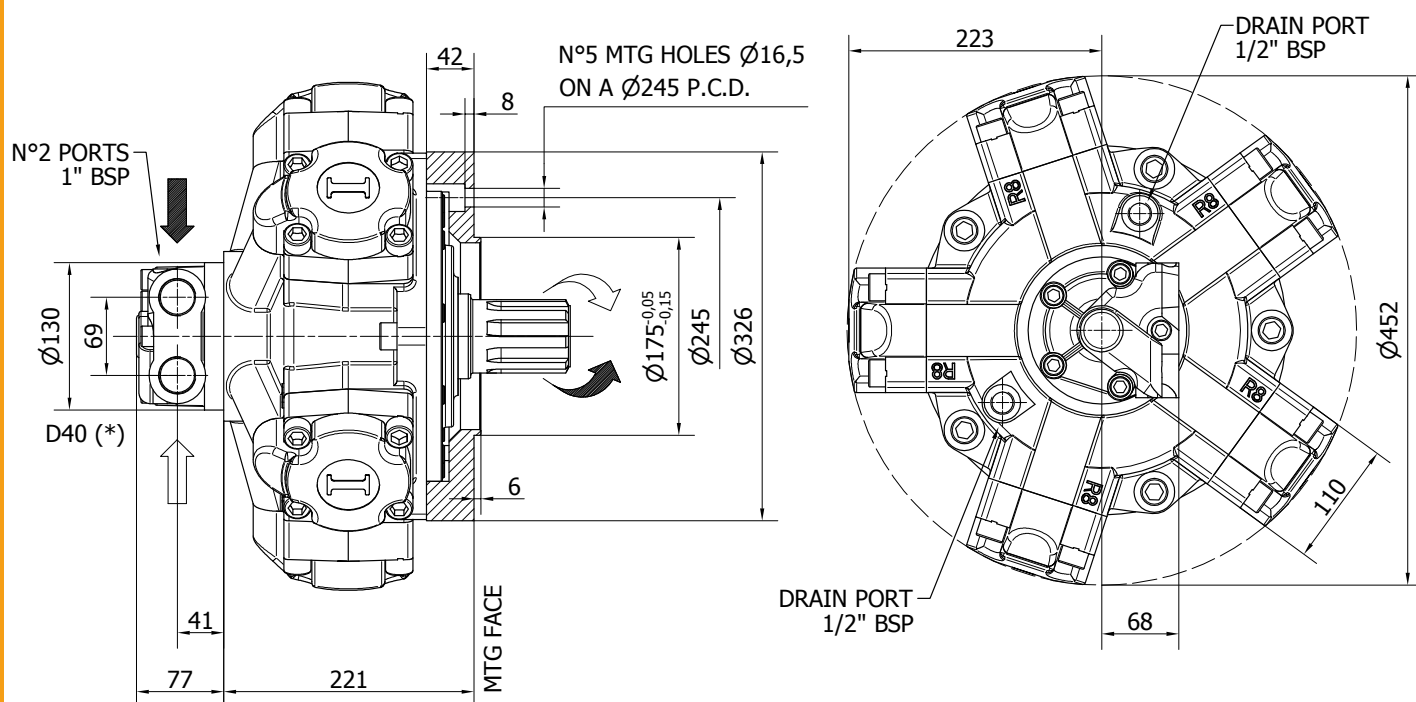

TECHNICAL DATA

		500	600	700	800	850	900	1000	1250
DISPLACEMENT	[cc]	493	584	714	792	847	904	992	1247
SPECIFIC TORQUE	[Nm/bar]	7.8	9.3	11.4	12.6	13.5	14.4	15.8	19.8
MAX. CONT. PRESSURE	[bar]	270	270	270	270	270	270	270	200
HYDROSTATIC TEST PRESSURE	[bar]	420	420	420	420	420	420	420	420
MAX. CONT. SPEED	[rpm]	700	700	500	450	420	400	355	280
PEAK SPEED (***)	[rpm]	800	800	580	530	490	460	405	320
MAX. CONT. POWER (****)	[kW]	130	130	130	130	130	130	130	102
MAX. POWER	[kW]	160	160	160	160	160	160	160	130
MAX. CASE PRESSURE	[bar]	6	6	6	6	6	6	6	6
DRY WEIGHT	[kg]	92	92	92	92	92	92	92	92
TEMPERATURE RANGE (**)	[°C]	-30÷70	-30÷70	-30÷70	-30÷70	-30÷70	-30÷70	-30÷70	-30÷70

- (*) The standard distributor (D40) is shown. Please refer to distributors section (pag. 174-175) for different distributor interfaces.

- (**) Please refer to the hydraulic fluid recommendations (pag. 10-11).

- (***) Do not exceed maximum power (see pag. 13).

- (****) For motor operation with a continuous duty cycle at maximum continuous power the flushing is usually required. For more information please contact our technical department.

SHAFTS

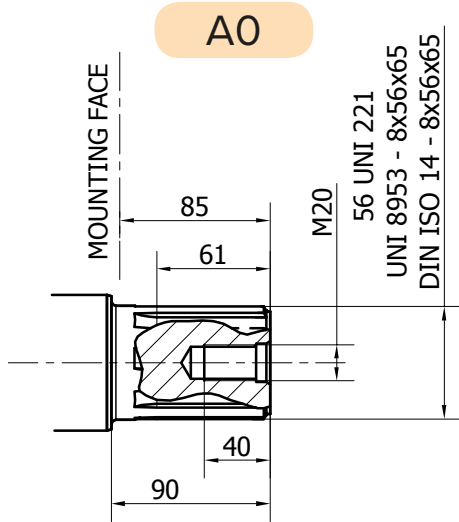

Available spline billet: SB17

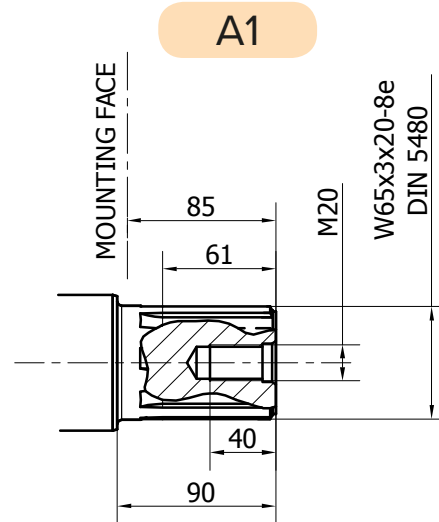

Available spline billet: SB23

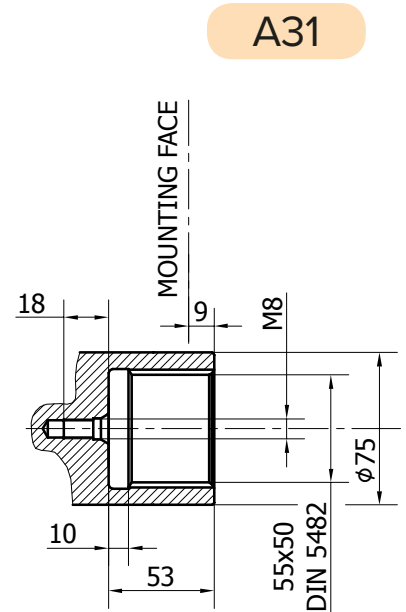
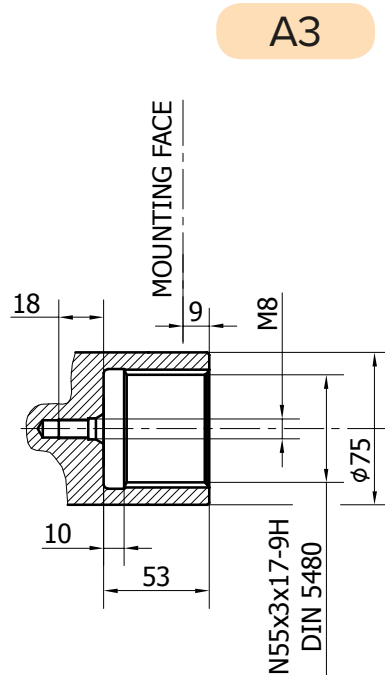
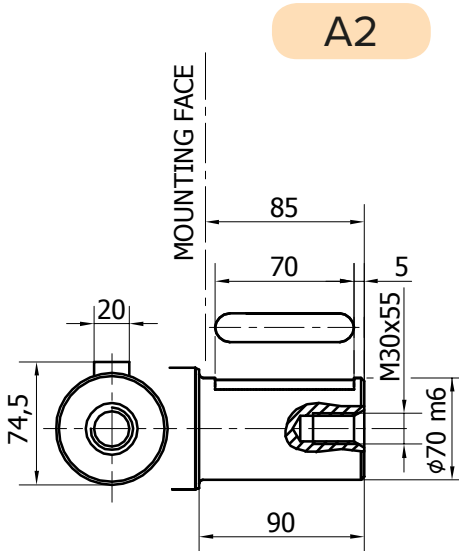

R8D H4/SB506

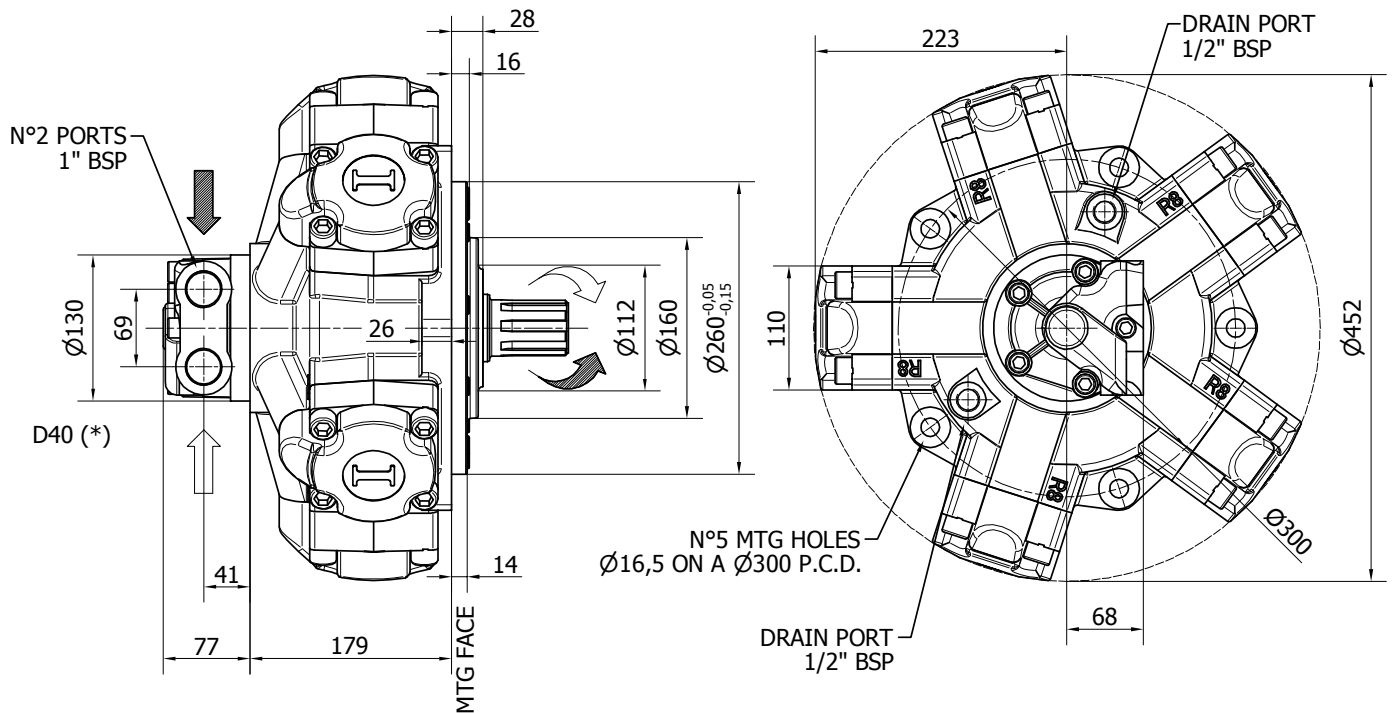

TECHNICAL DATA

		500	600	700	800	850	900	1000	1250
DISPLACEMENT	[cc]	493	584	714	792	847	904	992	1247
SPECIFIC TORQUE	[Nm/bar]	7.8	9.3	11.4	12.6	13.5	14.4	15.8	19.8
MAX. CONT. PRESSURE	[bar]	270	270	270	270	270	270	270	200
HYDROSTATIC TEST PRESSURE	[bar]	420	420	420	420	420	420	420	420
MAX. CONT. SPEED	[rpm]	700	700	500	450	420	400	355	280
PEAK SPEED (***)	[rpm]	800	800	580	530	490	460	405	320
MAX. CONT. POWER (****)	[kW]	130	130	130	130	130	130	130	102
MAX. POWER	[kW]	160	160	160	160	160	160	160	130
MAX. CASE PRESSURE	[bar]	6	6	6	6	6	6	6	6
DRY WEIGHT	[kg]	92	92	92	92	92	92	92	92
TEMPERATURE RANGE (**)	[°C]	-30÷70	-30÷70	-30÷70	-30÷70	-30÷70	-30÷70	-30÷70	-30÷70

- (*) The standard distributor (D40) is shown. Please refer to distributors section (pag. 174-175) for different distributor interfaces.

- (**) Please refer to the hydraulic fluid recommendations (pag. 10-11).

- (***) Do not exceed maximum power (see pag. 13).

- (****) For motor operation with a continuous duty cycle at maximum continuous power the flushing is usually required. For more information please contact our technical department.

SHAFTS

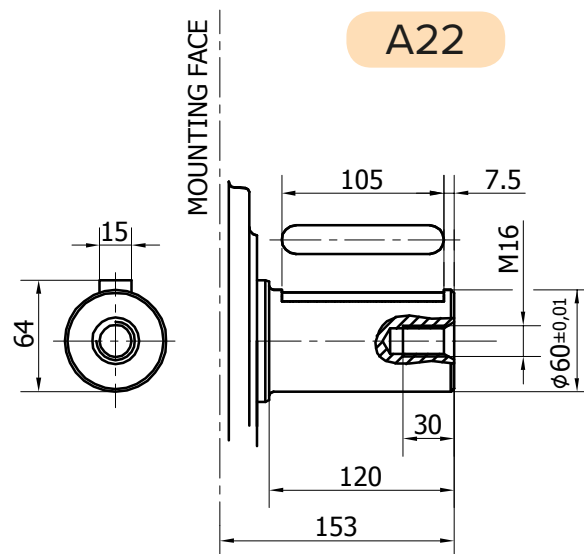
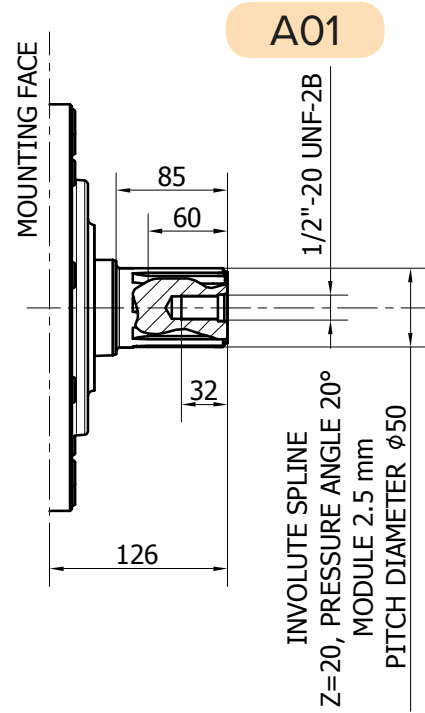
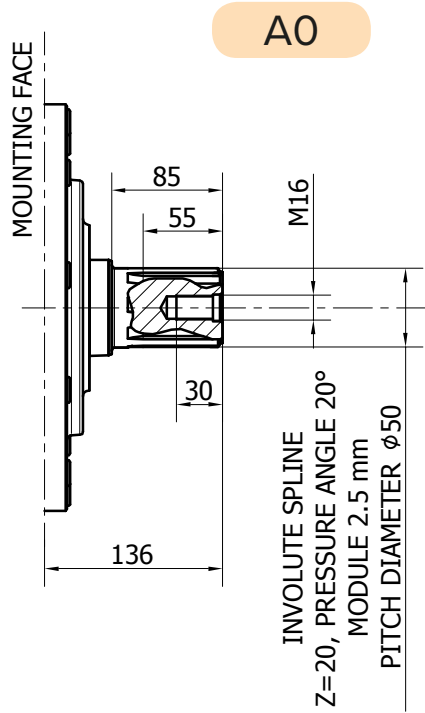

R8D H4 - PERFORMANCE CURVES

R8D 500 H4

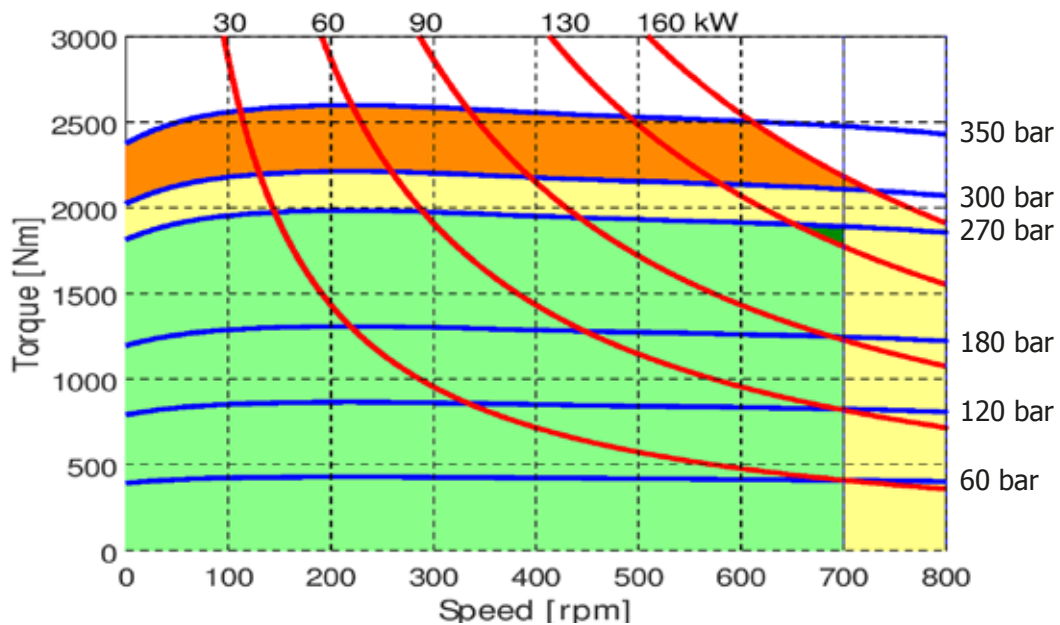

R8D 600 H4

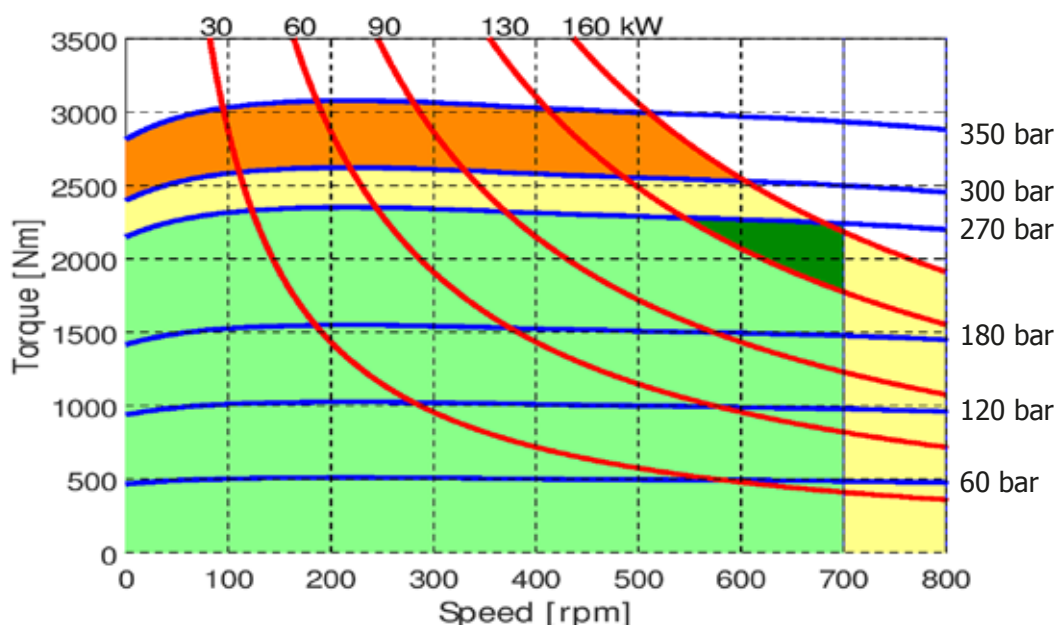

- Continuous operation
- Continuous operation with flushing or intermittent operation (see below for intermittent operation)
- Intermittent operation: permitted for a 15% of duty cycle, for 3 minutes maximum period
- Peak operation: permitted for very short periods (3-5 seconds every 10-15 minutes)

The above diagrams are referring to the hydraulic motor working with a fluid in ideal conditions (viscosity at 40 cSt). In case the working temperature increases and viscosity reach values under the recommended values (see hydraulic fluid recommendations) flushing must be performed or ISO oil grade must be changed. The working temperature must not overcome 70 °C.

SHAFTS

R8D 700 H4

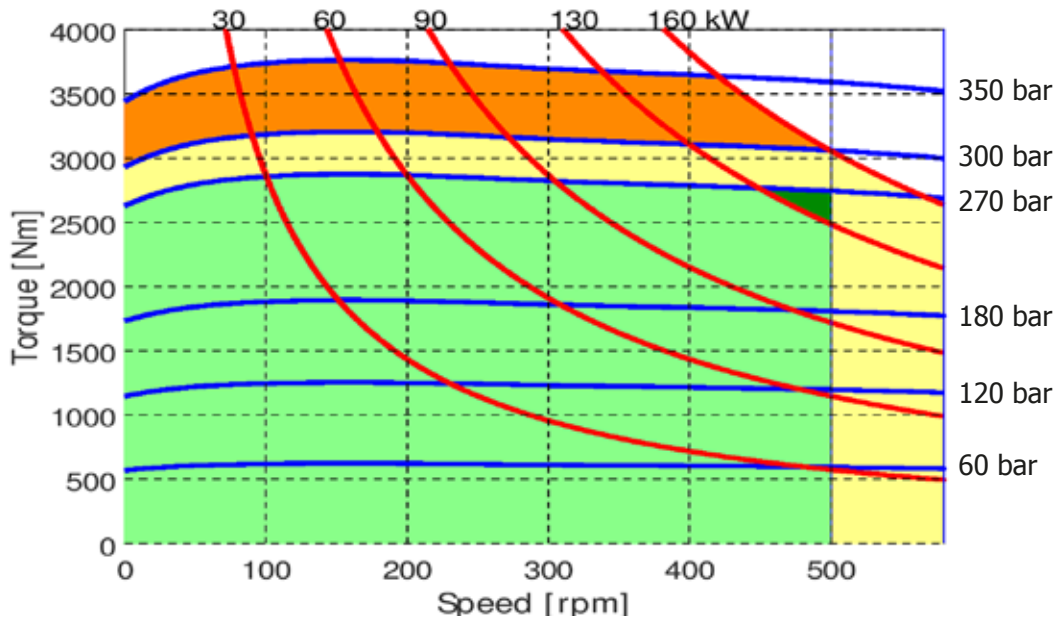

R8D 800 H4

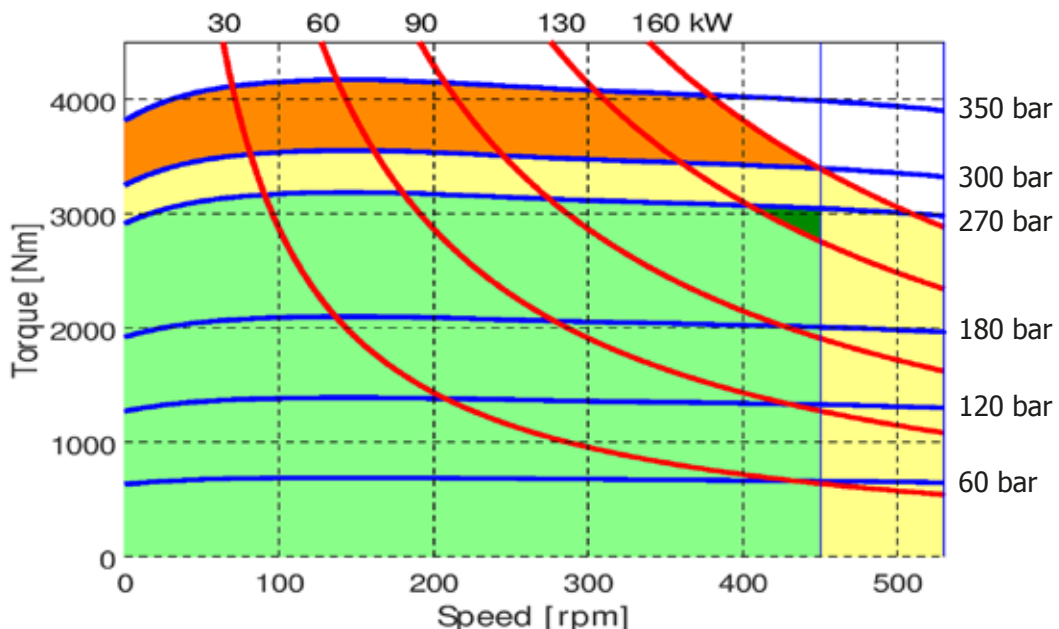

- Continuous operation
- Continuous operation with flushing or intermittent operation (see below for intermittent operation)
- Intermittent operation: permitted for a 15% of duty cycle, for 3 minutes maximum period
- Peak operation: permitted for very short periods (3-5 seconds every 10-15 minutes)

The above diagrams are referring to the hydraulic motor working with a fluid in ideal conditions (viscosity at 40 cSt). In case the working temperature increases and viscosity reach values under the recommended values (see hydraulic fluid recommendations) flushing must be performed or ISO oil grade must be changed. The working temperature must not overcome 70 °C.

R8D H4 - PERFORMANCE CURVES

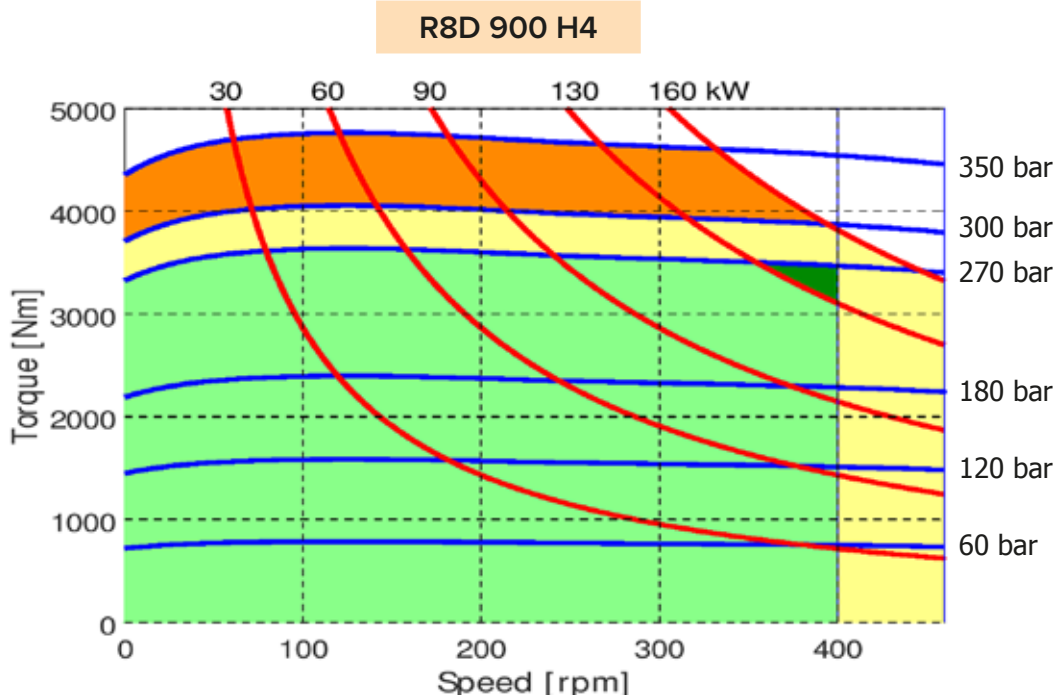
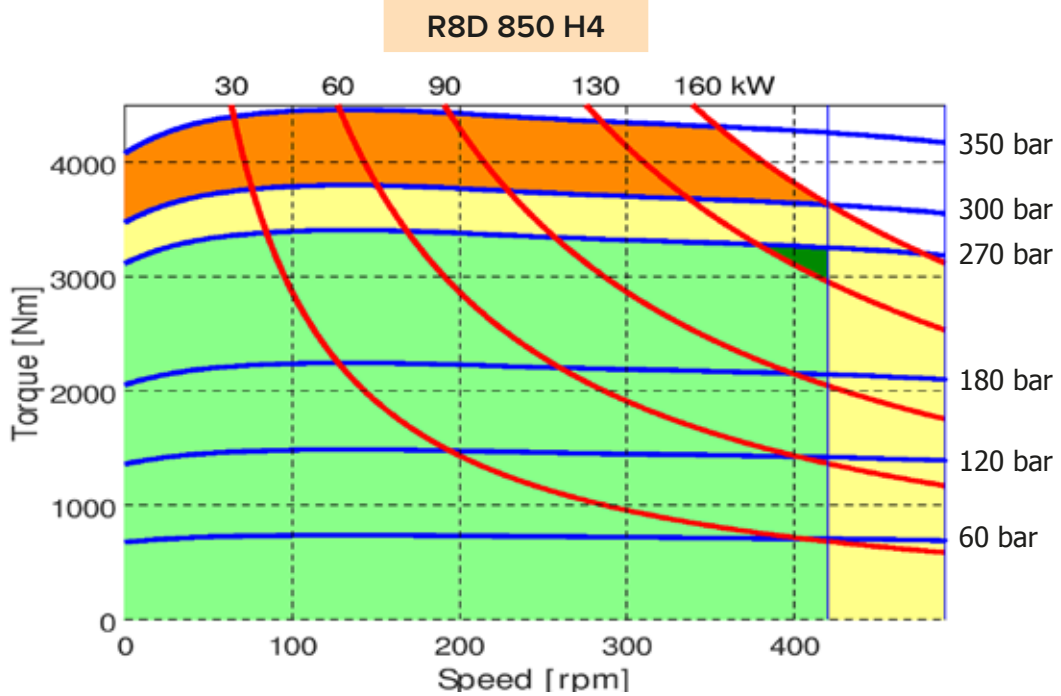

- Continuous operation
- Continuous operation with flushing or intermittent operation (see below for intermittent operation)
- Intermittent operation: permitted for a 15% of duty cycle, for 3 minutes maximum period
- Peak operation: permitted for very short periods (3-5 seconds every 10-15 minutes)

The above diagrams are referring to the hydraulic motor working with a fluid in ideal conditions (viscosity at 40 cSt). In case the working temperature increases and viscosity reach values under the recommended values (see hydraulic fluid recommendations) flushing must be performed or ISO oil grade must be changed. The working temperature must not overcome 70 °C.

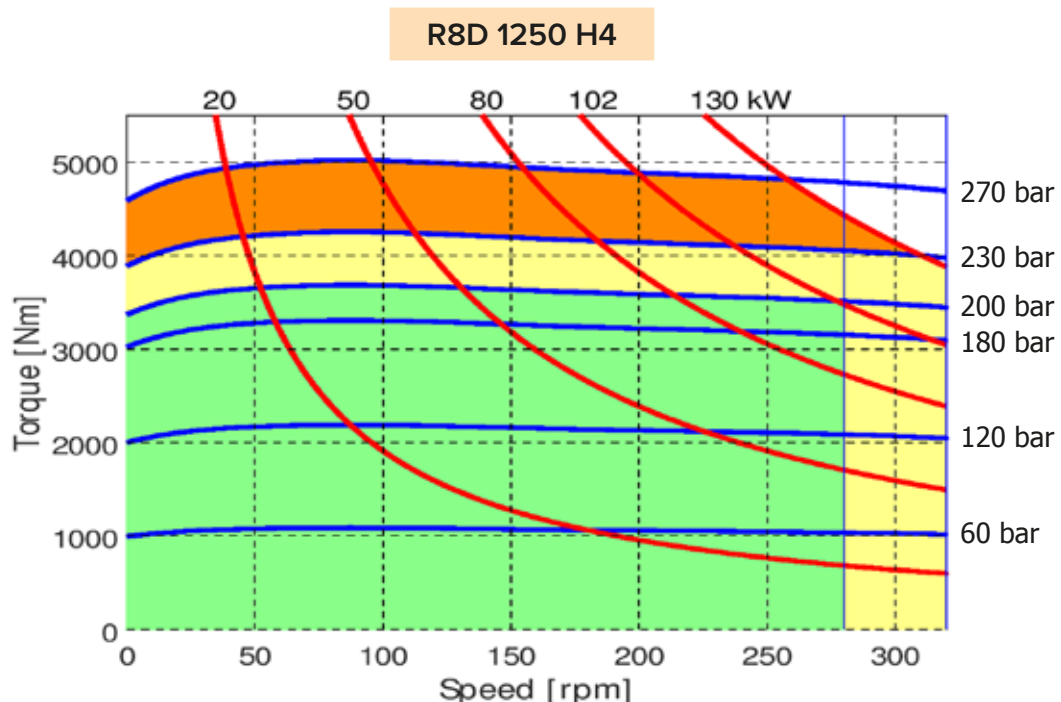
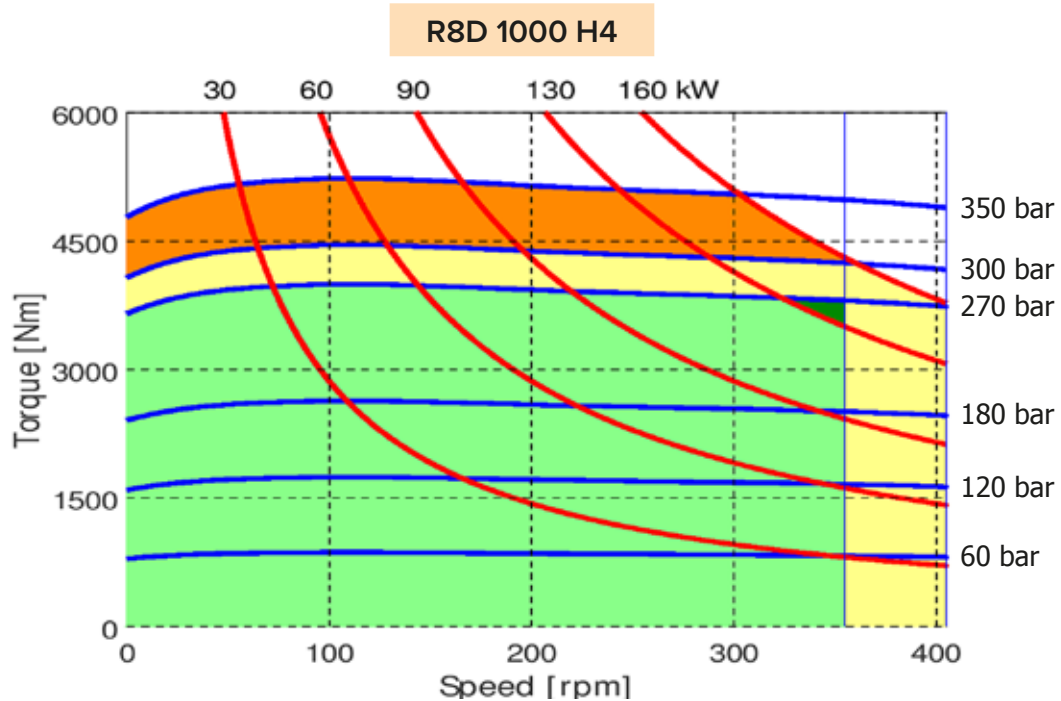

- Continuous operation
- Continuous operation with flushing or intermittent operation (see below for intermittent operation)
- Intermittent operation: permitted for a 15% of duty cycle, for 3 minutes maximum period
- Peak operation: permitted for very short periods (3-5 seconds every 10-15 minutes)

The above diagrams are referring to the hydraulic motor working with a fluid in ideal conditions (viscosity at 40 cSt). In case the working temperature increases and viscosity reach values under the recommended values (see hydraulic fluid recommendations) flushing must be performed or ISO oil grade must be changed. The working temperature must not overcome 70 °C.

R8D H4 - PERFORMANCE CURVES

CREEP SPEED - VOLUMETRIC EFFICIENCY

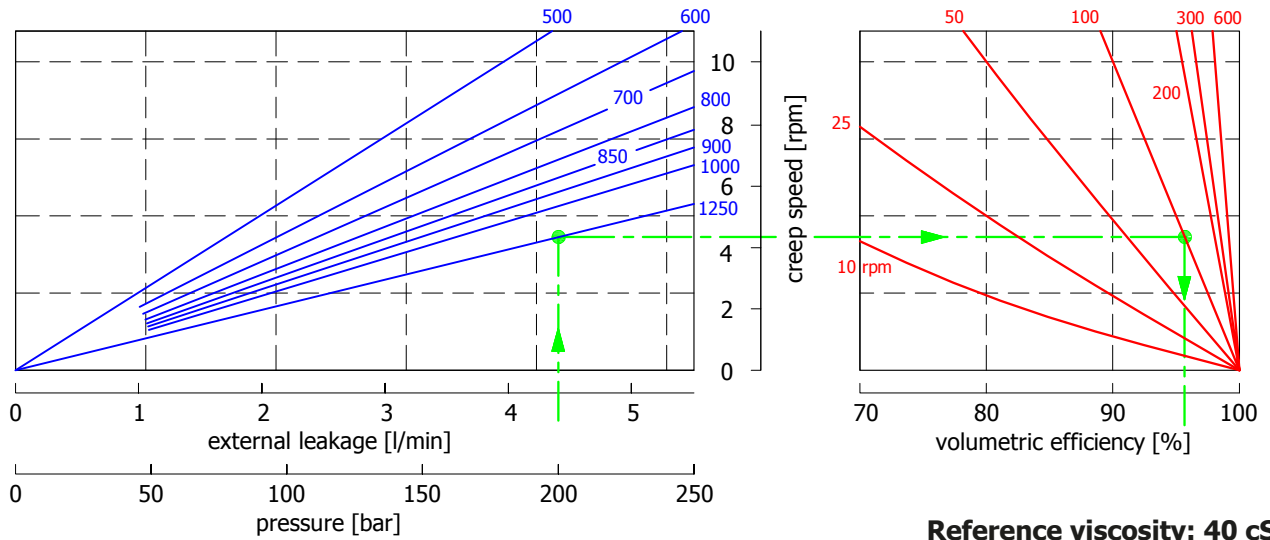

Reference viscosity: 40 cSt

Example:

We suppose (1250 cc): $p=200$ [bar], we obtain: external leakage 4,3 [l/min], shaft creep speed 4,2 [rpm].
 If we suppose (1250 cc): $p=200$ [bar] and $n=100$ [rpm] we obtain a volumetric efficiency of 96%;

BEARING LIFE

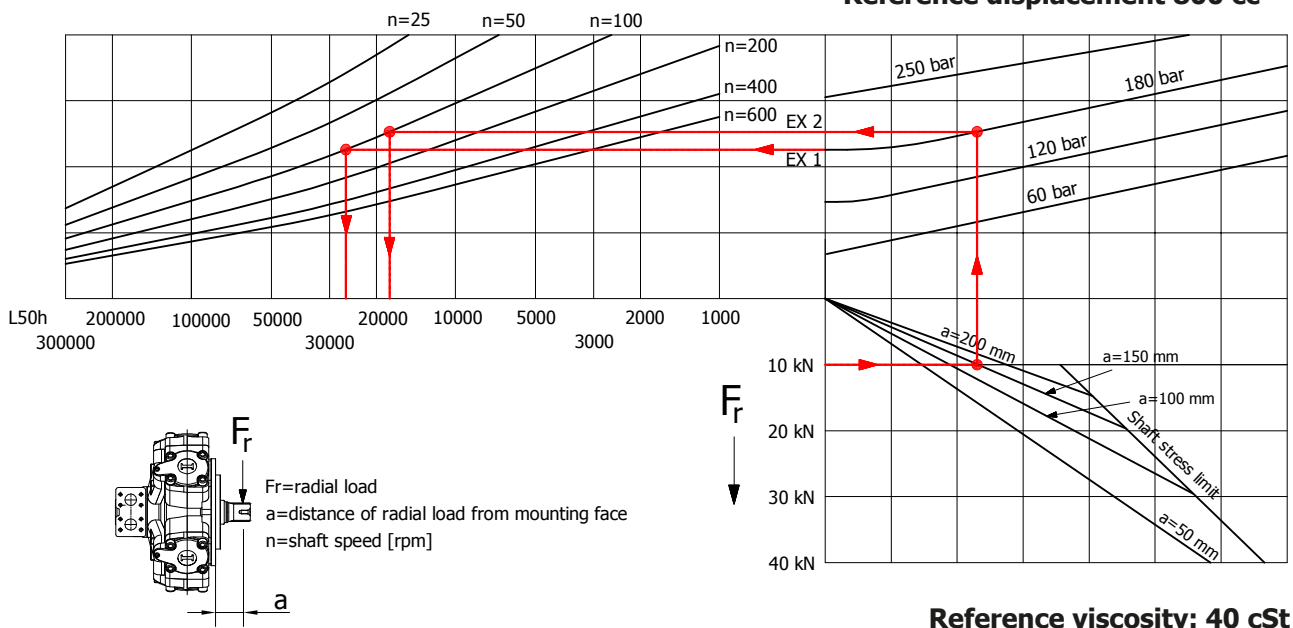

Reference displacement 800 cc

Reference viscosity: 40 cSt

Example:

We suppose (EX1): $p=180$ [bar], $n=100$ [rpm]; we obtain an average lifetime of 25000 [h].
 If we suppose (EX2): $F_r=10$ [kN], $a=150$ [mm], $n=100$ [rpm] and $p=180$ [bar] we obtain an average lifetime of 18000 [h].

R8D H4 - ORDERING CODE

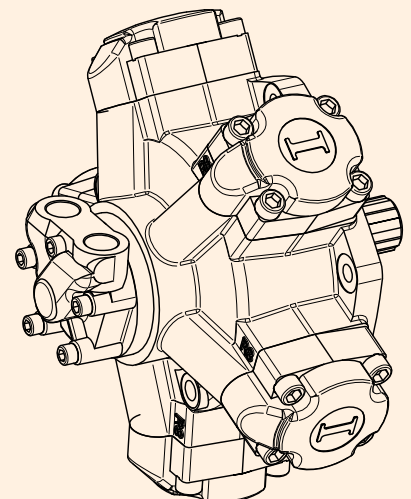
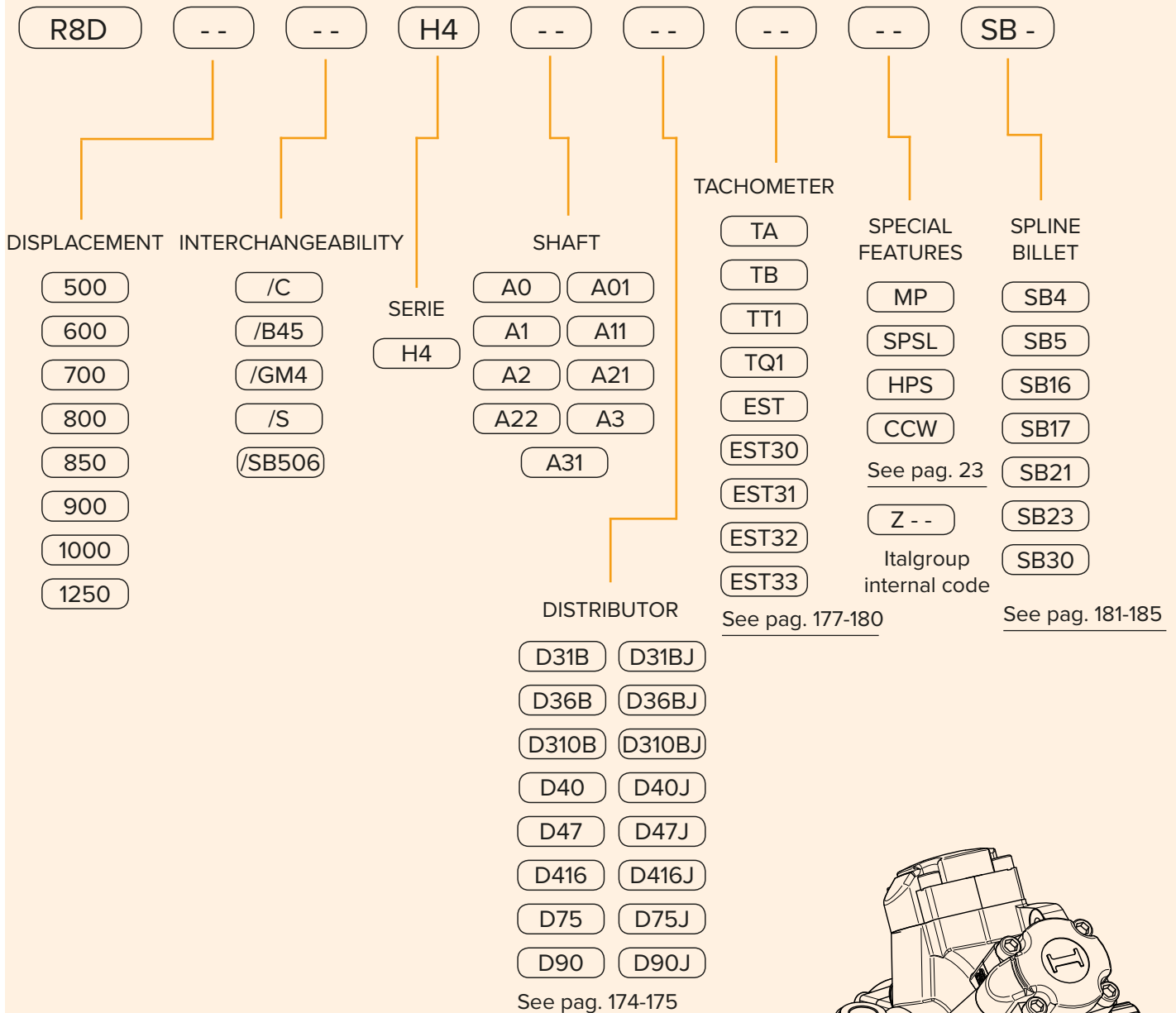

EXAMPLES:

- R8D 800 H4 A0 D40
- R8D 800/C H4 A0 D47
- R8D 1000/GM4 H4 A3 D47 CCW

R 8 D H 4 5

R8D H45	Pag. 72 - 73
R8D H45/C	Pag. 74 - 75
R8D H45 - PERFORMANCE CURVES	Pag. 76 - 78
R8D H45 - ORDERING CODE	Pag. 119

R8D H45

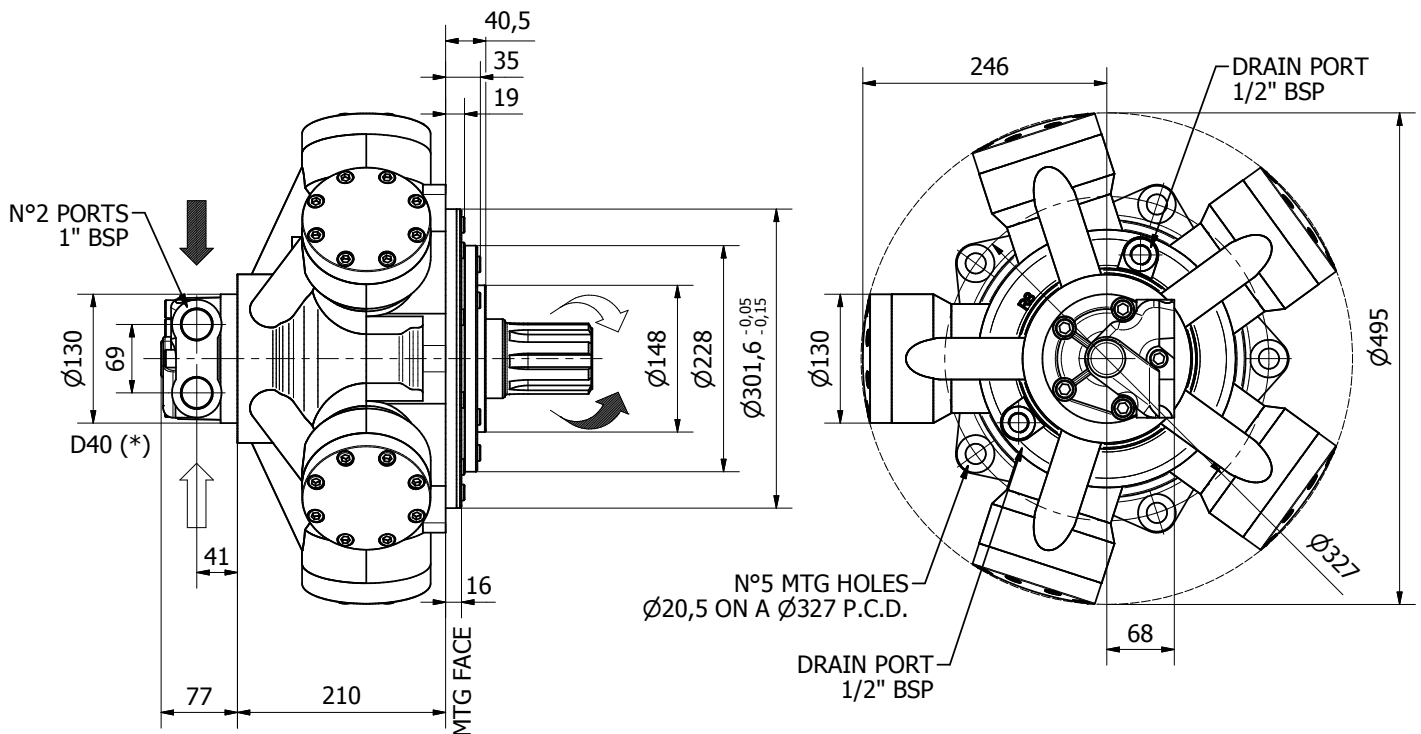

TECHNICAL DATA

		1100	1400
DISPLACEMENT	[cc]	1182	1376
SPECIFIC TORQUE	[Nm/bar]	18.8	21.9
MAX. CONT. PRESSURE	[bar]	270	270
HYDROSTATIC TEST PRESSURE	[bar]	420	420
MAX. CONT. SPEED	[rpm]	400	350
PEAK SPEED (**)	[rpm]	450	400
MAX. CONT. POWER (***)	[kW]	158	158
MAX. POWER	[kW]	190	190
MAX. CASE PRESSURE	[bar]	6	6
DRY WEIGHT	[kg]	120	120
TEMPERATURE RANGE (**)	[°C]	-30÷70	-30÷70

- (*) The standard distributor (D40) is shown. Please refer to distributors section (pag. 174-175) for different distributor interfaces.

- (**) Please refer to the hydraulic fluid recommendations (pag. 10-11).

- (***) Do not exceed maximum power (see pag. 13).

- (****) For motor operation with a continuous duty cycle at maximum continuous power the flushing is usually required. For more information please contact our technical department.

SHAFTS

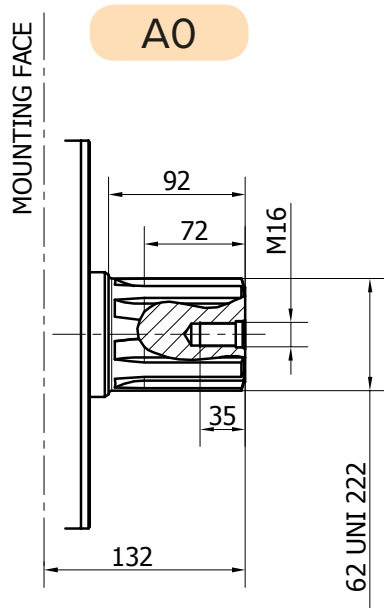

Available spline billet: SB6

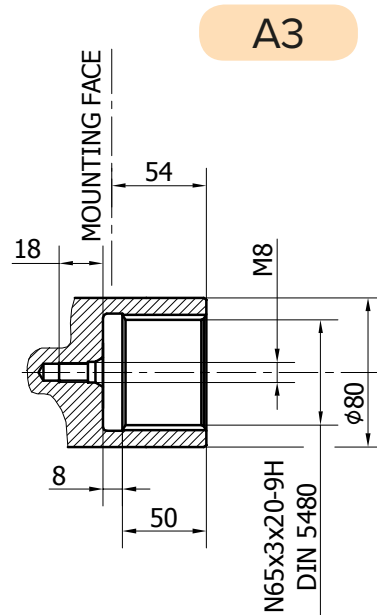

R8D H45/C

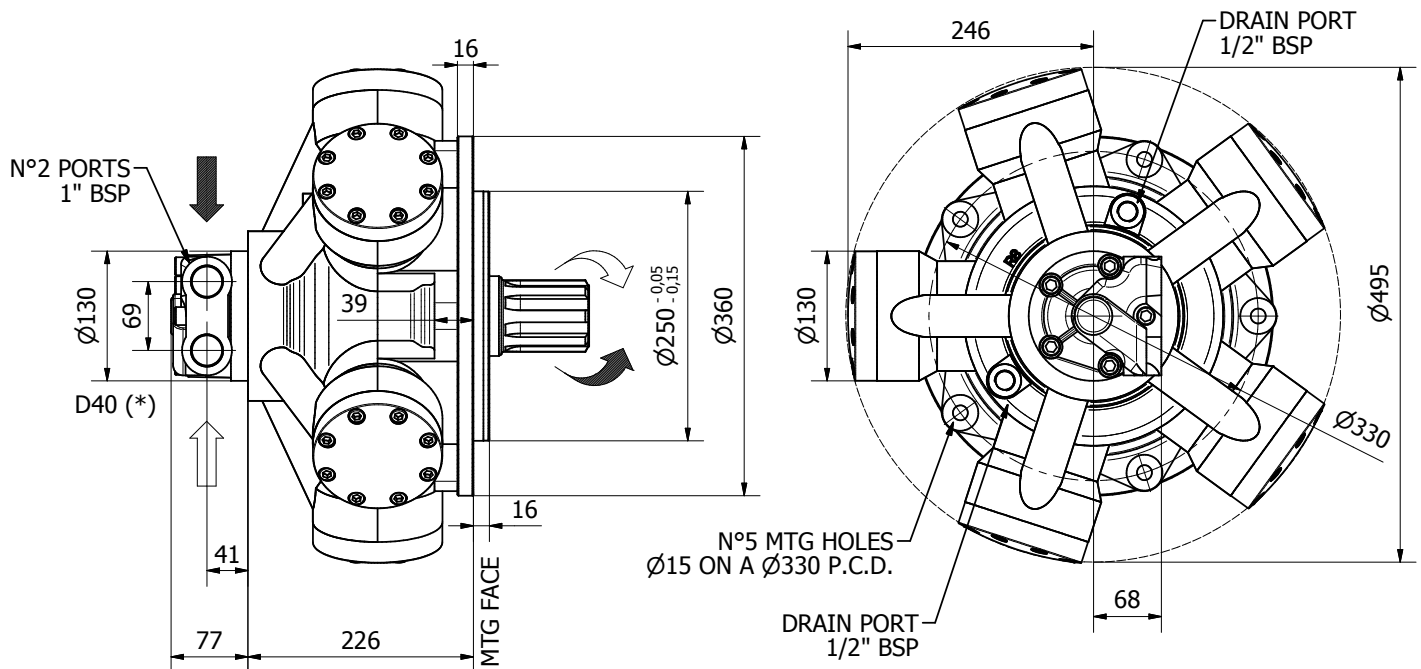

Available distributor flange: **FL4**

Refer to page 186-187
(distributor fitting D75)

TECHNICAL DATA

		1100	1400
DISPLACEMENT	[cc]	1182	1376
SPECIFIC TORQUE	[Nm/bar]	18.8	21.9
MAX. CONT. PRESSURE	[bar]	270	270
HYDROSTATIC TEST PRESSURE	[bar]	420	420
MAX. CONT. SPEED	[rpm]	400	350
PEAK SPEED (***)	[rpm]	450	400
MAX. CONT. POWER (****)	[kW]	158	158
MAX. POWER	[kW]	190	190
MAX. CASE PRESSURE	[bar]	6	6
DRY WEIGHT	[kg]	120	120
TEMPERATURE RANGE (**)	[°C]	-30÷70	-30÷70

- (*) The standard distributor (D40) is shown. Please refer to distributors section (pag. 174-175) for different distributor interfaces.

- (**) Please refer to the hydraulic fluid recommendations (pag. 10-11).

- (***) Do not exceed maximum power (see pag. 13).

- (****) For motor operation with a continuous duty cycle at maximum continuous power the flushing is usually required. For more information please contact our technical department.

SHAFTS

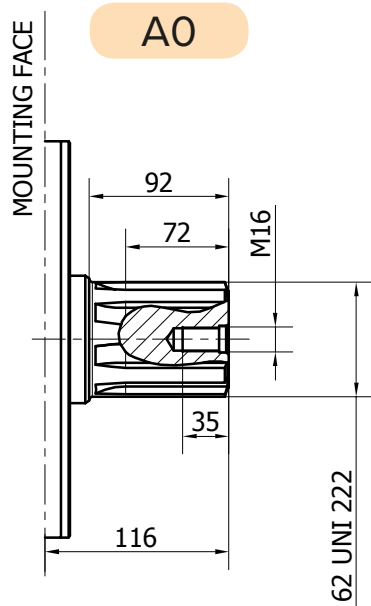

Available spline billet: SB6

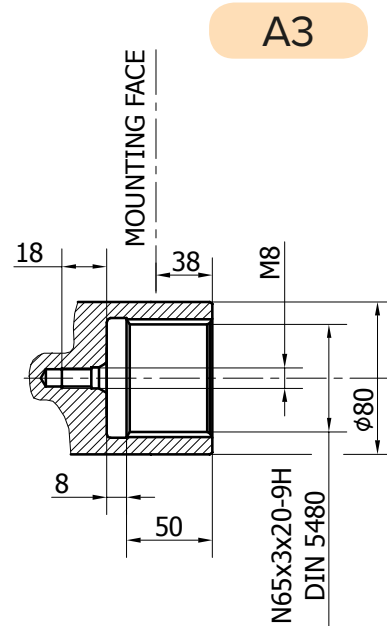

R8D H45 - PERFORMANCE CURVES

R8D 1100 H45

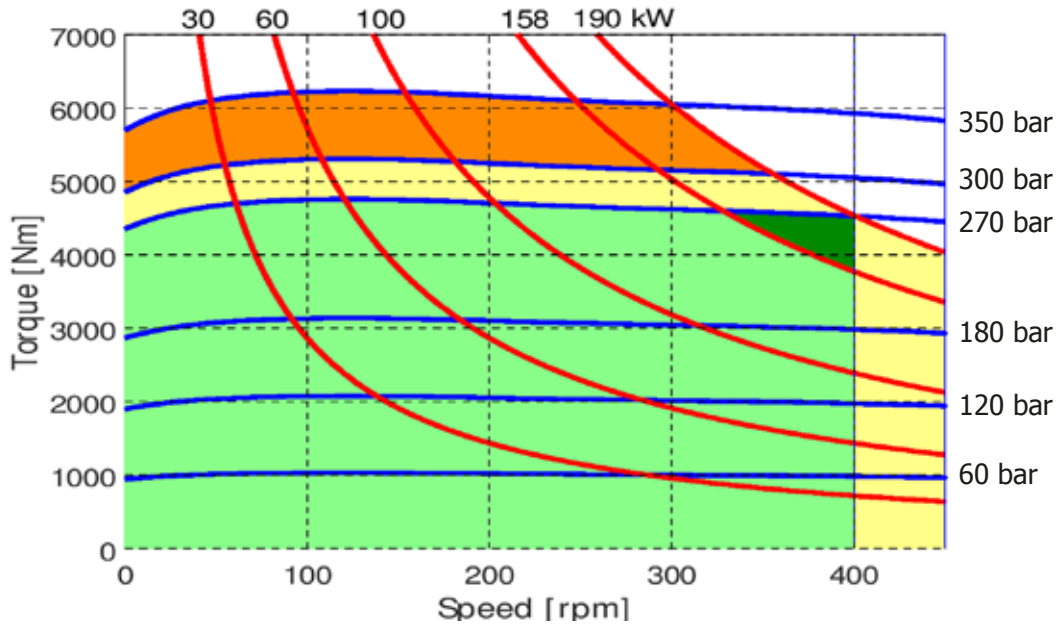

R8D 1400 H45

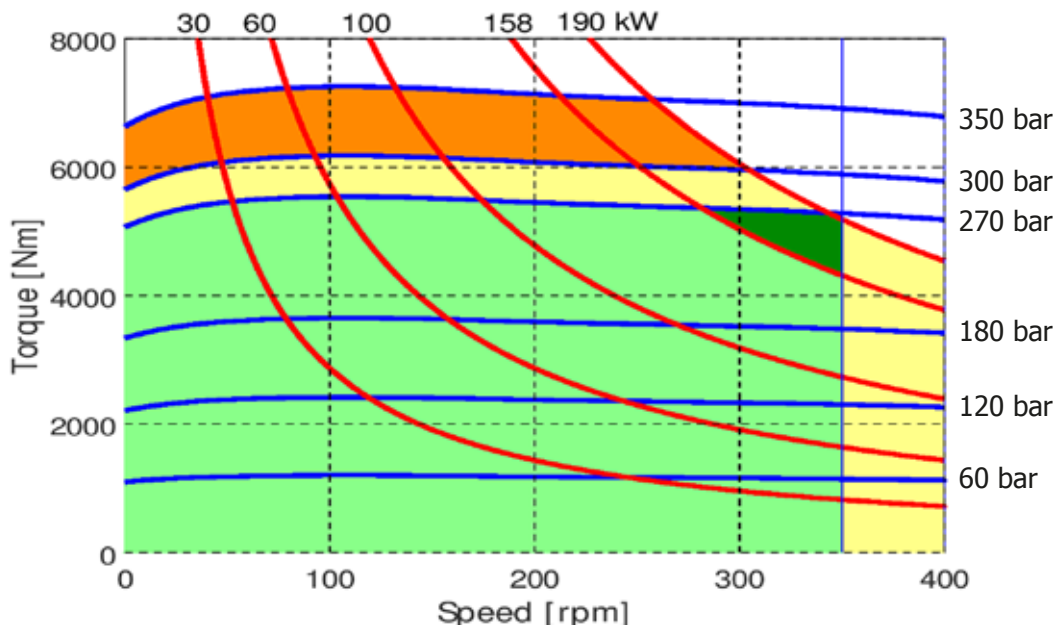

- Continuous operation
- Continuous operation with flushing or intermittent operation (see below for intermittent operation)
- Intermittent operation: permitted for a 15% of duty cycle, for 3 minutes maximum period
- Peak operation: permitted for very short periods (3-5 seconds every 10-15 minutes)

The above diagrams are referring to the hydraulic motor working with a fluid in ideal conditions (viscosity at 40 cSt). In case the working temperature increases and viscosity reach values under the recommended values (see hydraulic fluid recommendations) flushing must be performed or ISO oil grade must be changed. The working temperature must not overcome 70 °C.

CREEP SPEED - VOLUMETRIC EFFICIENCY

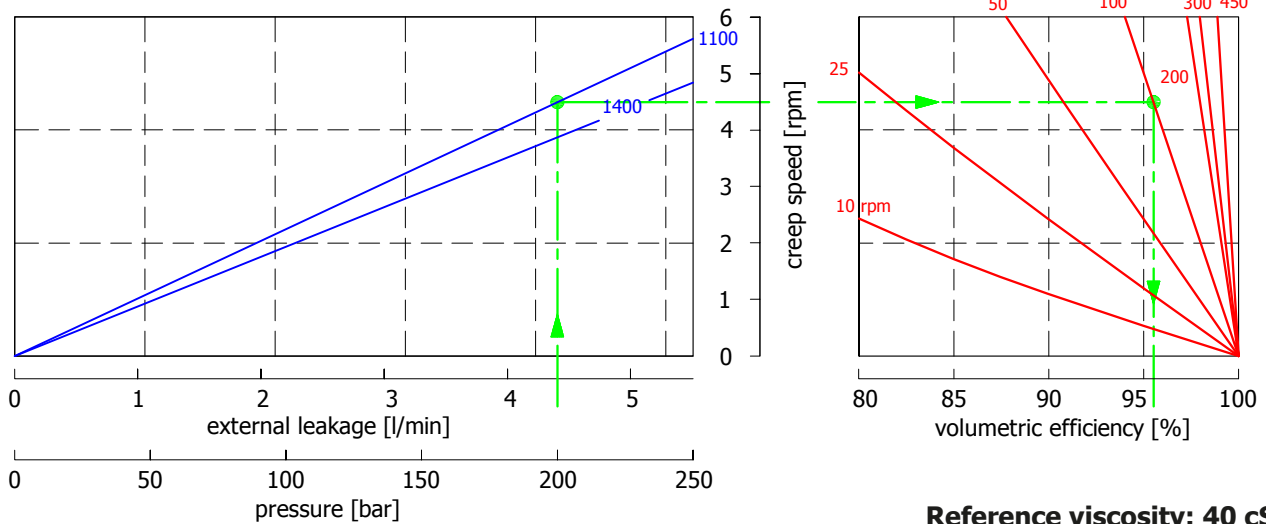

Reference viscosity: 40 cSt

Example:

We suppose (1100 cc): $p=200$ [bar], we obtain: external leakage 4,3 [l/min], shaft creep speed 4,5 [rpm].
 If we suppose (1100 cc): $p=200$ [bar] and $n=100$ [rpm] we obtain a volumetric efficiency of 95,5%;

BEARING LIFE

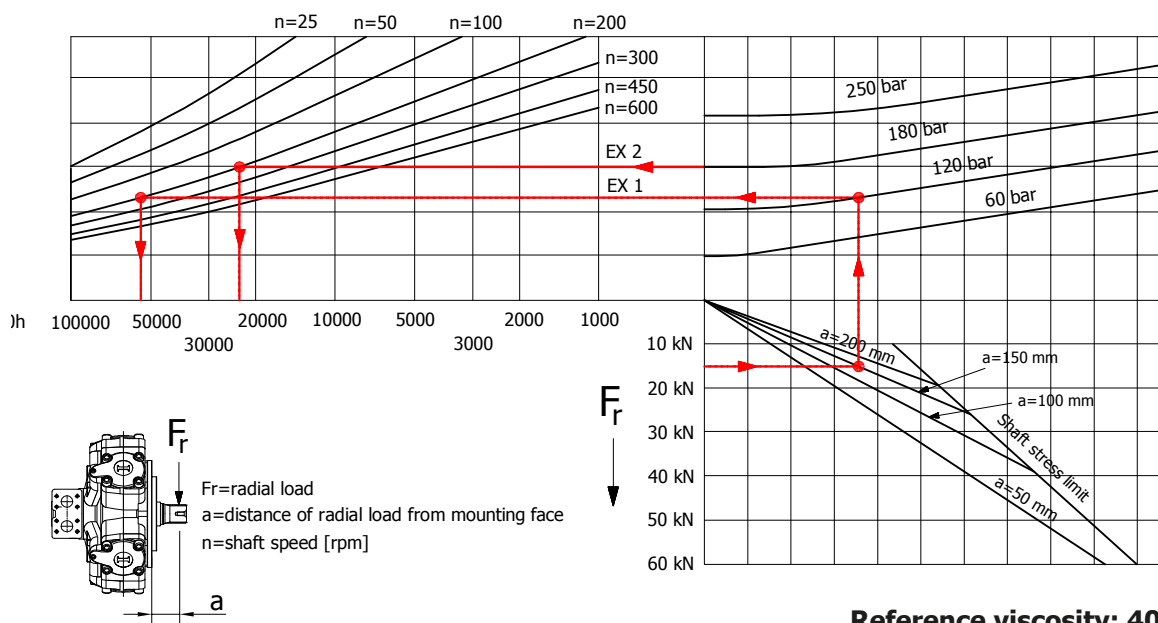

Reference viscosity: 40 cSt

Example:

We suppose (EX2): $p=180$ [bar], $n=200$ [rpm]; we obtain an average lifetime of 22000 [h].
 If we suppose (EX1): $F_r=15$ [kN], $a=150$ [mm], $n=200$ [rpm] and $p=120$ [bar] we obtain an average lifetime of 51000 [h].

R8D H45 - ORDERING CODE

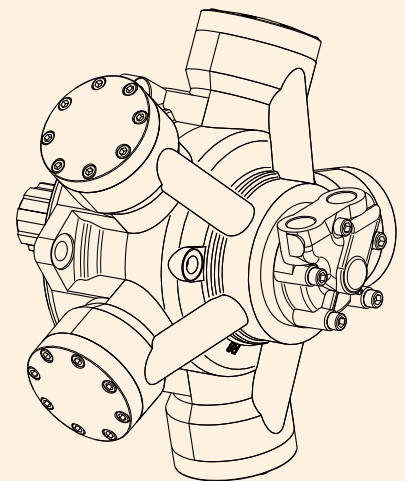
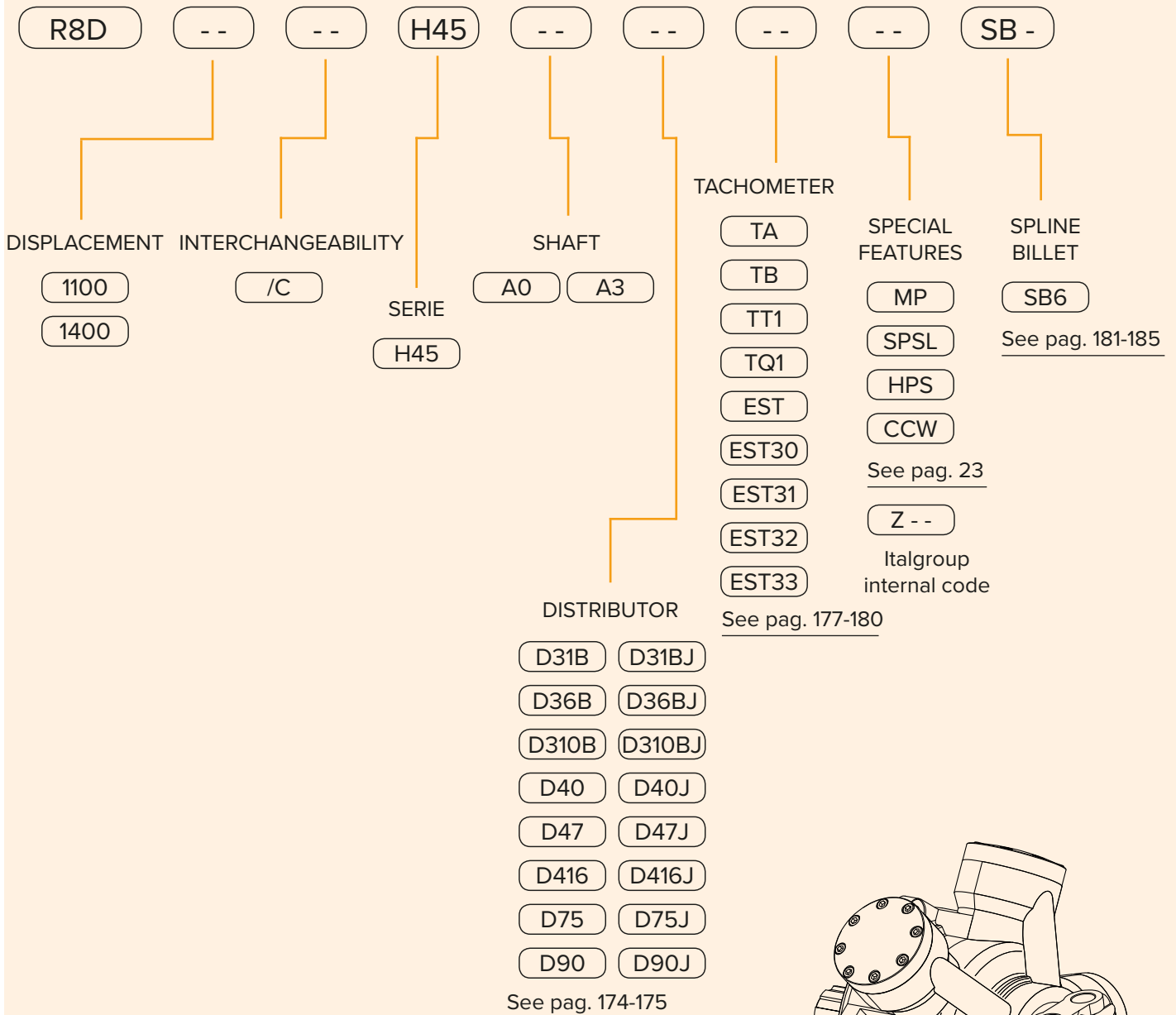

EXAMPLES:

R8D 1100 H45 A0 D75
 R8D 1100/C H45 A0 D47
 R8D 1400/C H45 A0 D75 SB6

R8D H5

R8D H5	Pag. 80 - 82
R8D H5/C1100	Pag. 84 - 85
R8D 1600-1800-2000-2200/C H5	Pag. 86 - 87
R8D 1000/B60-1400/B80-1600/B100 H5	Pag. 88 - 89
R8D H5/GM5 - R8D H5/S	Pag. 90 - 91
R8D H5/RM	Pag. 92 - 93
R8D H5 - PERFORMANCE CURVES	Pag. 94 - 98
R8D H5 - ORDERING CODE	Pag. 99

R8D H5

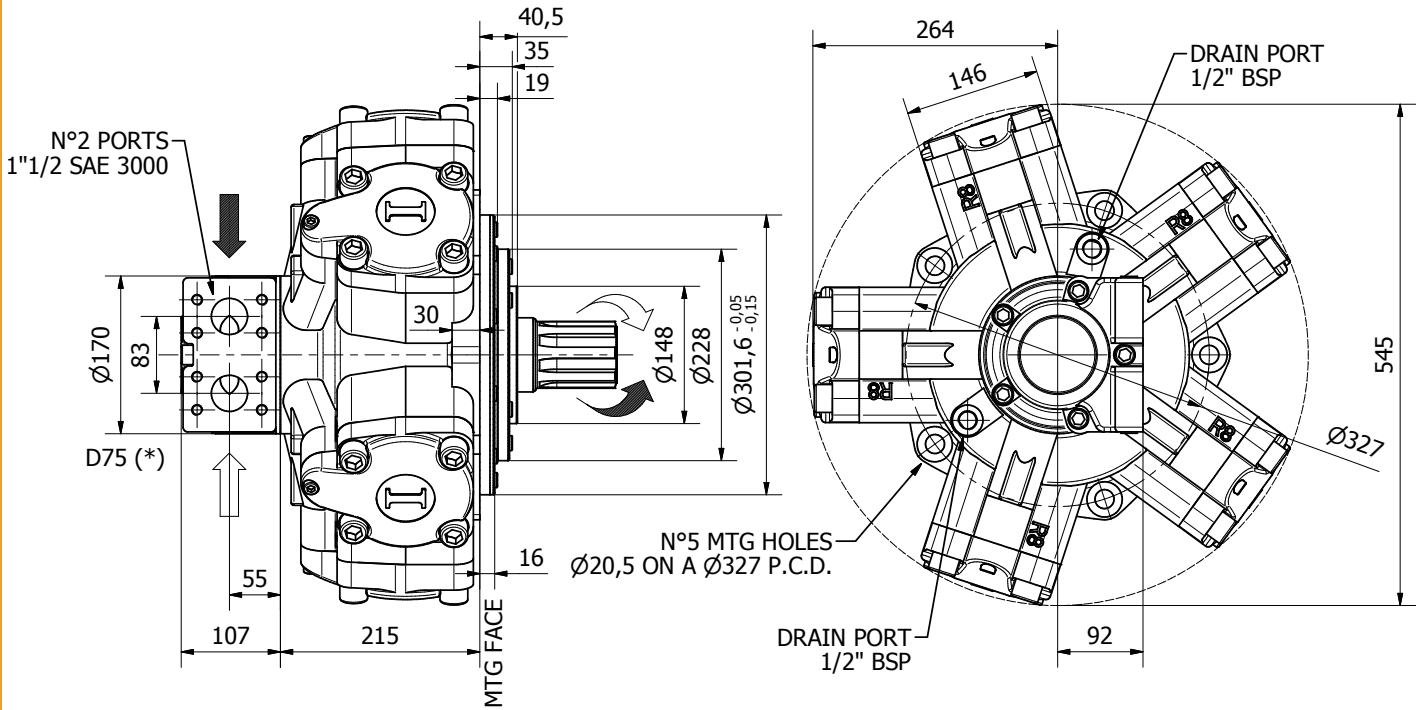

Available distributor flanges: **FL5** **FL6**

For S03 and S04, refer to page 186-187 (distributor fitting D75)

TECHNICAL DATA

		900	1000	1200	1400	1500	1600	1800	2000
DISPLACEMENT	[cc]	941	1094	1231	1376	1528	1648	1815	2034
SPECIFIC TORQUE	[Nm/bar]	15	17.4	19.6	21.9	24.3	26.2	28.9	32.4
MAX. CONT. PRESSURE	[bar]	270	270	270	270	270	270	250	190
HYDROSTATIC TEST PRESSURE	[bar]	420	420	420	420	420	420	420	420
MAX. CONT. SPEED	[rpm]	550	500	450	410	390	370	340	280
PEAK SPEED (***)	[rpm]	600	550	510	470	450	425	390	310
MAX. CONT. POWER (****)	[kW]	178	178	178	178	178	178	178	140
MAX. POWER	[kW]	210	210	210	210	210	210	210	160
MAX. CASE PRESSURE	[bar]	6	6	6	6	6	6	6	6
DRY WEIGHT	[kg]	173	173	173	173	173	173	173	173
TEMPERATURE RANGE (**)	[°C]	-30÷70	-30÷70	-30÷70	-30÷70	-30÷70	-30÷70	-30÷70	-30÷70

- (*) The standard distributor (D75) is shown. Please refer to distributors section (pag. 174-175) for different distributor interfaces.

- (**) Please refer to the hydraulic fluid recommendations (pag. 10-11).

- (***) Do not exceed maximum power (see pag. 13).

- (****) For motor operation with a continuous duty cycle at maximum continuous power the flushing is usually required. For more information please contact our technical department.

SHAFTS

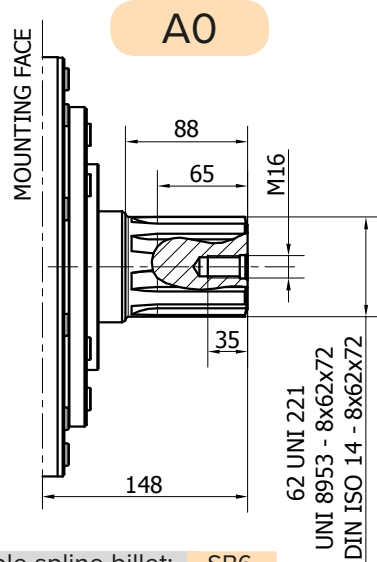

Available spline billet: SB6

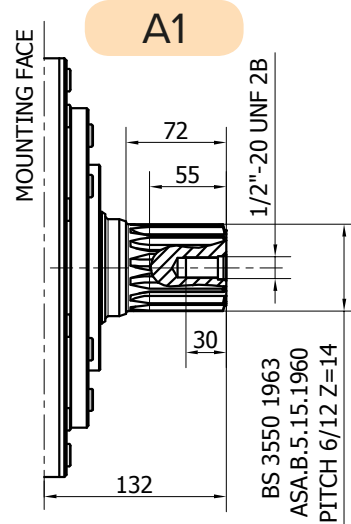

Available spline billet: SB7

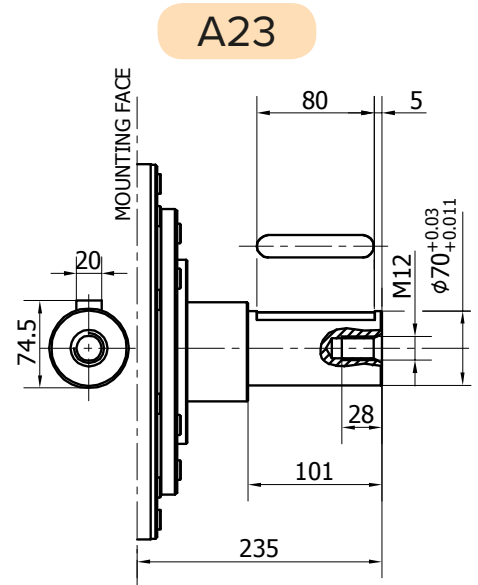
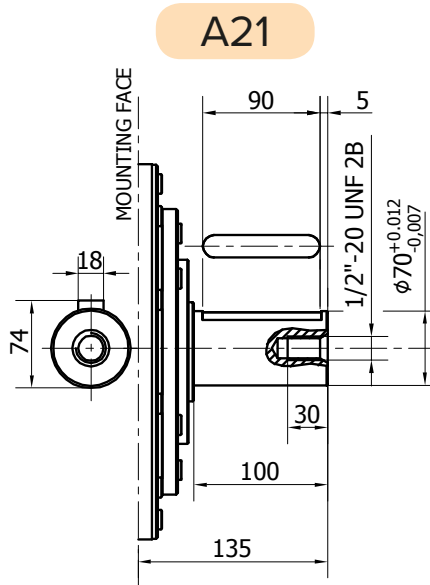
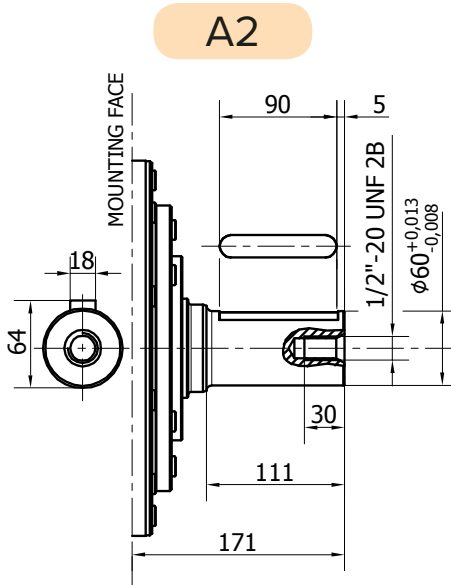

R8D H5

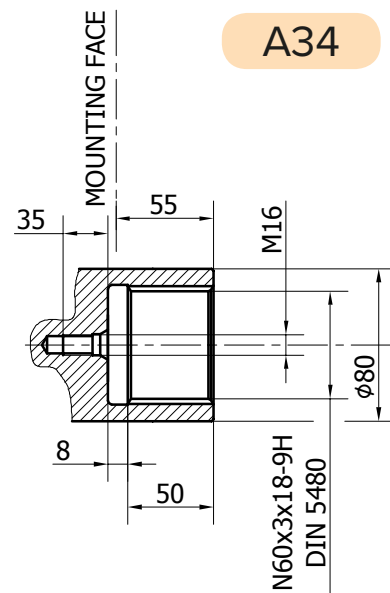
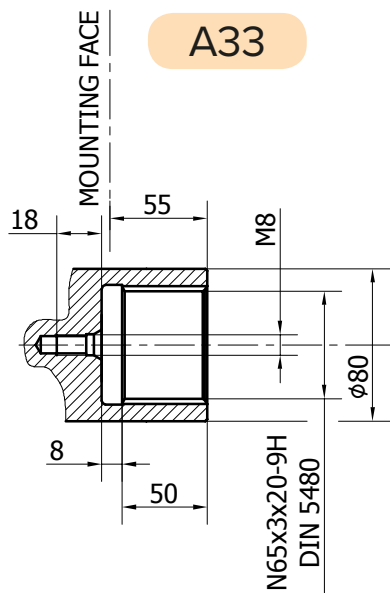
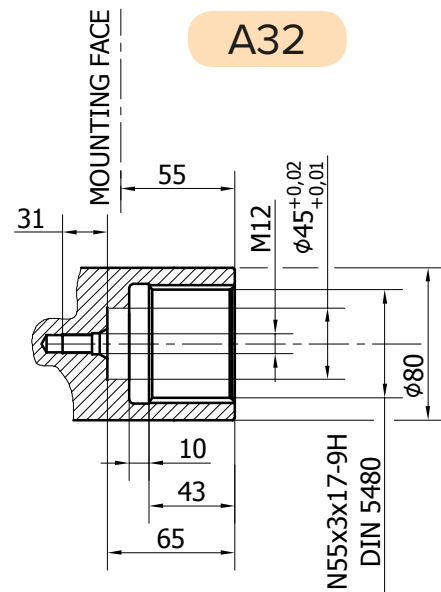
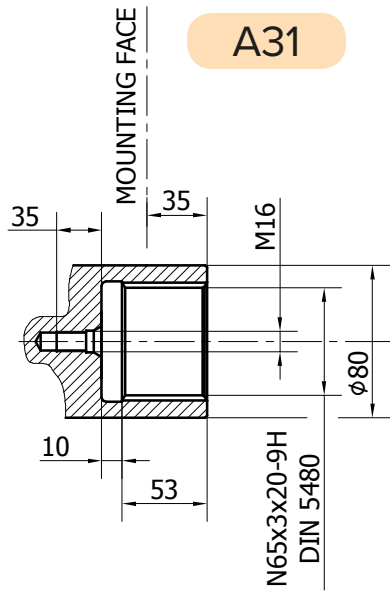

SHAFTS

R8D H5/C1100

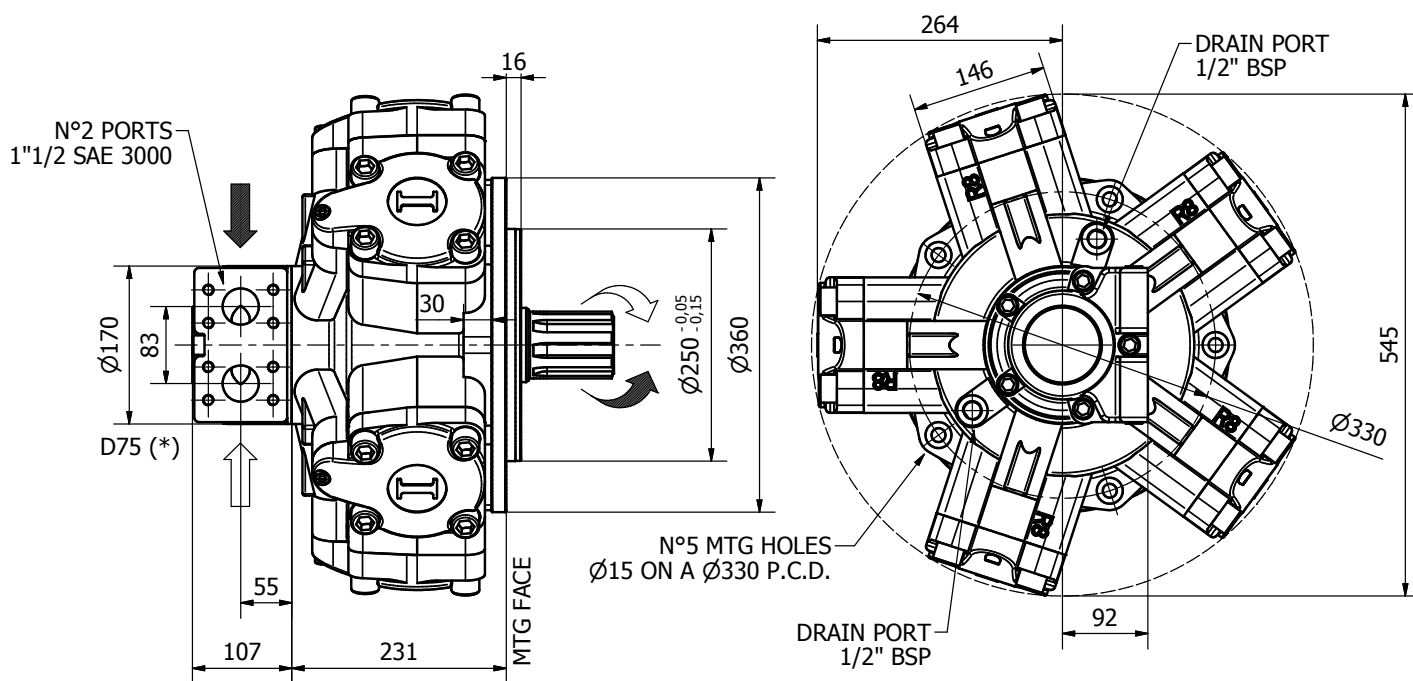

Available distributor flange: **FL4**

Refer to page 186-187
(distributor fitting D75)

TECHNICAL DATA

		900	1000	1200	1400	1500	1600	1800	2000
DISPLACEMENT	[cc]	941	1094	1231	1376	1528	1648	1815	2034
SPECIFIC TORQUE	[Nm/bar]	15	17.4	19.6	21.9	24.3	26.2	28.9	32.4
MAX. CONT. PRESSURE	[bar]	270	270	270	270	270	270	250	190
HYDROSTATIC TEST PRESSURE	[bar]	420	420	420	420	420	420	420	420
MAX. CONT. SPEED	[rpm]	550	500	450	410	390	370	340	280
PEAK SPEED (***)	[rpm]	600	550	510	470	450	425	390	310
MAX. CONT. POWER (****)	[kW]	178	178	178	178	178	178	178	140
MAX. POWER	[kW]	210	210	210	210	210	210	210	160
MAX. CASE PRESSURE	[bar]	6	6	6	6	6	6	6	6
DRY WEIGHT	[kg]	173	173	173	173	173	173	173	173
TEMPERATURE RANGE (**)	[°C]	-30÷70	-30÷70	-30÷70	-30÷70	-30÷70	-30÷70	-30÷70	-30÷70

- (*) The standard distributor (D75) is shown. Please refer to distributors section (pag. 174-175) for different distributor interfaces.

- (**) Please refer to the hydraulic fluid recommendations (pag. 10-11).

- (***) Do not exceed maximum power (see pag. 13).

- (****) For motor operation with a continuous duty cycle at maximum continuous power the flushing is usually required. For more information please contact our technical department.

SHAFTS

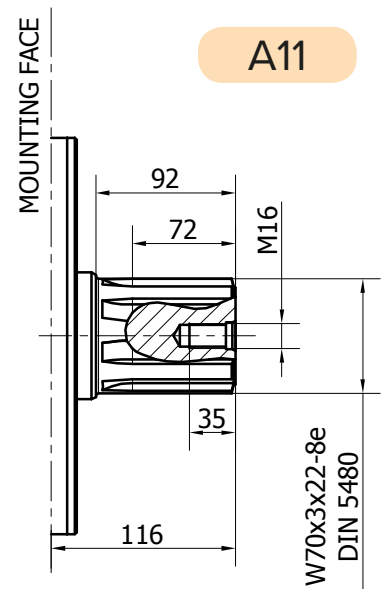
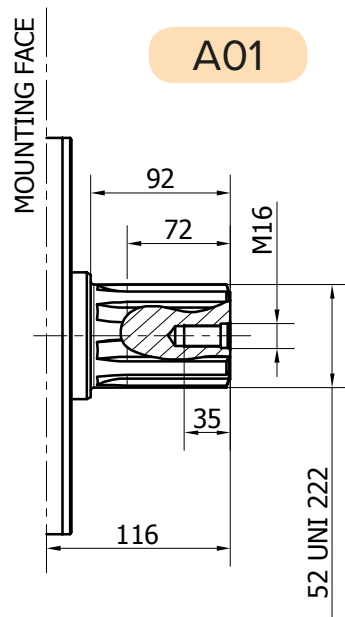
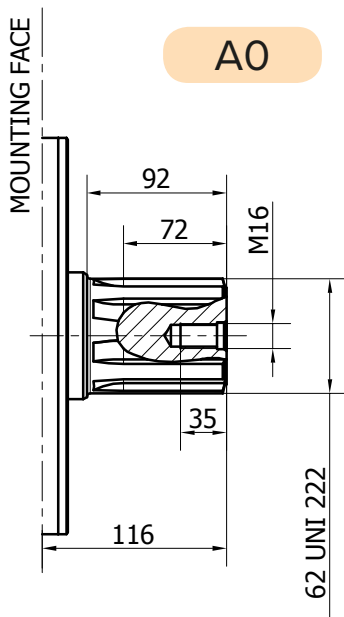

Available spline billet: SB6

Available spline billet: SB16

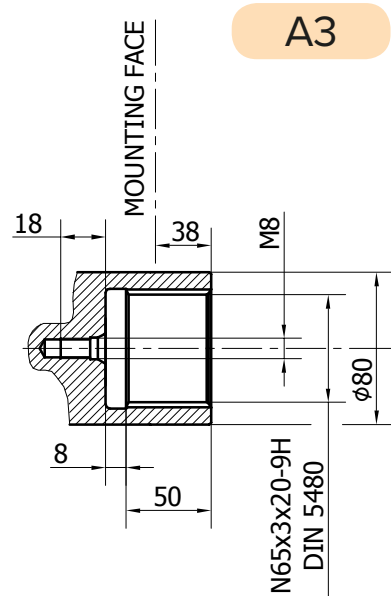
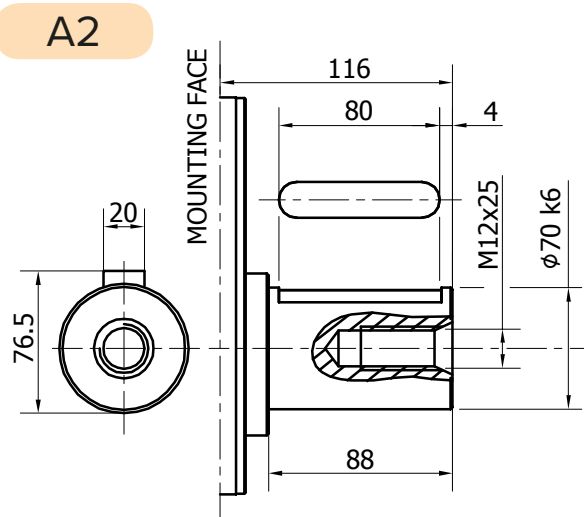

R8D 1600-1800-2000/C H5

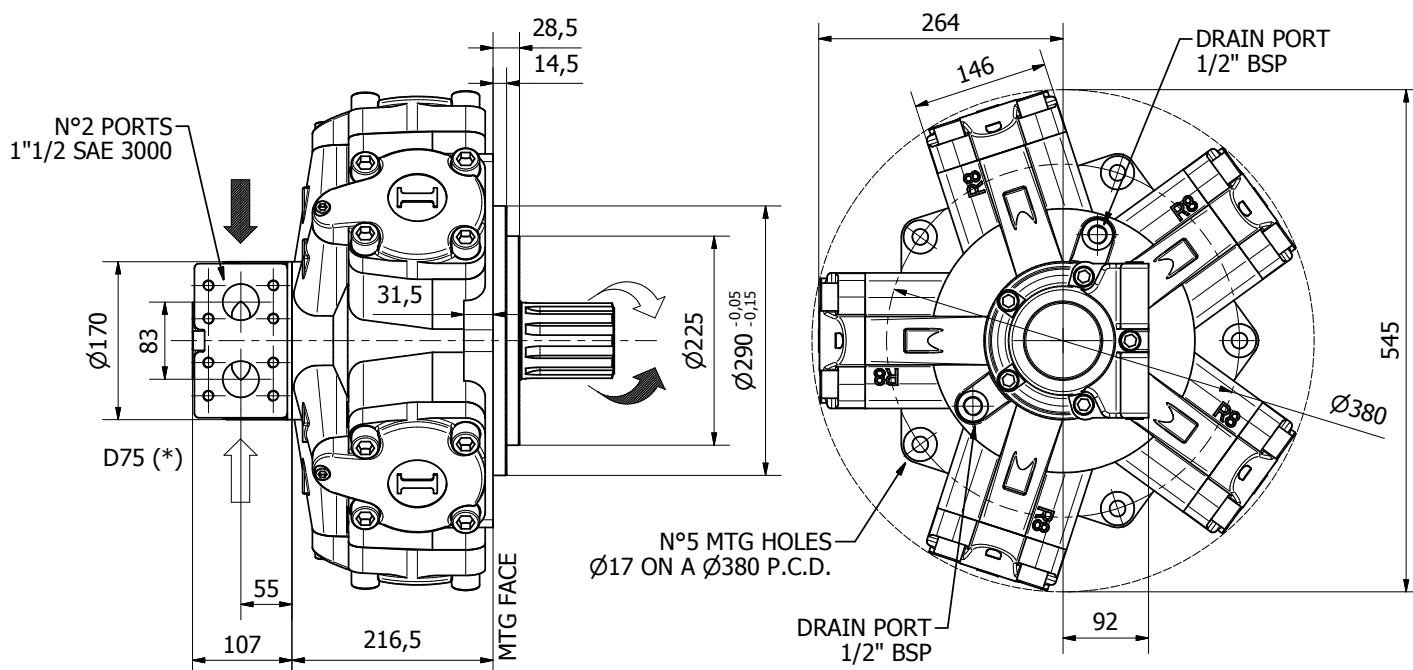

Available distributor flange: **FL4**

Refer to page 186-187
(distributor fitting D75)

TECHNICAL DATA

		1600	1800	2000
DISPLACEMENT	[cc]	1648	1815	2034
SPECIFIC TORQUE	[Nm/bar]	26.2	28.9	32.4
MAX. CONT. PRESSURE	[bar]	270	250	190
HYDROSTATIC TEST PRESSURE	[bar]	420	420	420
MAX. CONT. SPEED	[rpm]	370	340	280
PEAK SPEED (***)	[rpm]	425	390	310
MAX. CONT. POWER (****)	[kW]	178	178	140
MAX. POWER	[kW]	210	210	160
MAX. CASE PRESSURE	[bar]	6	6	6
DRY WEIGHT	[kg]	173	173	173
TEMPERATURE RANGE (**)	[°C]	-30÷70	-30÷70	-30÷70

- (*) The standard distributor (D75) is shown. Please refer to distributors section (pag. 174-175) for different distributor interfaces.

- (**) Please refer to the hydraulic fluid recommendations (pag. 10-11).

- (***) Do not exceed maximum power (see pag. 13).

- (****) For motor operation with a continuous duty cycle at maximum continuous power the flushing is usually required. For more information please contact our technical department.

SHAFTS

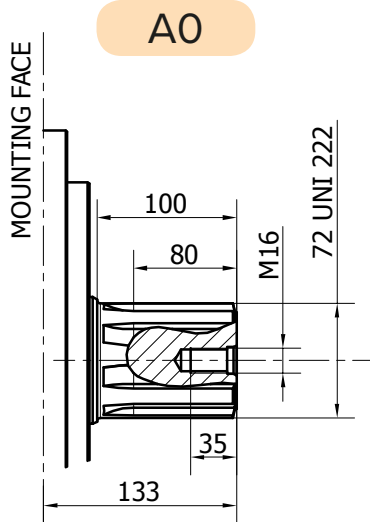

Available spline billet: **SB8**

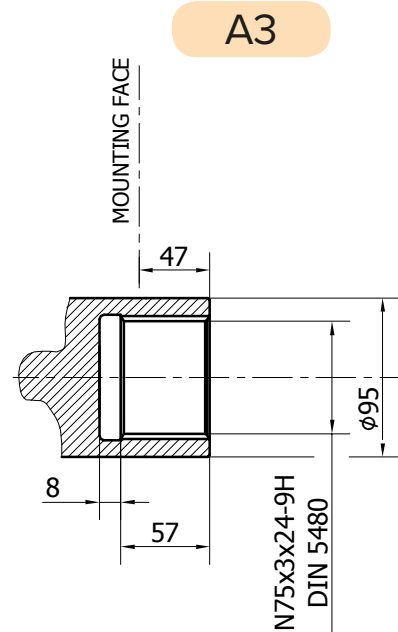
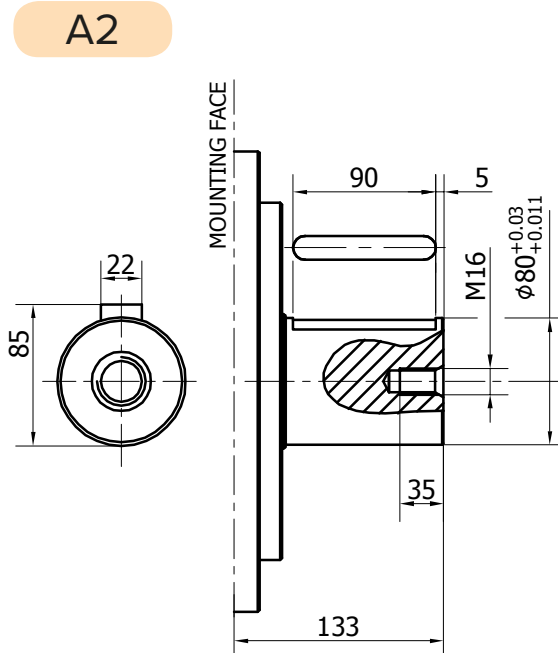
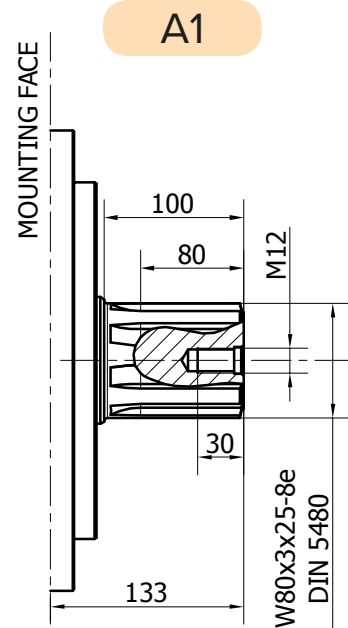

R8D 1000/B60-1400/B80-1600/B100

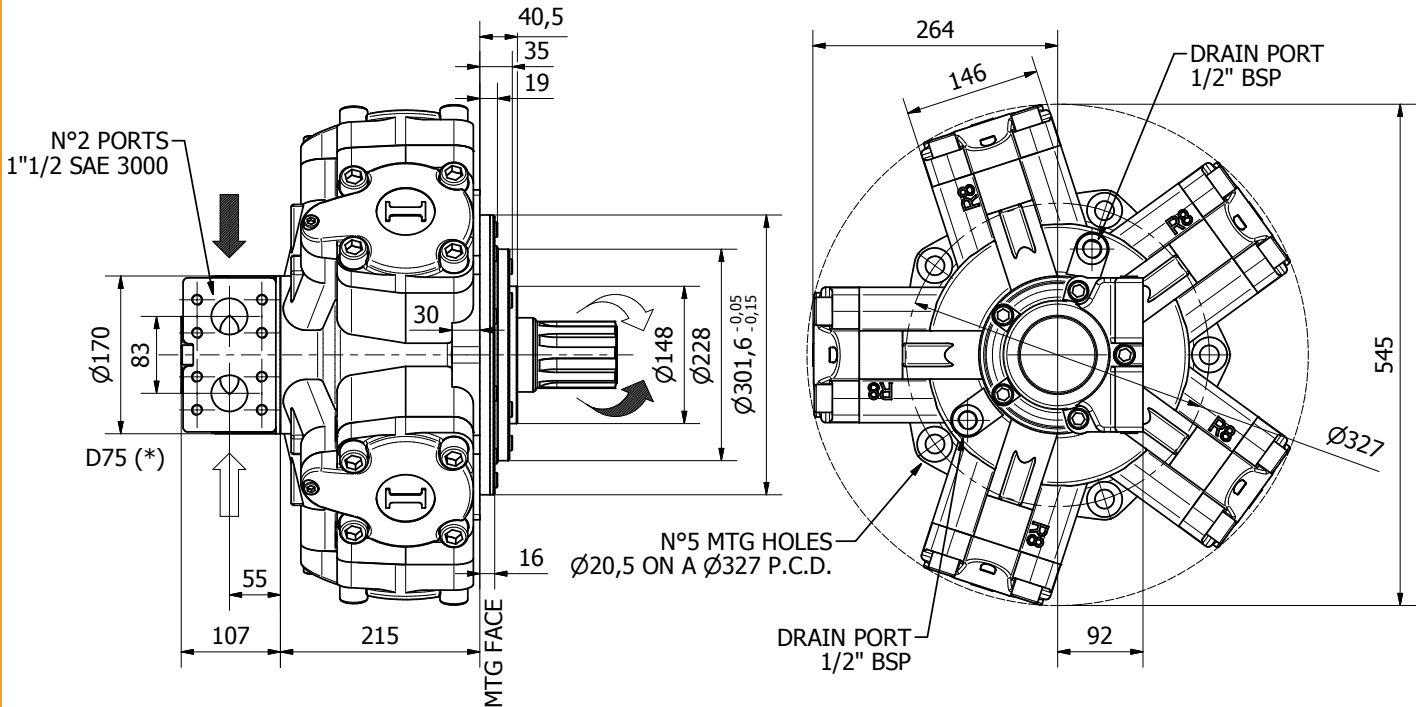

Available distributor flanges: **FL5** **FL6**

For S03 and S04, refer to page
186-187 (distributor fitting D75)

TECHNICAL DATA

		1000	1400	1600
DISPLACEMENT	[cc]	1094	1376	1648
SPECIFIC TORQUE	[Nm/bar]	17.4	21.9	26.2
MAX. CONT. PRESSURE	[bar]	270	270	270
HYDROSTATIC TEST PRES- SURE	[bar]	420	420	420
MAX. CONT. SPEED	[rpm]	500	410	370
PEAK SPEED (**)	[rpm]	550	470	425
MAX. CONT. POWER (***)	[kW]	178	178	178
MAX. POWER	[kW]	210	210	210
MAX. CASE PRESSURE	[bar]	6	6	6
DRY WEIGHT	[kg]	173	173	173
TEMPERATURE RANGE (**)	[°C]	-30÷70	-30÷70	-30÷70

- (*) The standard distributor (D75) is shown. Please refer to distributors section (pag. 174-175) for different distributor interfaces.

- (**) Please refer to the hydraulic fluid recommendations (pag. 10-11).

- (***) Do not exceed maximum power (see pag. 13).

- (****) For motor operation with a continuous duty cycle at maximum continuous power the flushing is usually required. For more information please contact our technical department.

SHAFTS

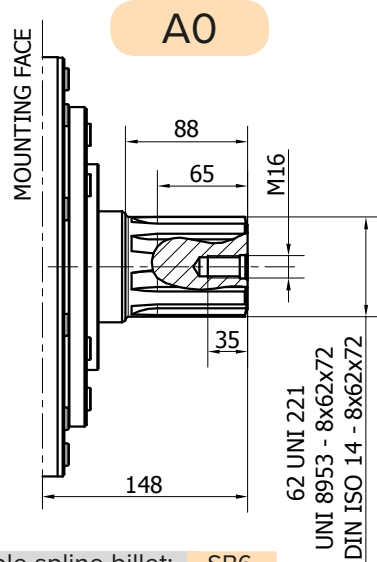

Available spline billet: **SB6**

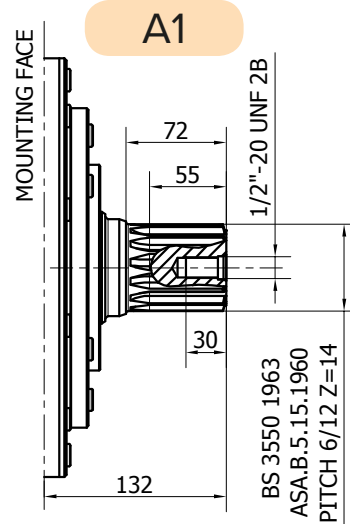

Available spline billet: **SB7**

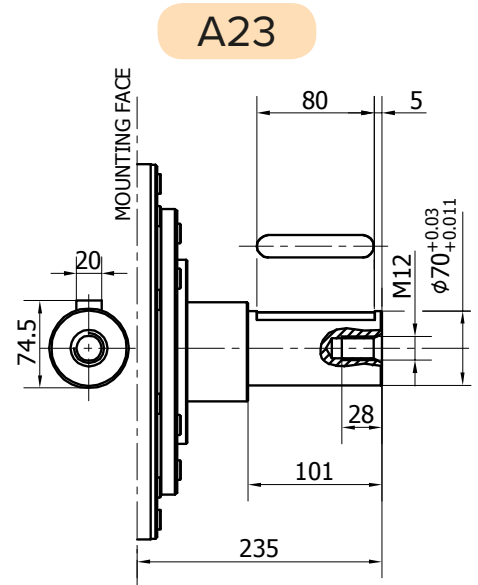
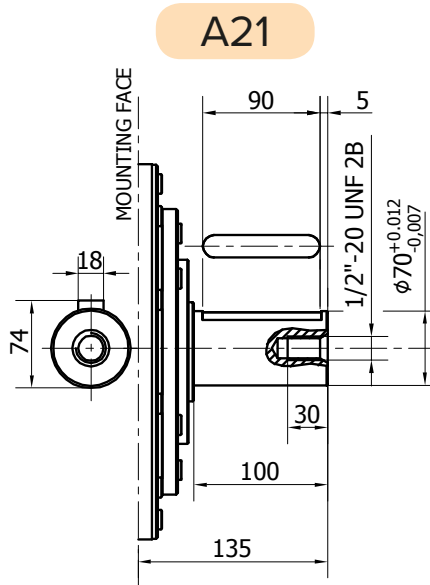
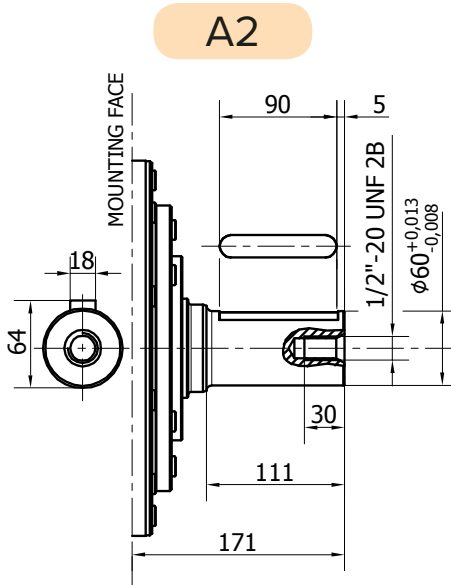

R8D H5/GM5 - R8D H5/S

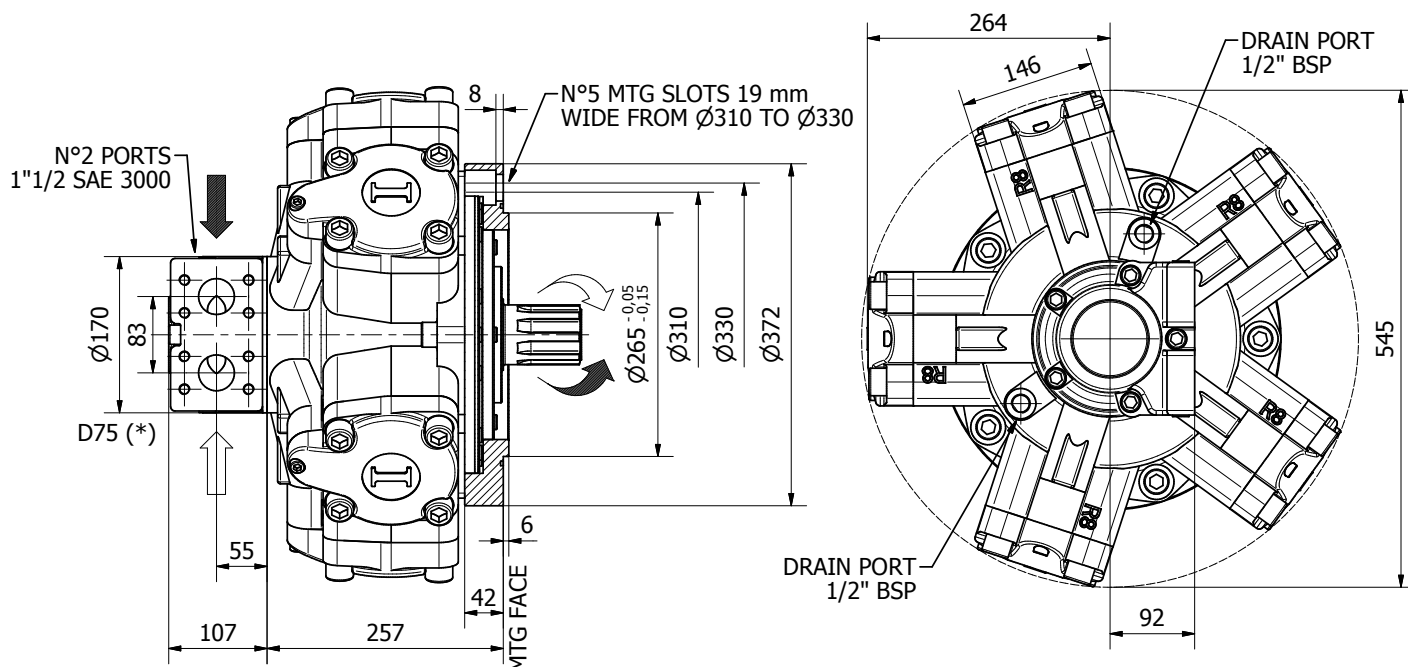

TECHNICAL DATA

		900	1000	1200	1400	1500	1600	1800	2000
DISPLACEMENT	[cc]	941	1094	1231	1376	1528	1648	1815	2034
SPECIFIC TORQUE	[Nm/bar]	15	17.4	19.6	21.9	24.3	26.2	28.9	32.4
MAX. CONT. PRESSURE	[bar]	270	270	270	270	270	270	250	190
HYDROSTATIC TEST PRESSURE	[bar]	420	420	420	420	420	420	420	420
MAX. CONT. SPEED	[rpm]	550	500	450	410	390	370	340	280
PEAK SPEED (***)	[rpm]	600	550	510	470	450	425	390	310
MAX. CONT. POWER (****)	[kW]	178	178	178	178	178	178	178	140
MAX. POWER	[kW]	210	210	210	210	210	210	210	160
MAX. CASE PRESSURE	[bar]	6	6	6	6	6	6	6	6
DRY WEIGHT	[kg]	173	173	173	173	173	173	173	173
TEMPERATURE RANGE (**)	[°C]	-30÷70	-30÷70	-30÷70	-30÷70	-30÷70	-30÷70	-30÷70	-30÷70

- (*) The standard distributor (D75) is shown. Please refer to distributors section (pag. 174-175) for different distributor interfaces.

- (**) Please refer to the hydraulic fluid recommendations (pag. 10-11).

- (***) Do not exceed maximum power (see pag. 13).

- (****) For motor operation with a continuous duty cycle at maximum continuous power the flushing is usually required. For more information please contact our technical department.

SHAFTS

A0

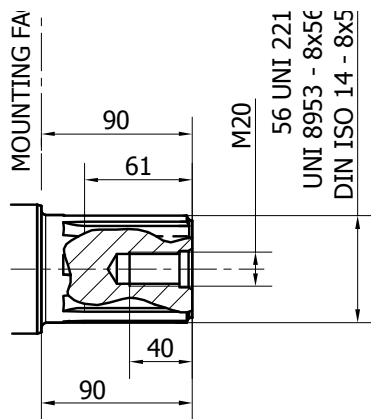

Available spline billet: SB17

A1

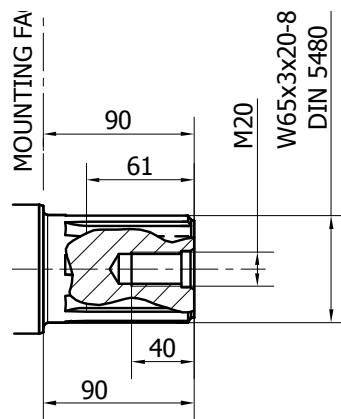

Available spline billet: SB23

A2

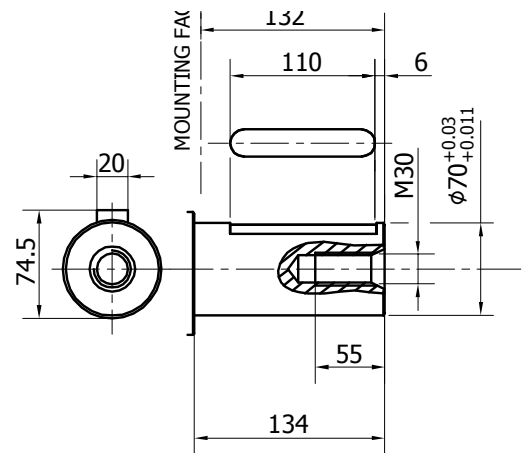

A3

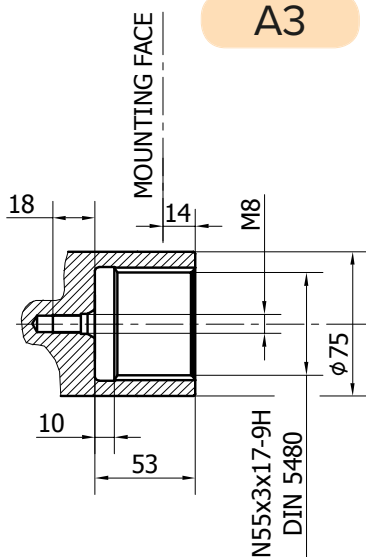

A31

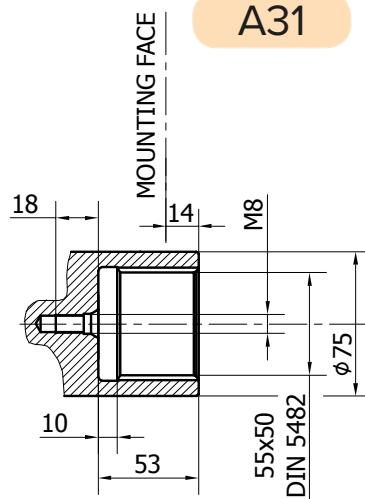

A4

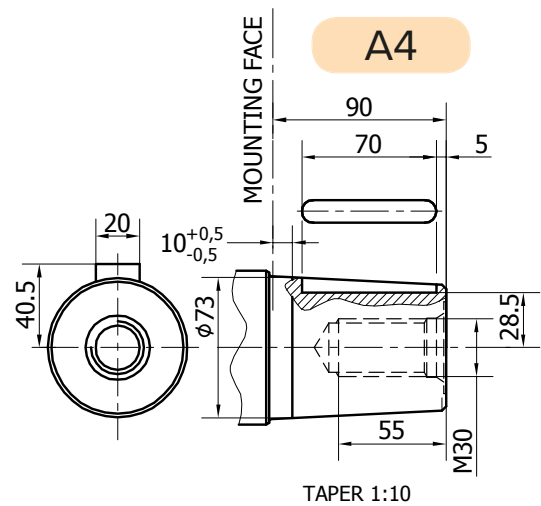

R8D H5/RM

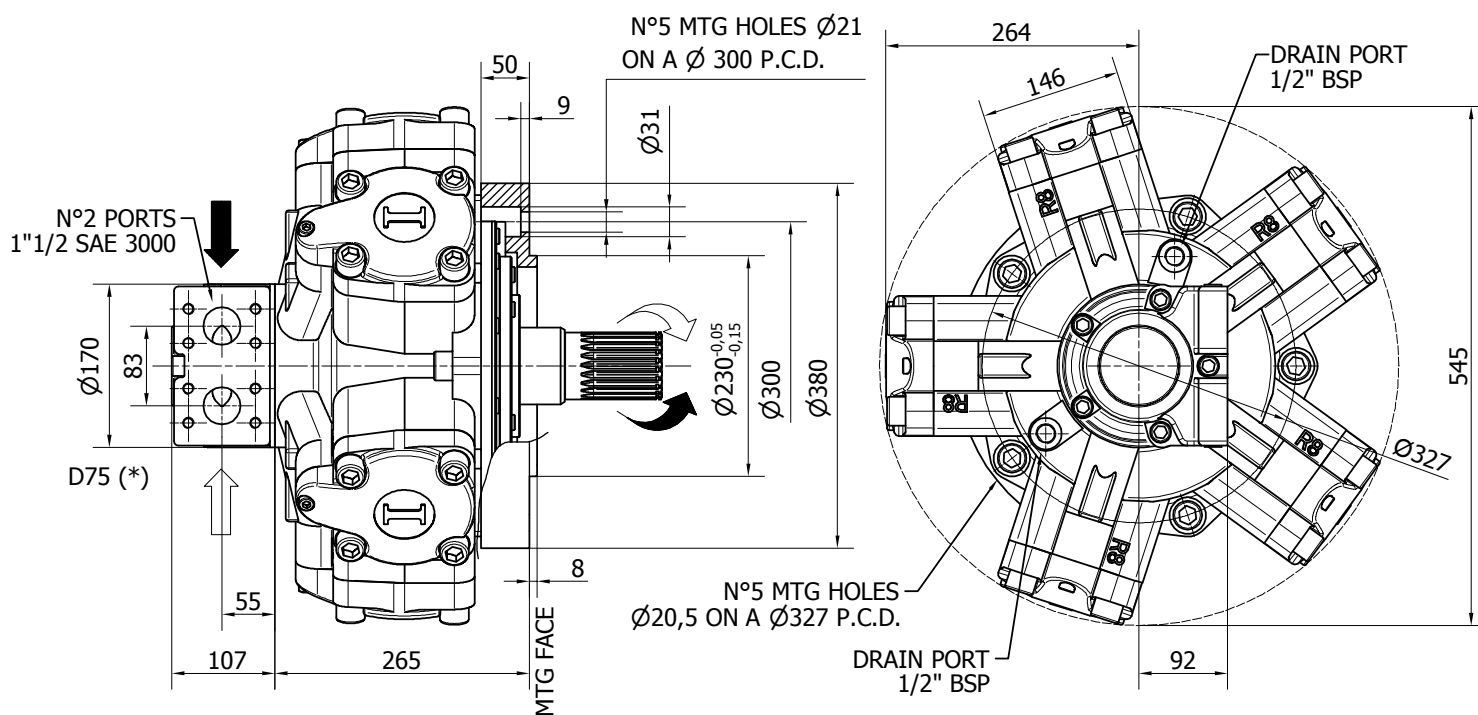

TECHNICAL DATA

		900	1000	1200	1400	1500	1600	1800	2000
DISPLACEMENT	[cc]	941	1094	1231	1376	1528	1648	1815	2034
SPECIFIC TORQUE	[Nm/bar]	15	17.4	19.6	21.9	24.3	26.2	28.9	32.4
MAX. CONT. PRESSURE	[bar]	270	270	270	270	270	270	250	190
HYDROSTATIC TEST PRESSURE	[bar]	420	420	420	420	420	420	420	420
MAX. CONT. SPEED	[rpm]	550	500	450	410	390	370	340	280
PEAK SPEED (***)	[rpm]	600	550	510	470	450	425	390	310
MAX. CONT. POWER (****)	[kW]	178	178	178	178	178	178	178	140
MAX. POWER	[kW]	210	210	210	210	210	210	210	160
MAX. CASE PRESSURE	[bar]	6	6	6	6	6	6	6	6
DRY WEIGHT	[kg]	173	173	173	173	173	173	173	173
TEMPERATURE RANGE (**)	[°C]	-30÷70	-30÷70	-30÷70	-30÷70	-30÷70	-30÷70	-30÷70	-30÷70

- (*) The standard distributor (D75) is shown. Please refer to distributors section (pag. 174-175) for different distributor interfaces.

- (**) Please refer to the hydraulic fluid recommendations (pag. 10-11).

- (***) Do not exceed maximum power (see pag. 13).

- (****) For motor operation with a continuous duty cycle at maximum continuous power the flushing is usually required. For more information please contact our technical department.

SHAFTS

A1

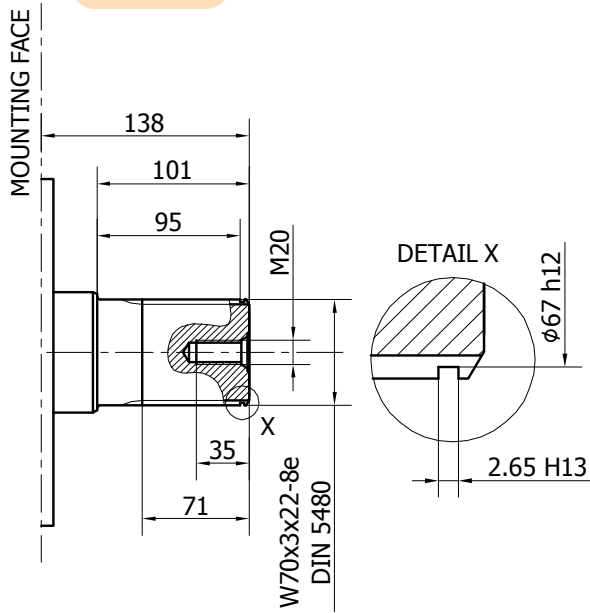

A23

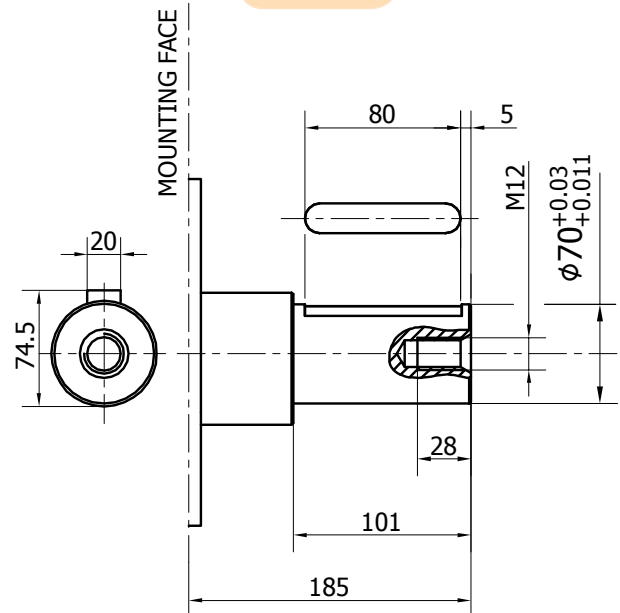

R8D H5 - PERFORMANCE CURVES

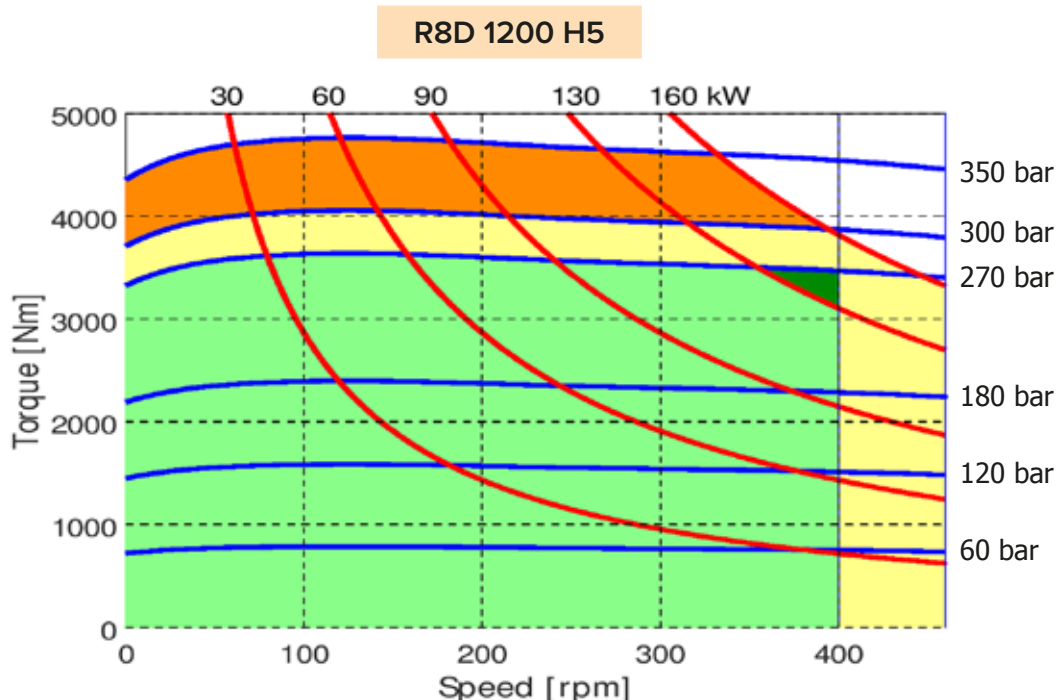
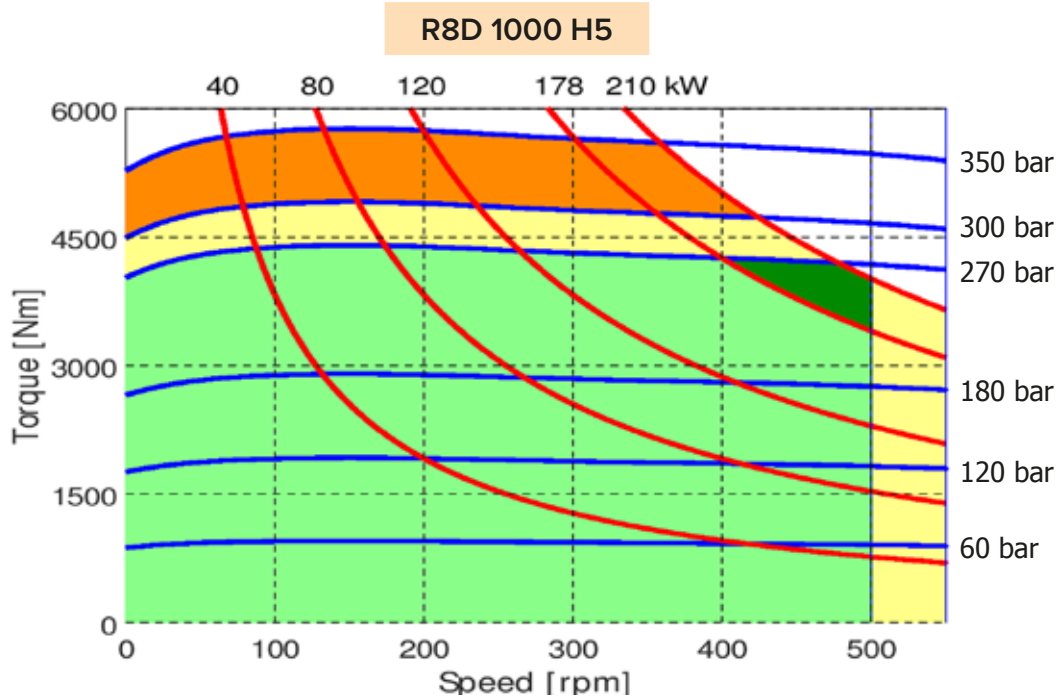

- Continuous operation
- Continuous operation with flushing or intermittent operation (see below for intermittent operation)
- Intermittent operation: permitted for a 15% of duty cycle, for 3 minutes maximum period
- Peak operation: permitted for very short periods (3-5 seconds every 10-15 minutes)

The above diagrams are referring to the hydraulic motor working with a fluid in ideal conditions (viscosity at 40 cSt). In case the working temperature increases and viscosity reach values under the recommended values (see hydraulic fluid recommendations) flushing must be performed or ISO oil grade must be changed. The working temperature must not overcome 70 °C.

R8D 1400 H5

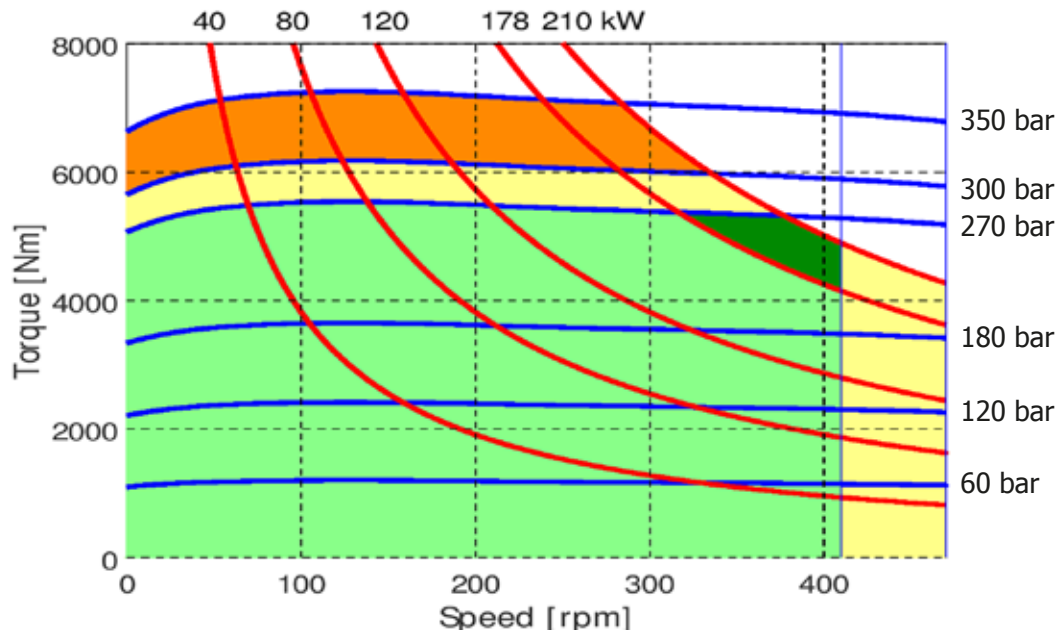

R8D 1500 H5

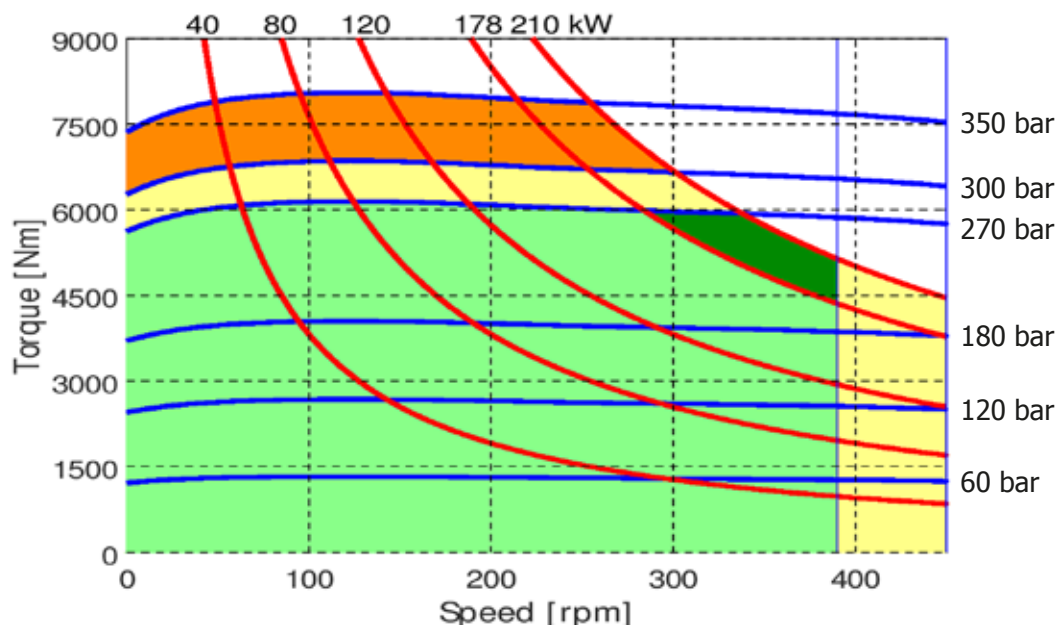

- Continuous operation
- Continuous operation with flushing or intermittent operation (see below for intermittent operation)
- Intermittent operation: permitted for a 15% of duty cycle, for 3 minutes maximum period
- Peak operation: permitted for very short periods (3-5 seconds every 10-15 minutes)

The above diagrams are referring to the hydraulic motor working with a fluid in ideal conditions (viscosity at 40 cSt). In case the working temperature increases and viscosity reach values under the recommended values (see hydraulic fluid recommendations) flushing must be performed or ISO oil grade must be changed. The working temperature must not overcome 70 °C.

R8D H5 - PERFORMANCE CURVES

R8D 1600 H5

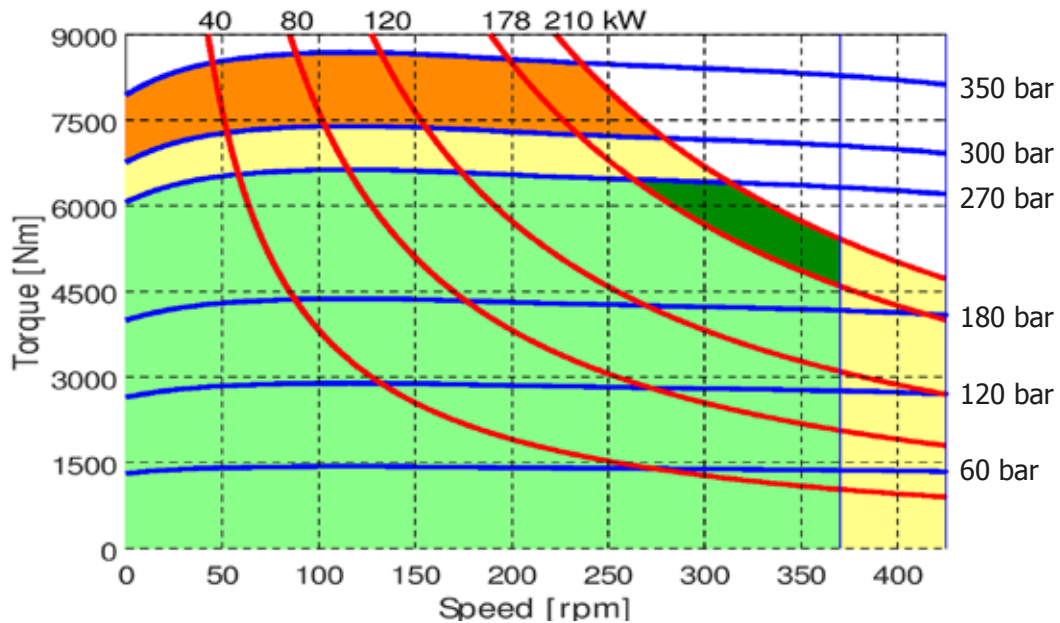

R8D 1800 H5

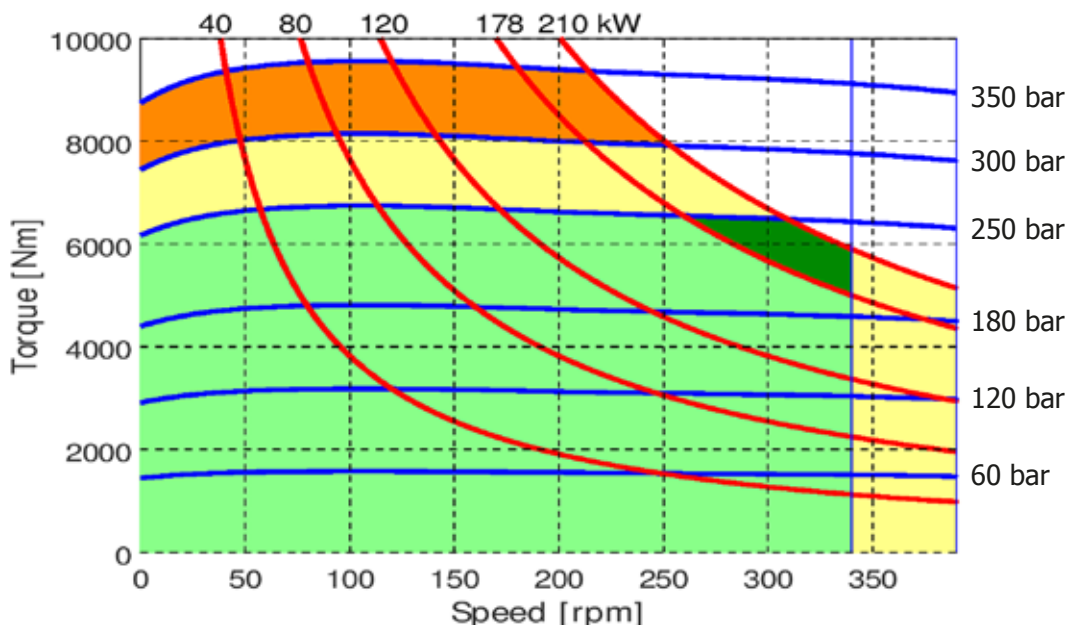

- Continuous operation
- Continuous operation with flushing or intermittent operation (see below for intermittent operation)
- Intermittent operation: permitted for a 15% of duty cycle, for 3 minutes maximum period
- Peak operation: permitted for very short periods (3-5 seconds every 10-15 minutes)

The above diagrams are referring to the hydraulic motor working with a fluid in ideal conditions (viscosity at 40 cSt). In case the working temperature increases and viscosity reach values under the recommended values (see hydraulic fluid recommendations) flushing must be performed or ISO oil grade must be changed. The working temperature must not overcome 70 °C.

R8D 2000 H5

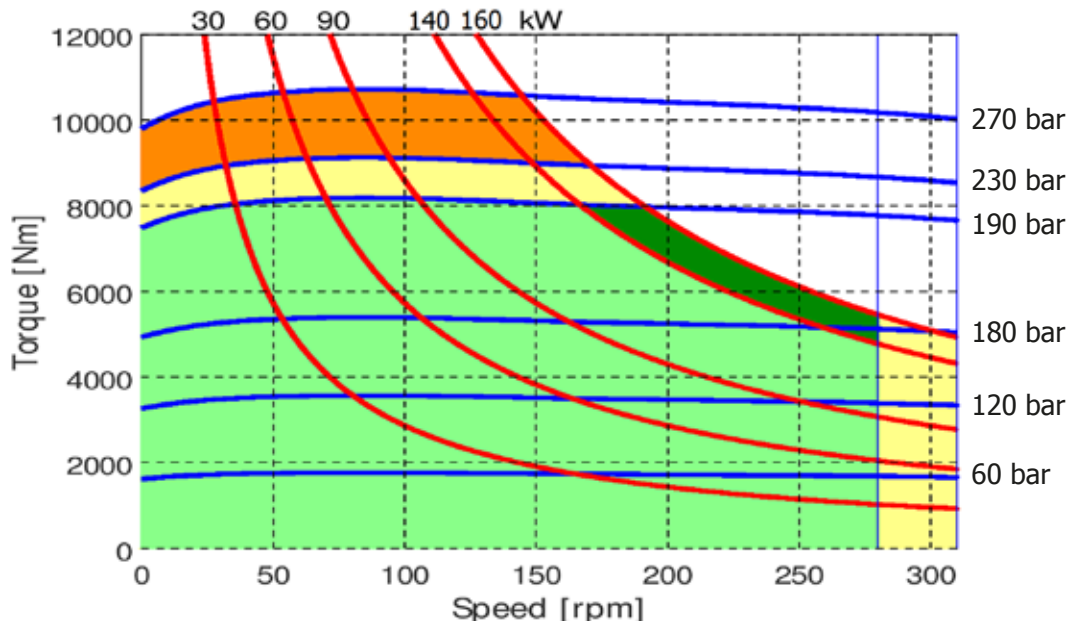

- Continuous operation
- Continuous operation with flushing or intermittent operation (see below for intermittent operation)
- Intermittent operation: permitted for a 15% of duty cycle, for 3 minutes maximum period
- Peak operation: permitted for very short periods (3-5 seconds every 10-15 minutes)

The above diagrams are referring to the hydraulic motor working with a fluid in ideal conditions (viscosity at 40 cSt). In case the working temperature increases and viscosity reach values under the recommended values (see hydraulic fluid recommendations) flushing must be performed or ISO oil grade must be changed. The working temperature must not overcome 70 °C.

R8D H5 - PERFORMANCE CURVES

CREEP SPEED - VOLUMETRIC EFFICIENCY

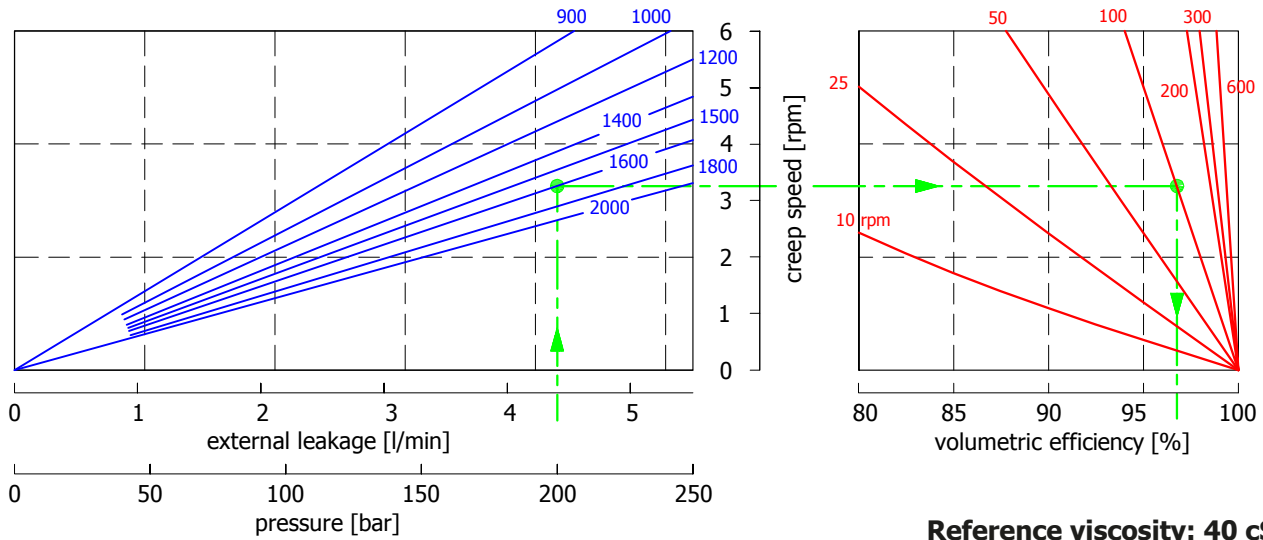

Reference viscosity: 40 cSt

Example:

We suppose (1600 cc): $p=200$ [bar], we obtain: external leakage 4,3 [l/min], shaft creep speed 3,2 [rpm].
 If we suppose (1600 cc): $p=200$ [bar] and $n=100$ [rpm] we obtain a volumetric efficiency of 97%;

BEARING LIFE

Reference displacement 1600 cc

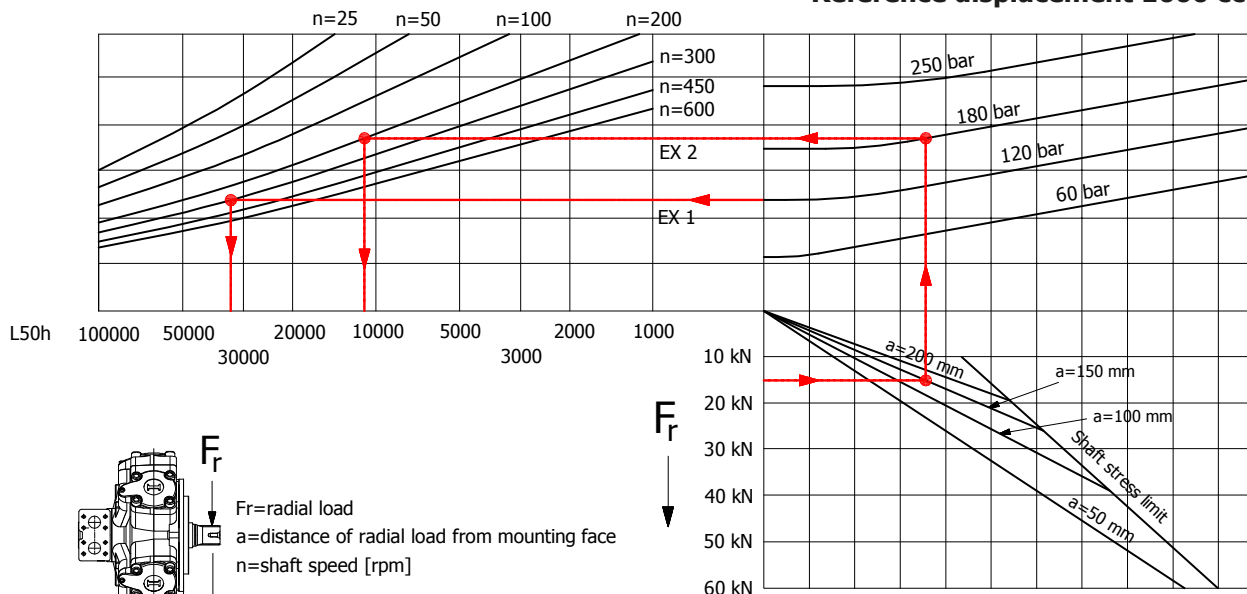

Reference viscosity: 40 cSt

Example:

We suppose (EX1): $p=120$ [bar], $n=300$ [rpm]; we obtain an average lifetime of 33000 [h].
 If we suppose (EX2): $F_r=15$ [kN], $a=150$ [mm], $n=200$ [rpm] and $p=180$ [bar] we obtain an average lifetime of 11000 [h].

R8D H5 - ORDERING CODE

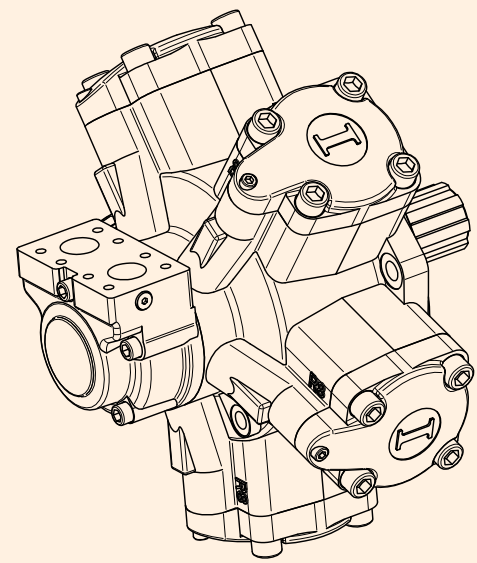
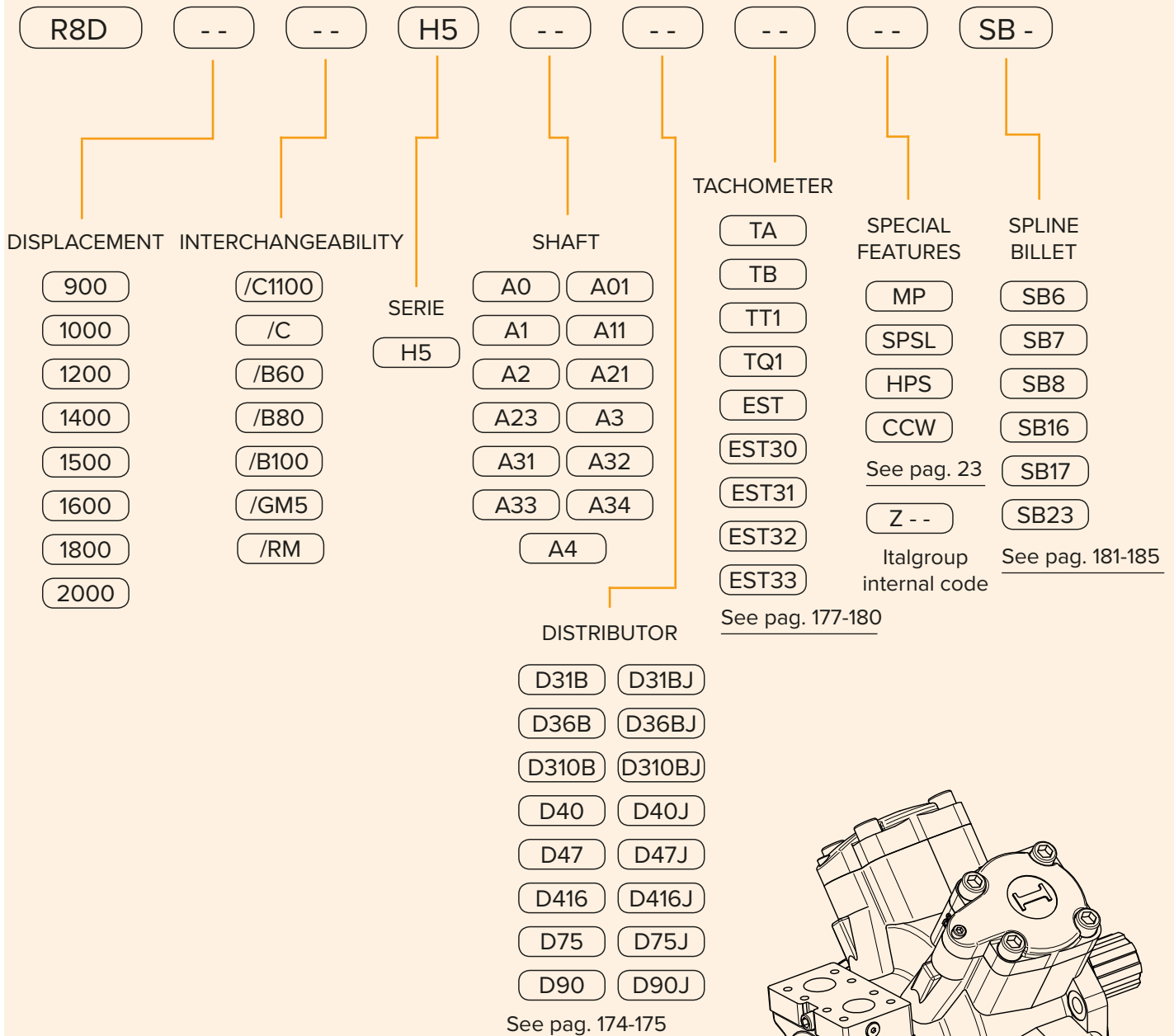

EXAMPLES:

- R8D 1000 H5 A1 D75 SB7
- R8D 1400/C1100 H5 A0 D75
- R8D 2000 H5 A0 D90 CCW SB6

R8D H55

R8D H55	Pag. 102 - 103
R8D H55/MR1800 D75	Pag. 104 - 105
R8D H55/MR1800 D90	Pag. 106 - 107
R8D H55 - PERFORMANCE CURVES	Pag. 108 - 112
R8D H55 - ORDERING CODE	Pag. 113

R8D H55

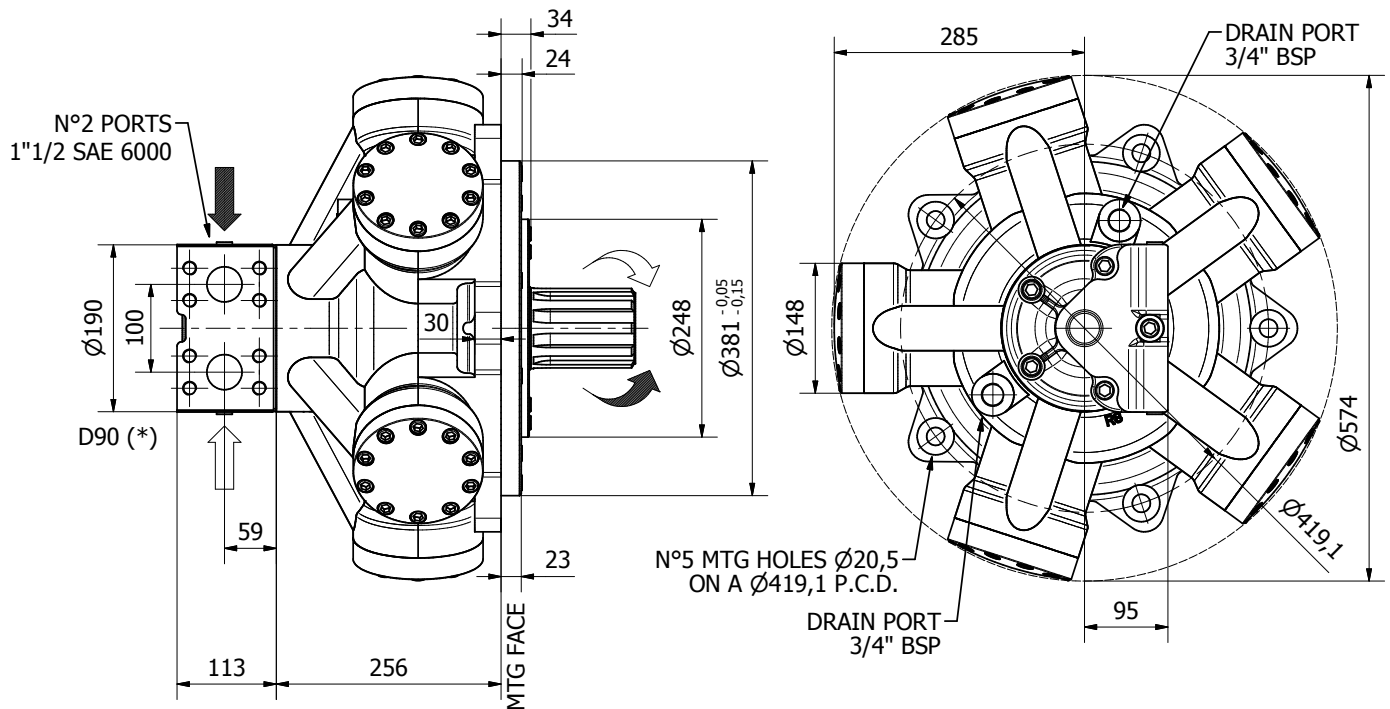

Available distributor flange: **FL7**

Refer to page 186-187
(distributor fitting D75)

TECHNICAL DATA

		1800	2150	2300	2400
DISPLACEMENT	[cc]	1800	2126	2293	2393
SPECIFIC TORQUE	[Nm/bar]	28.7	33.8	36.5	38.1
MAX. CONT. PRESSURE	[bar]	270	270	250	250
HYDROSTATIC TEST PRES-SURE	[bar]	420	420	420	420
MAX. CONT. SPEED	[rpm]	265	235	210	190
PEAK SPEED (***)	[rpm]	290	260	235	220
MAX. CONT. POWER (****)	[kW]	190	190	180	170
MAX. POWER	[kW]	220	220	210	210
MAX. CASE PRESSURE	[bar]	6	6	6	6
DRY WEIGHT	[kg]	203	203	203	203
TEMPERATURE RANGE (**)	[°C]	-30÷70	-30÷70	-30÷70	-30÷70

- (*) The standard distributor (D90) is shown. Please refer to distributors section (pag. 174-175) for different distributor interfaces.

- (**) Please refer to the hydraulic fluid recommendations (pag. 10-11).

- (***) Do not exceed maximum power (see pag. 13).

- (****) For motor operation with a continuous duty cycle at maximum continuous power the flushing is usually required. For more information please contact our technical department.

SHAFTS

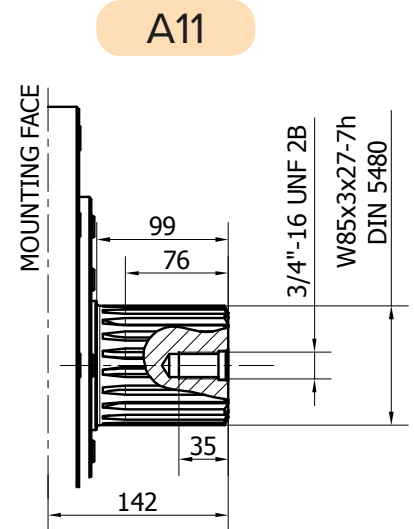
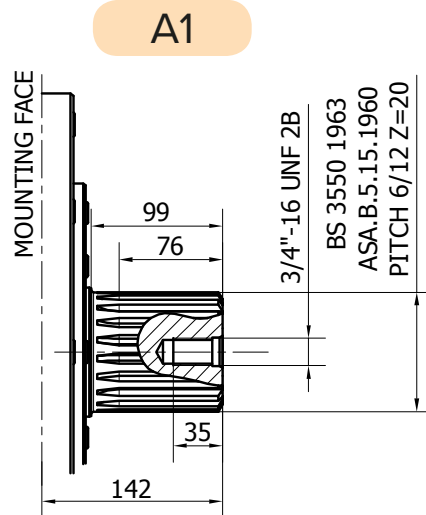
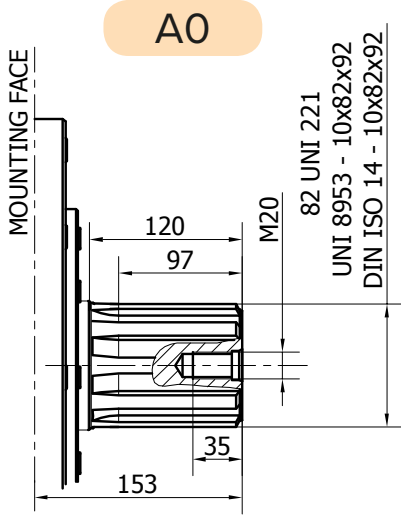

Available spline billet: SB9

Available spline billet: SB10

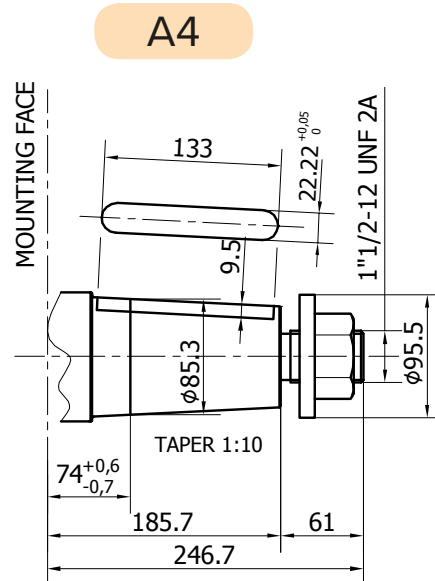
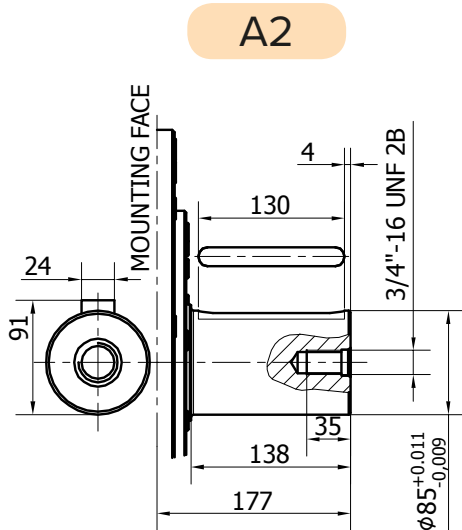

R8D H55/MR1800 D75

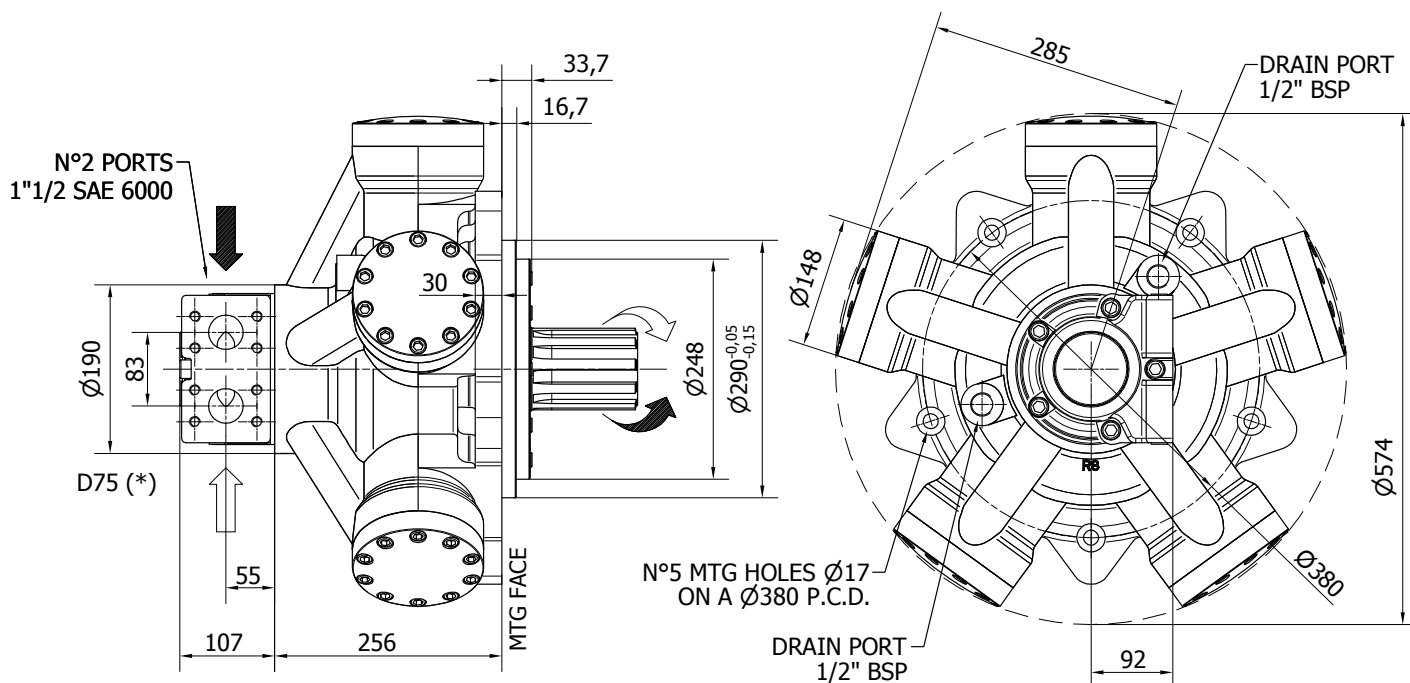

Available distributor flange: **FL4**

For S04, refer to page 186-187
(distributor fitting D75)

TECHNICAL DATA

		1800	2100	2200
DISPLACEMENT	[cc]	1800	2035	2193
SPECIFIC TORQUE	[Nm/bar]	28.7	32.4	34.9
MAX. CONT. PRESSURE	[bar]	270	270	270
HYDROSTATIC TEST PRES-SURE	[bar]	420	420	420
MAX. CONT. SPEED	[rpm]	265	235	220
PEAK SPEED (**)	[rpm]	290	260	240
MAX. CONT. POWER (***)	[kW]	190	190	190
MAX. POWER	[kW]	220	220	220
MAX. CASE PRESSURE	[bar]	6	6	6
DRY WEIGHT	[kg]	203	203	203
TEMPERATURE RANGE (**)	[°C]	-30÷70	-30÷70	-30÷70

- (*) The standard distributor (D75) is shown. Please refer to distributors section (pag. 174-175) for different distributor interfaces.

- (**) Please refer to the hydraulic fluid recommendations (pag. 10-11).

- (***) Do not exceed maximum power (see pag. 13).

- (****) For motor operation with a continuous duty cycle at maximum continuous power the flushing is usually required. For more information please contact our technical department.

SHAFTS

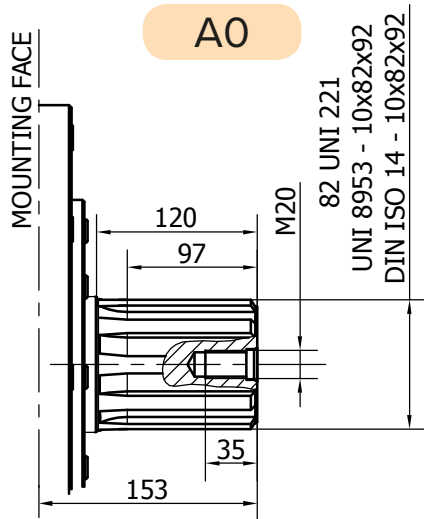

Available spline billet: SB9

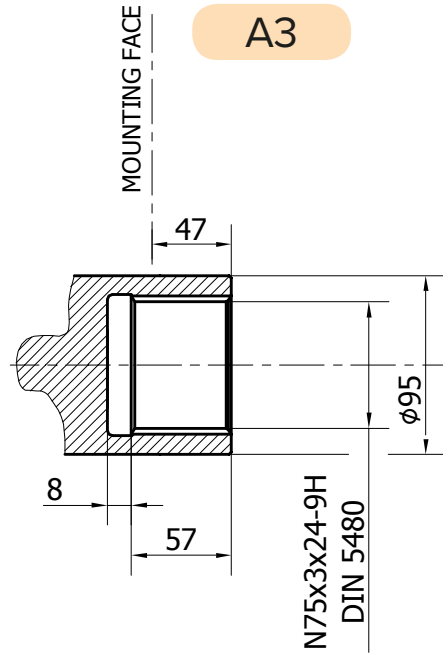

R8D H55/MR1800 D90

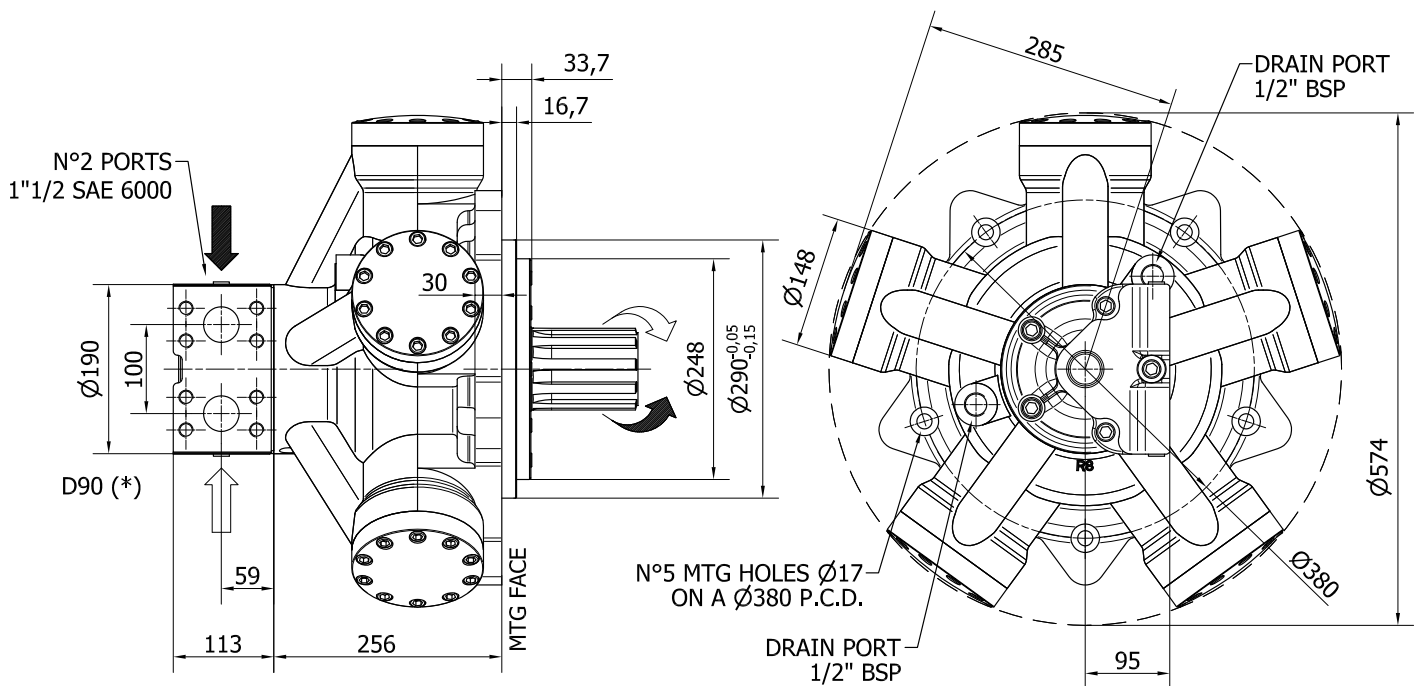

TECHNICAL DATA

		2000	2200	2400
DISPLACEMENT	[cc]	1962	2193	2393
SPECIFIC TORQUE	[Nm/bar]	31.2	34.9	38.1
MAX. CONT. PRESSURE	[bar]	270	270	250
HYDROSTATIC TEST PRESSURE	[bar]	420	420	420
MAX. CONT. SPEED	[rpm]	245	220	190
PEAK SPEED (***)	[rpm]	270	240	220
MAX. CONT. POWER (****)	[kW]	190	190	170
MAX. POWER	[kW]	220	220	210
MAX. CASE PRESSURE	[bar]	6	6	6
DRY WEIGHT	[kg]	203	203	203
TEMPERATURE RANGE (**)	[°C]	-30÷70	-30÷70	-30÷70

- (*) The standard distributor (D90) is shown. Please refer to distributors section (pag. 174-175) for different distributor interfaces.

- (**) Please refer to the hydraulic fluid recommendations (pag. 10-11).

- (***) Do not exceed maximum power (see pag. 13).

- (****) For motor operation with a continuous duty cycle at maximum continuous power the flushing is usually required. For more information please contact our technical department.

SHAFTS

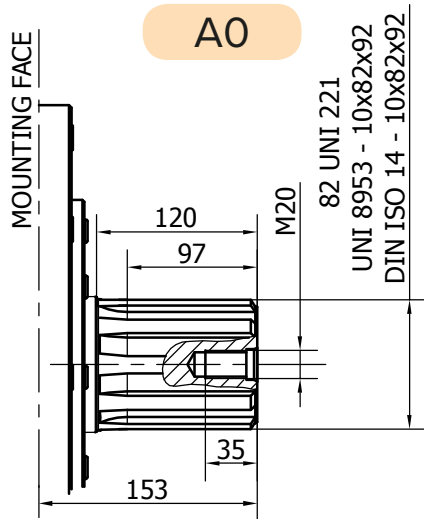

Available spline billet: SB9

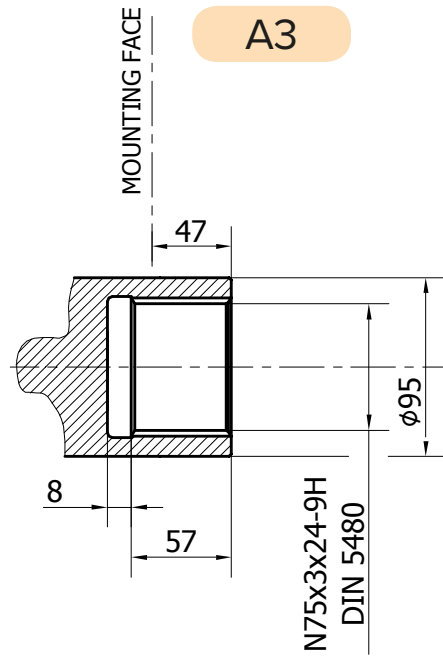

R8D H55 - PERFORMANCE CURVES

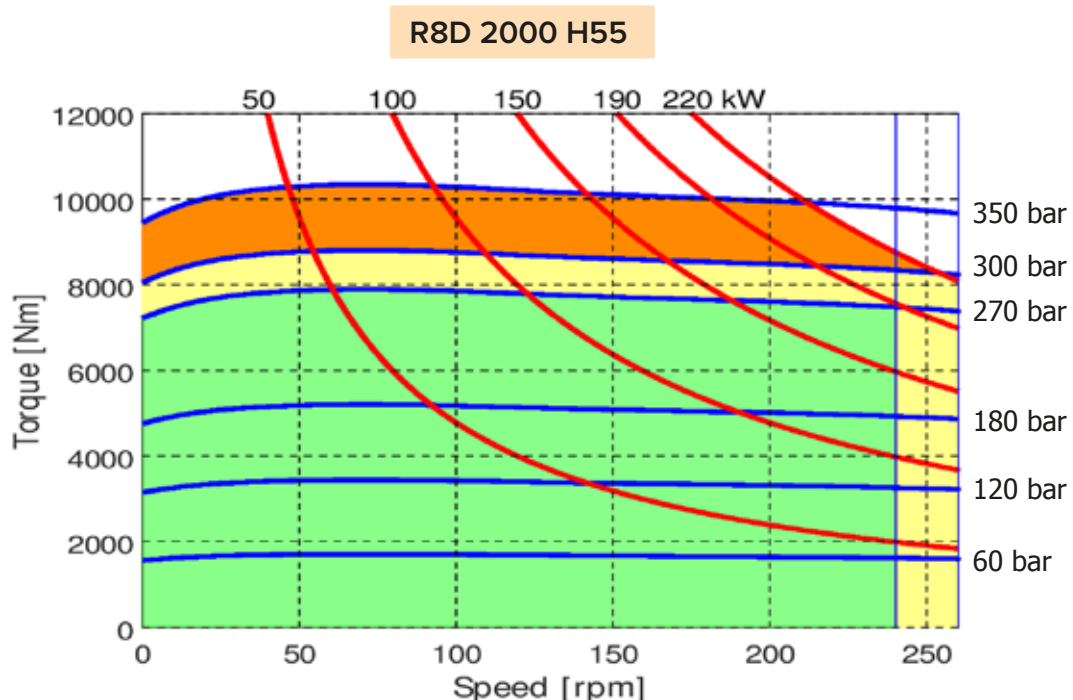
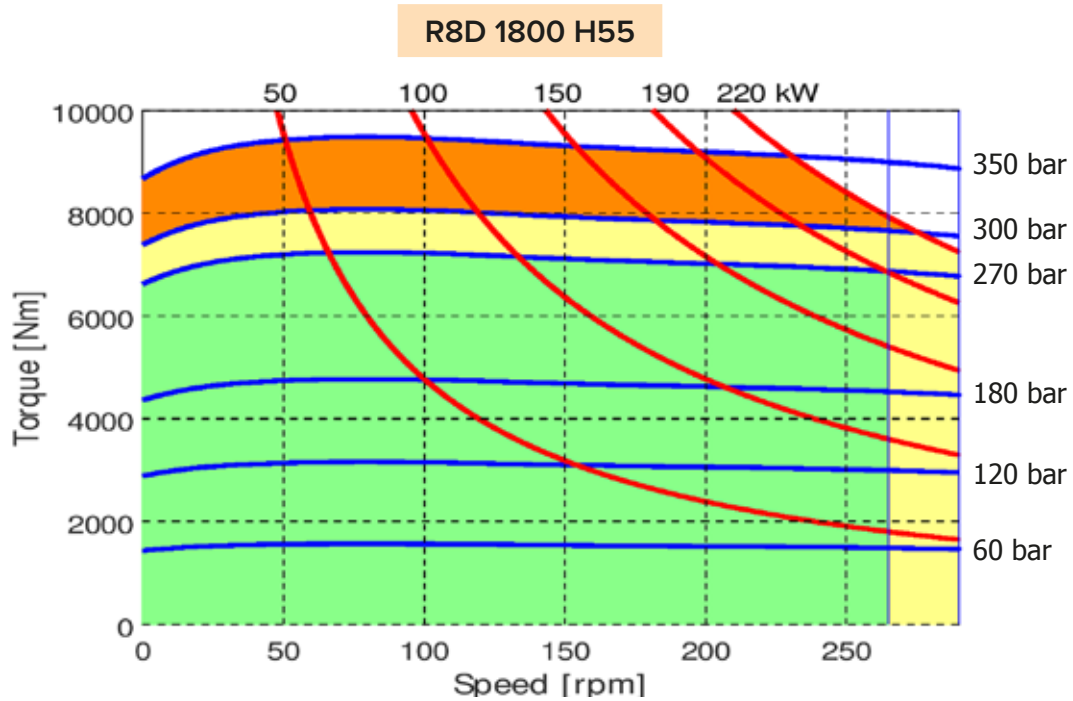

- Continuous operation
- Continuous operation with flushing or intermittent operation (see below for intermittent operation)
- Intermittent operation: permitted for a 15% of duty cycle, for 3 minutes maximum period
- Peak operation: permitted for very short periods (3-5 seconds every 10-15 minutes)

The above diagrams are referring to the hydraulic motor working with a fluid in ideal conditions (viscosity at 40 cSt). In case the working temperature increases and viscosity reach values under the recommended values (see hydraulic fluid recommendations) flushing must be performed or ISO oil grade must be changed. The working temperature must not overcome 70 °C.

R8D 2100 H55

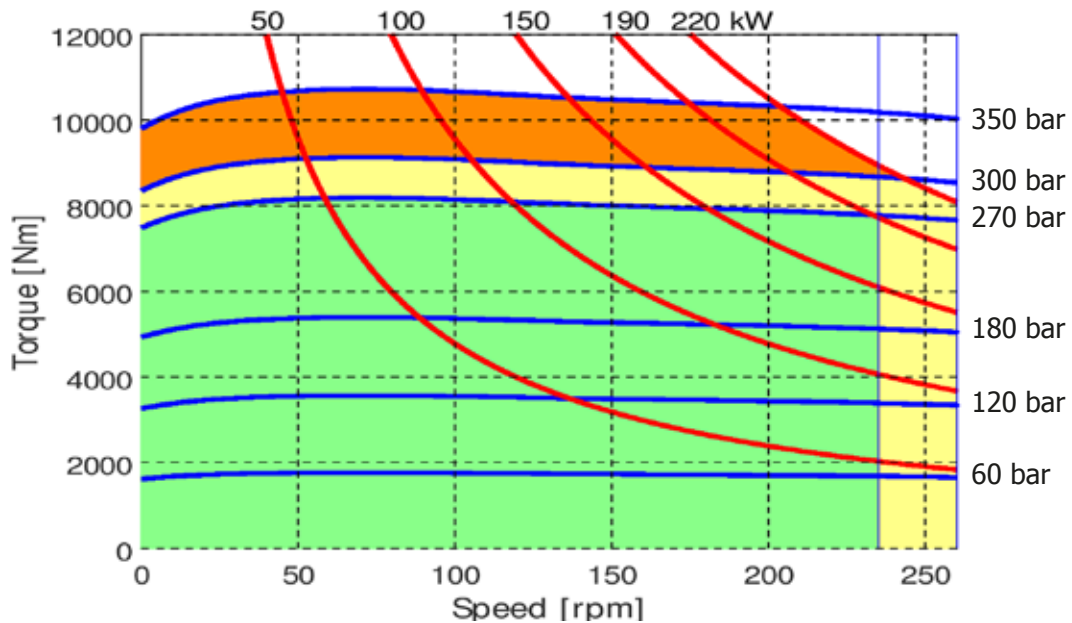

R8D 2150 H55

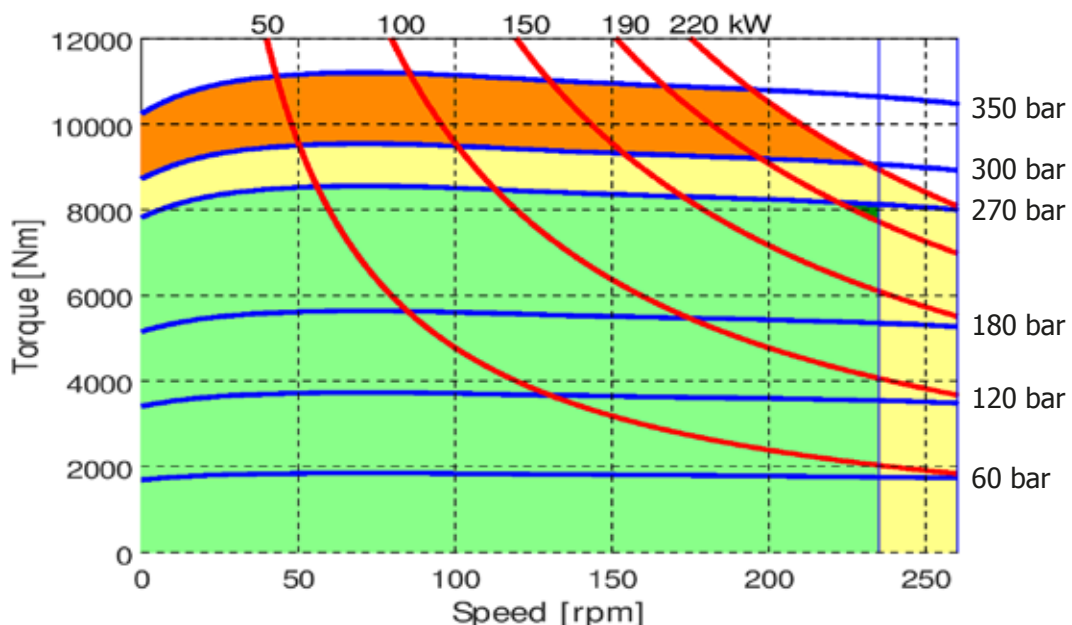

- Continuous operation
- Continuous operation with flushing or intermittent operation (see below for intermittent operation)
- Intermittent operation: permitted for a 15% of duty cycle, for 3 minutes maximum period
- Peak operation: permitted for very short periods (3-5 seconds every 10-15 minutes)

The above diagrams are referring to the hydraulic motor working with a fluid in ideal conditions (viscosity at 40 cSt). In case the working temperature increases and viscosity reach values under the recommended values (see hydraulic fluid recommendations) flushing must be performed or ISO oil grade must be changed. The working temperature must not overcome 70 °C.

R8D H55 - PERFORMANCE CURVES

R8D 2200 H55

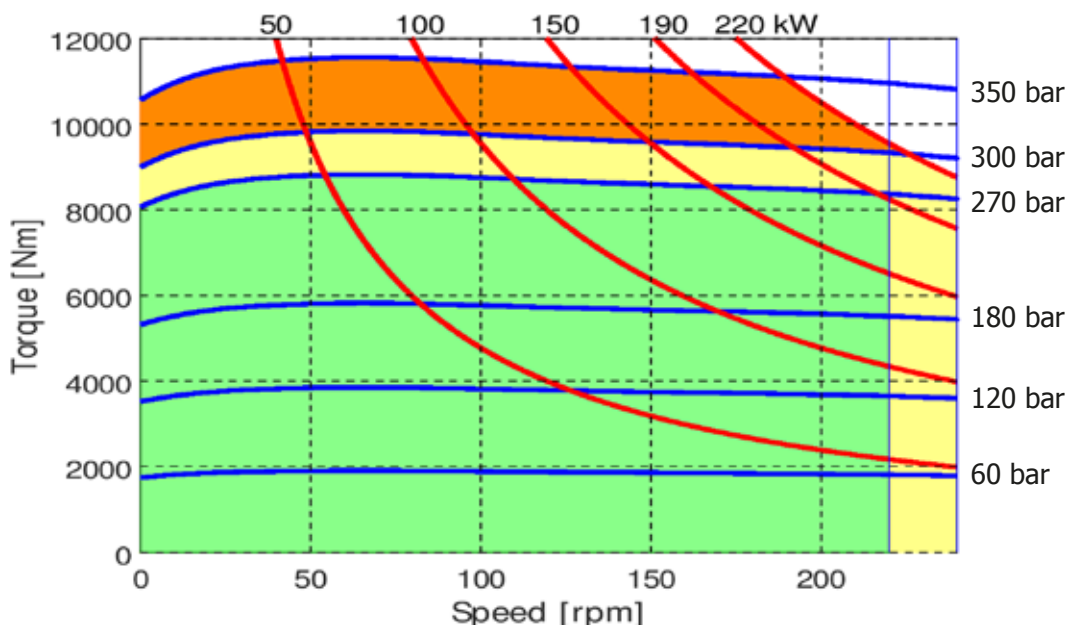

R8D 2300 H55

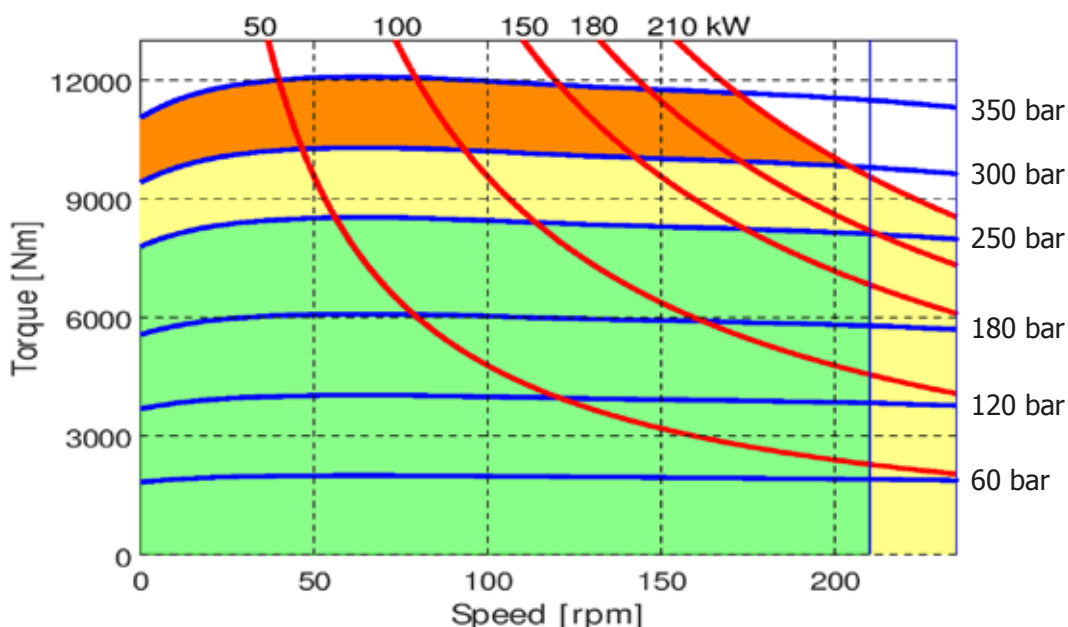



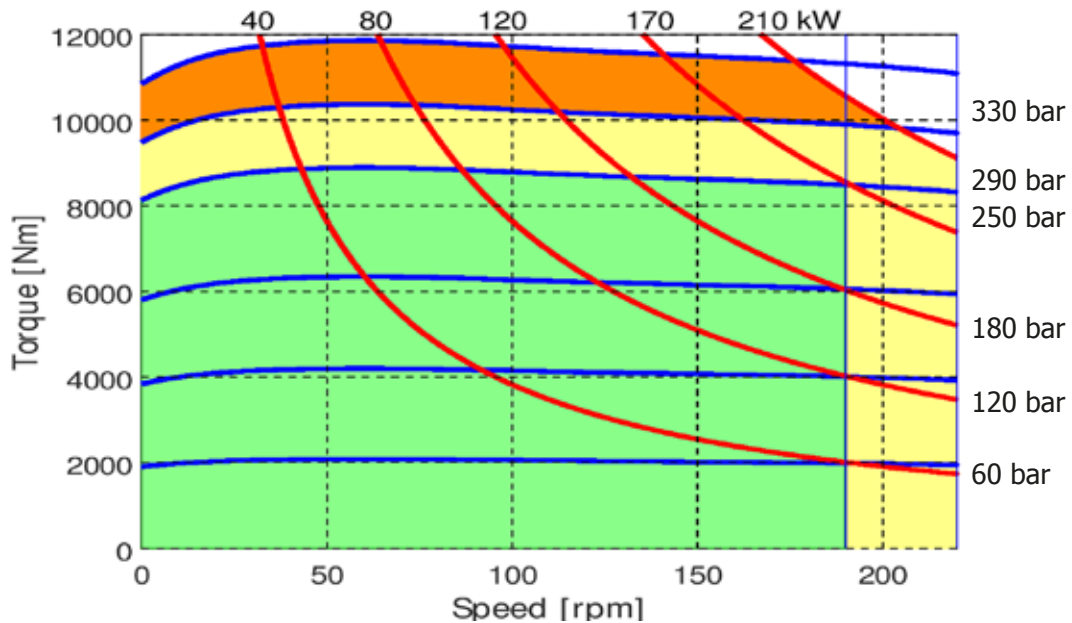

- Continuous operation
- Continuous operation with flushing or intermittent operation (see below for intermittent operation)
- Intermittent operation: permitted for a 15% of duty cycle, for 3 minutes maximum period
- Peak operation: permitted for very short periods (3-5 seconds every 10-15 minutes)

The above diagrams are referring to the hydraulic motor working with a fluid in ideal conditions (viscosity at 40 cSt). In case the working temperature increases and viscosity reach values under the recommended values (see hydraulic fluid recommendations) flushing must be performed or ISO oil grade must be changed. The working temperature must not overcome 70 °C.

R8D 2400 H55

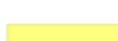

-  Continuous operation
-  Continuous operation with flushing or intermittent operation (see below for intermittent operation)
-  Intermittent operation: permitted for a 15% of duty cycle, for 3 minutes maximum period
-  Peak operation: permitted for very short periods (3-5 seconds every 10-15 minutes)

The above diagrams are referring to the hydraulic motor working with a fluid in ideal conditions (viscosity at 40 cSt). In case the working temperature increases and viscosity reach values under the recommended values (see hydraulic fluid recommendations) flushing must be performed or ISO oil grade must be changed. The working temperature must not overcome 70 °C.

R8D H55 - PERFORMANCE CURVES

CREEP SPEED - VOLUMETRIC EFFICIENCY

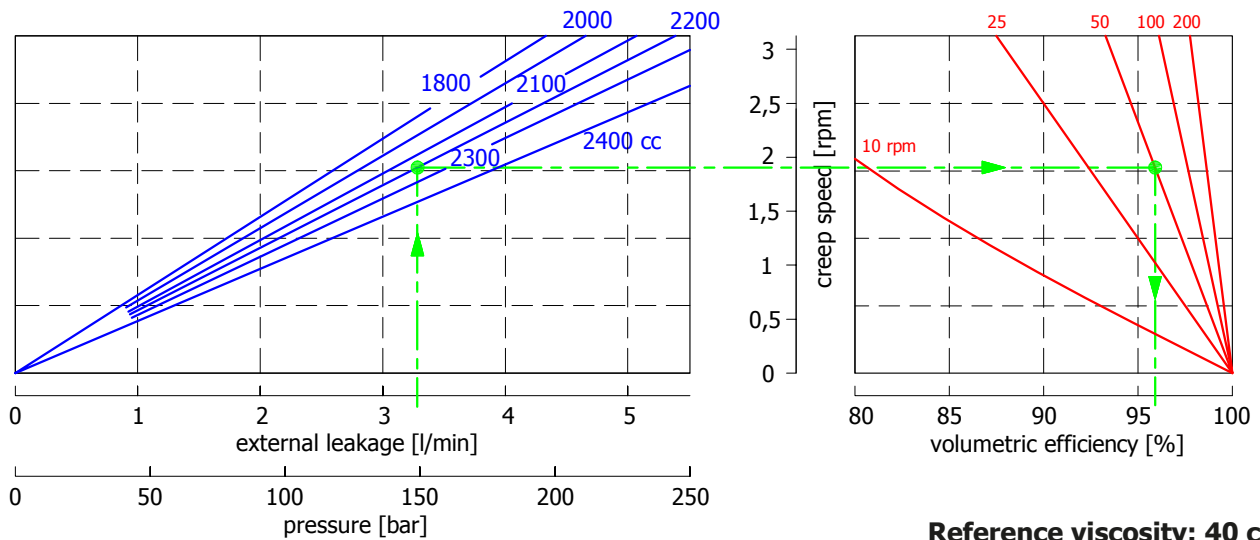

Reference viscosity: 40 cSt

Example:

We suppose (2200 cc): $p=150$ [bar], we obtain: external leakage 3,2 [l/min], shaft creep speed 1,9 [rpm].
 If we suppose (2200 cc): $p=150$ [bar] and $n=50$ [rpm] we obtain a volumetric efficiency of 96%;

BEARING LIFE

Reference displacement 2300 cc

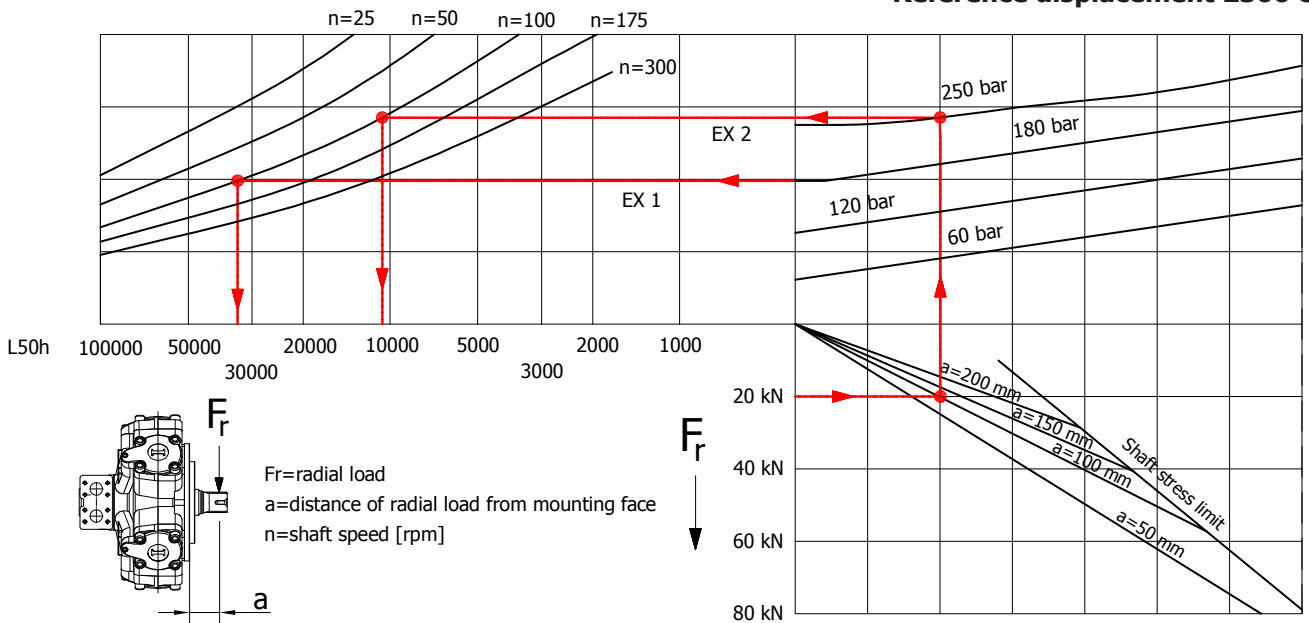

Reference viscosity: 40 cSt

Example:

We suppose (EX1): $p=180$ [bar], $n=100$ [rpm]; we obtain an average lifetime of 33000 [h].
 If we suppose (EX2): $F_r=20$ [kN], $a=100$ [mm], $n=100$ [rpm] and $p=250$ [bar] we obtain an average lifetime of 11000 [h].

R8D H55 - ORDERING CODE

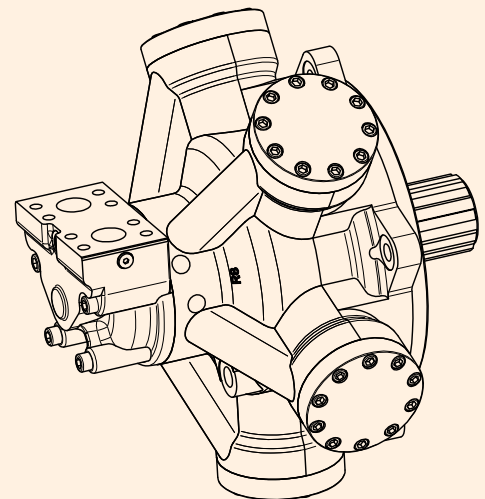
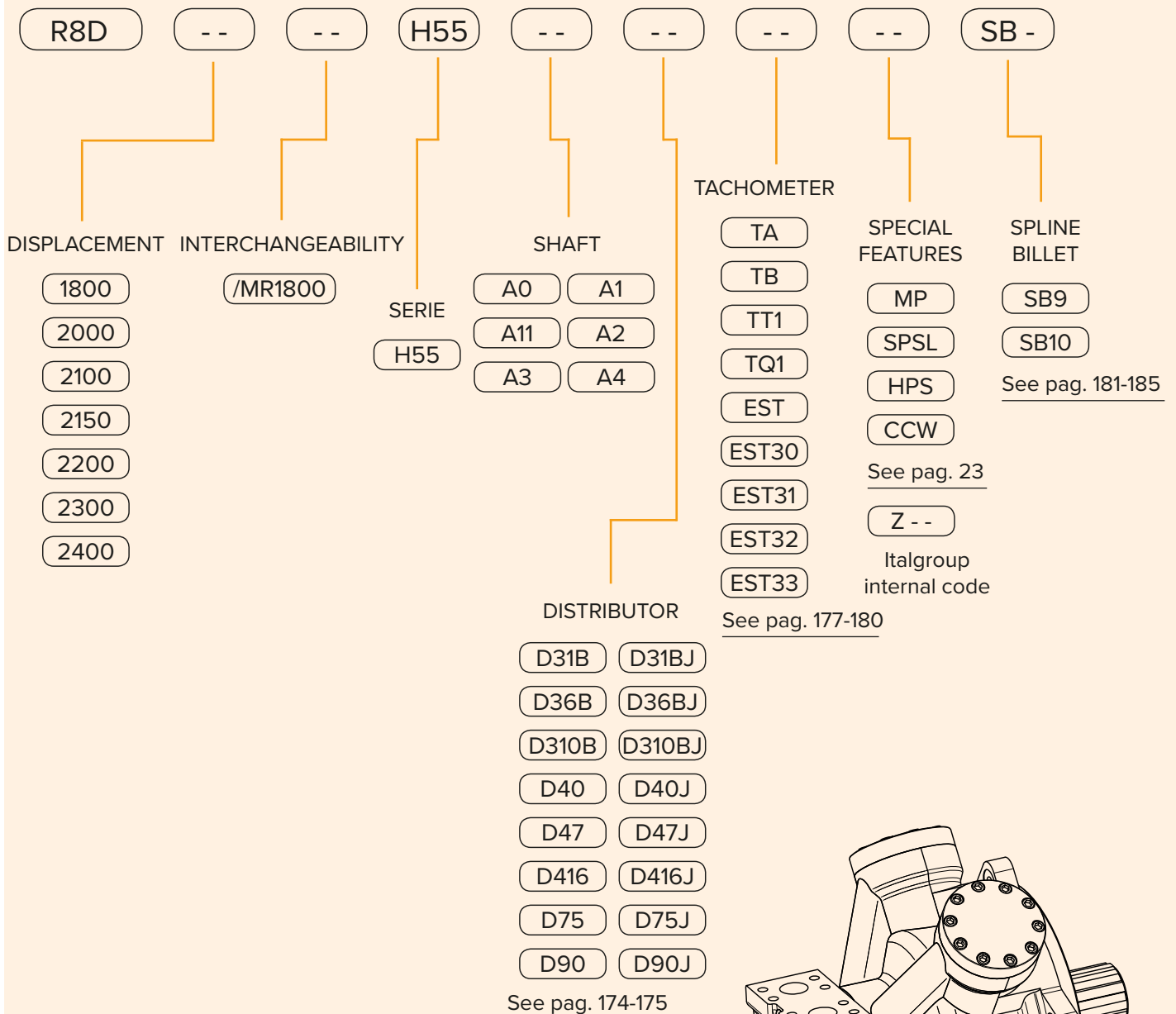

EXAMPLES:

R8D 2150 H55 A1 D90 SB10
R8D 2400/MR1800 H55 A0 D90
R8D 2100/MR1800 H55 A3 D75

R8D H6

R8D H6	Pag. 116 - 119
R8D H6/C	Pag. 120 - 121
R8D 2200/B125-2500/B150-3000/B200 H6	Pag. 122 - 123
R8D/GM6 H6	Pag. 124 - 125
R8D/PL H6	Pag. 126 - 127
R8D H6 - PERFORMANCE CURVES	Pag. 128 - 132
R8D H6 - ORDERING CODE	Pag. 133

R8D H6

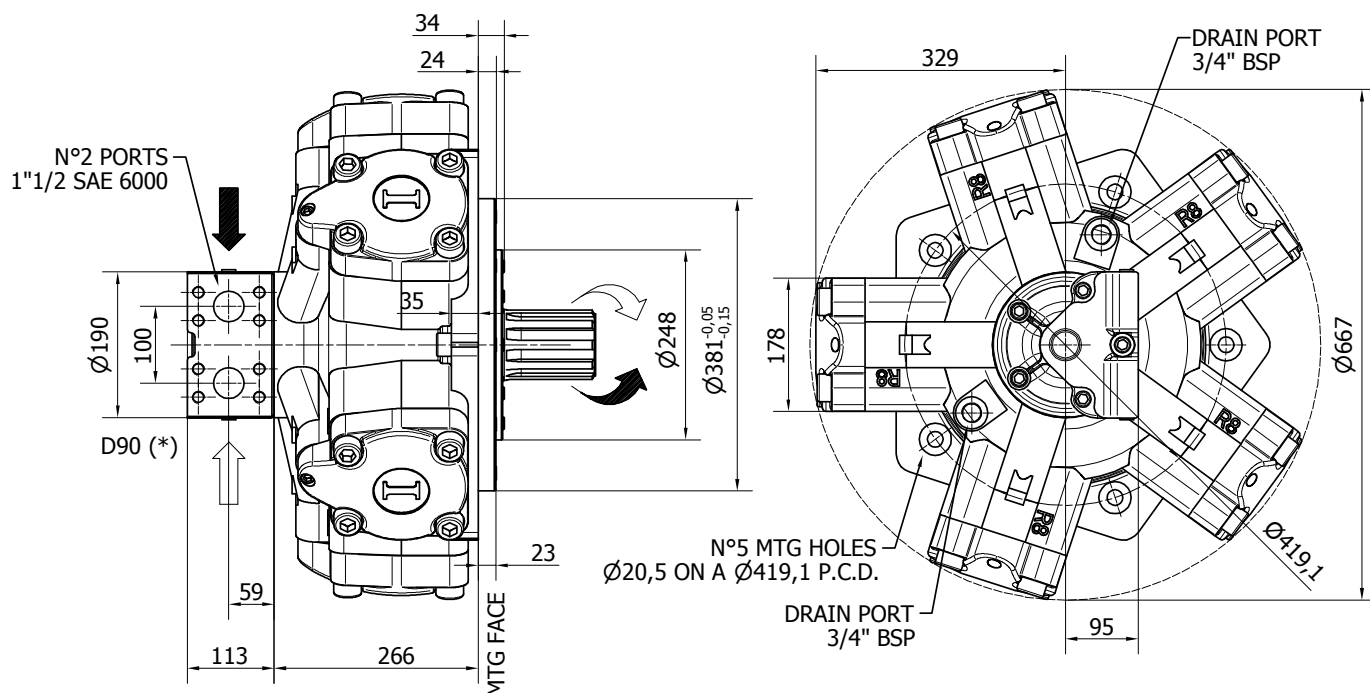

Available distributor flange: **FL7**

For S04, refer to page 186-187
(distributor fitting D90)

TECHNICAL DATA

		1800	2000	2200	2500	2800	3000	3200	3500
DISPLACEMENT	[cc]	1866	1993	2206	2525	2807	2983	3289	3479
SPECIFIC TORQUE	[Nm/bar]	29.7	31.7	35.1	40.2	44.7	47.5	52.4	55.4
MAX. CONT. PRESSURE	[bar]	270	270	270	270	270	270	270	270
HYDROSTATIC TEST PRESSURE	[bar]	420	420	420	420	420	420	420	420
MAX. CONT. SPEED	[rpm]	350	350	325	285	250	235	210	200
PEAK SPEED (**)	[rpm]	400	400	375	325	290	270	240	230
MAX. CONT. POWER (***)	[kW]	220	220	220	220	220	220	220	210
MAX. POWER	[kW]	245	245	245	245	245	245	245	235
MAX. CASE PRESSURE	[bar]	6	6	6	6	6	6	6	6
DRY WEIGHT	[kg]	308	308	308	308	308	308	308	308
TEMPERATURE RANGE (**)	[°C]	-30÷70	-30÷70	-30÷70	-30÷70	-30÷70	-30÷70	-30÷70	-30÷70

- (*) The standard distributor (D90) is shown. Please refer to distributors section (pag. 174-175) for different distributor interfaces.

- (***) Please refer to the hydraulic fluid recommendations (pag. 10-11).

- (****) Do not exceed maximum power (see pag. 13).

- (*****) For motor operation with a continuous duty cycle at maximum continuous power the flushing is usually required. For more information please contact our technical department.

SHAFTS

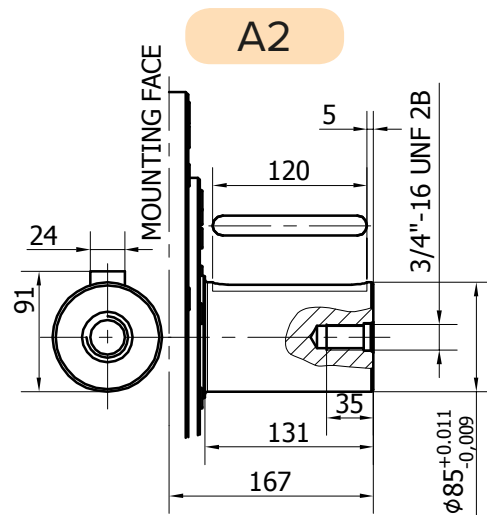
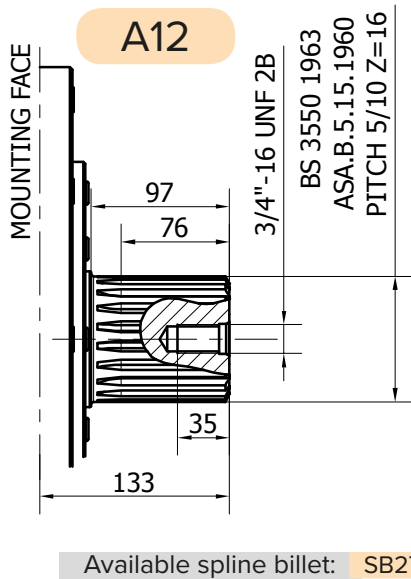
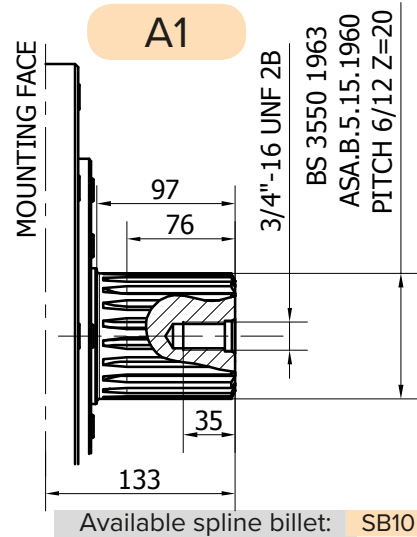
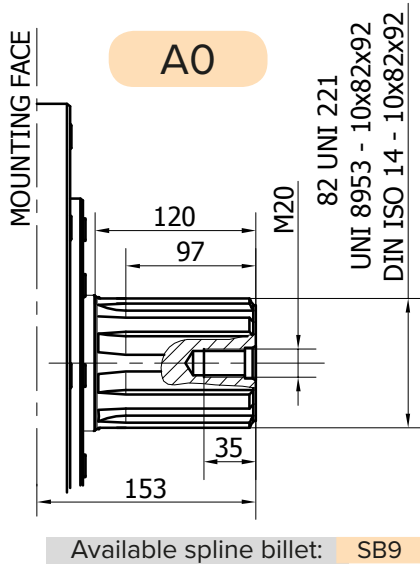

R8D H6

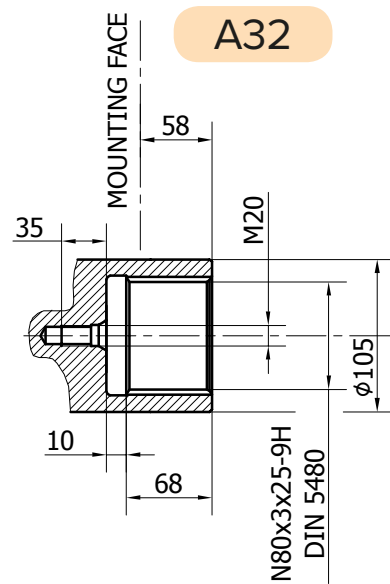
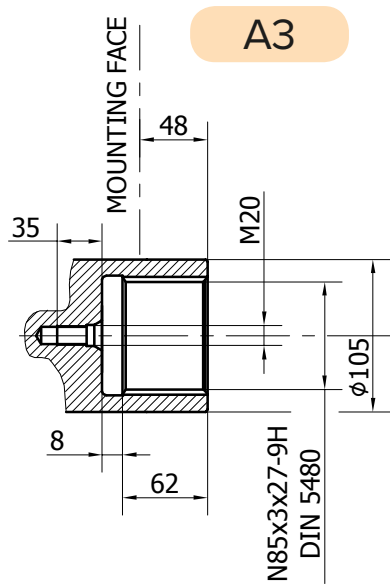
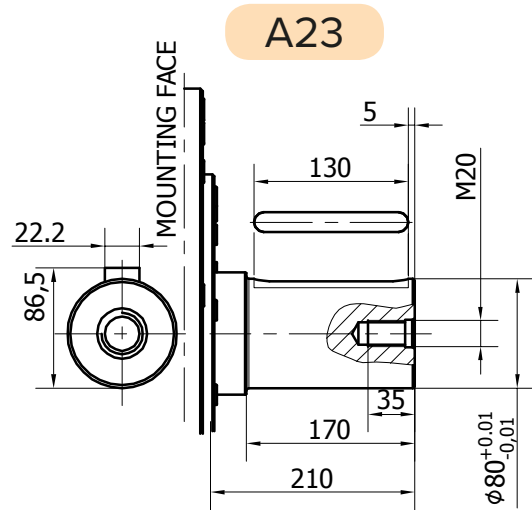
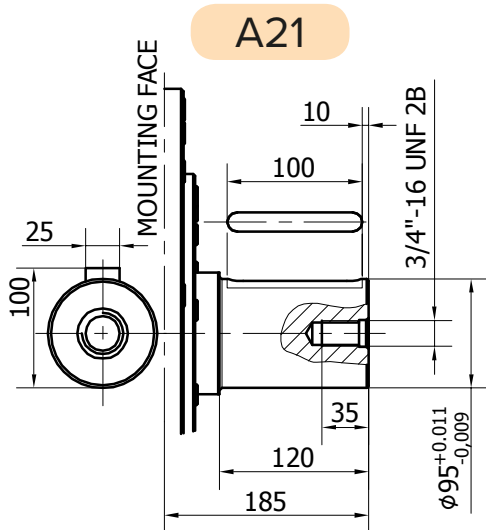

SHAFTS

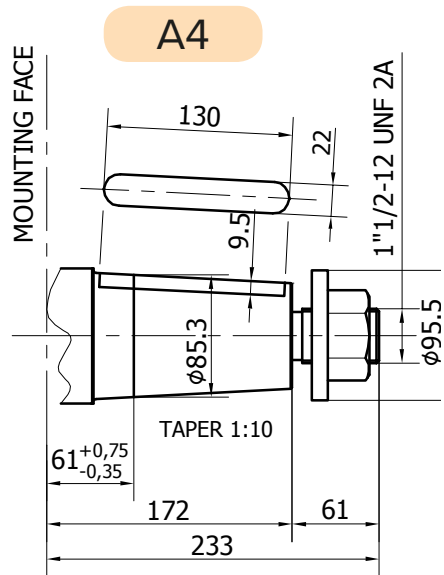

R8D H6/C

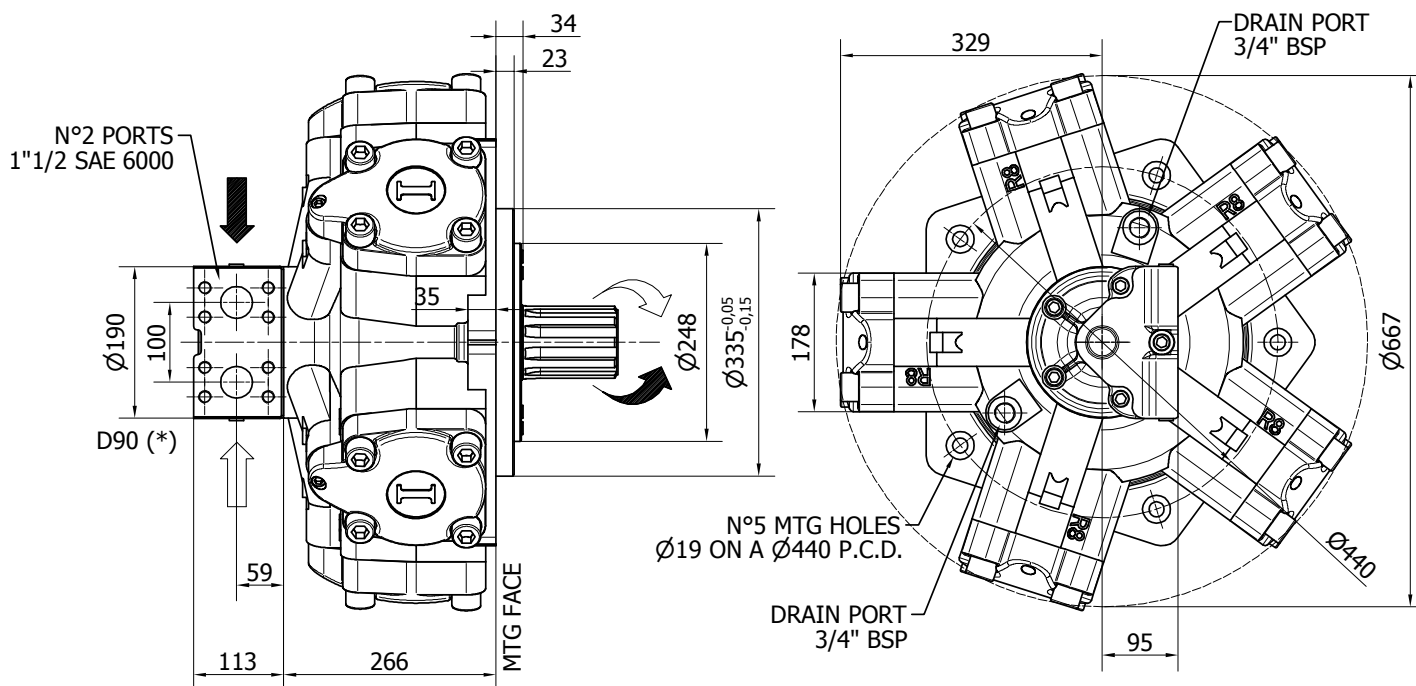

Available distributor flange: **FL10**

For S04, refer to page 186-187
(distributor fitting D75)

TECHNICAL DATA

		1800	2000	2200	2500	2800	3000	3200	3500
DISPLACEMENT	[cc]	1866	1993	2206	2525	2807	2983	3289	3479
SPECIFIC TORQUE	[Nm/bar]	29.7	31.7	35.1	40.2	44.7	47.5	52.4	55.4
MAX. CONT. PRESSURE	[bar]	270	270	270	270	270	270	270	270
HYDROSTATIC TEST PRESSURE	[bar]	420	420	420	420	420	420	420	420
MAX. CONT. SPEED	[rpm]	350	350	325	285	250	235	210	200
PEAK SPEED (**)	[rpm]	400	400	375	325	290	270	240	230
MAX. CONT. POWER (***)	[kW]	220	220	220	220	220	220	220	210
MAX. POWER	[kW]	245	245	245	245	245	245	245	235
MAX. CASE PRESSURE	[bar]	6	6	6	6	6	6	6	6
DRY WEIGHT	[kg]	308	308	308	308	308	308	308	308
TEMPERATURE RANGE (**)	[°C]	-30÷70	-30÷70	-30÷70	-30÷70	-30÷70	-30÷70	-30÷70	-30÷70

- (*) The standard distributor (D90) is shown. Please refer to distributors section (pag. 174-175) for different distributor interfaces.

- (**) Please refer to the hydraulic fluid recommendations (pag. 10-11).

- (***) Do not exceed maximum power (see pag. 13).

- (****) For motor operation with a continuous duty cycle at maximum continuous power the flushing is usually required. For more information please contact our technical department.

SHAFTS

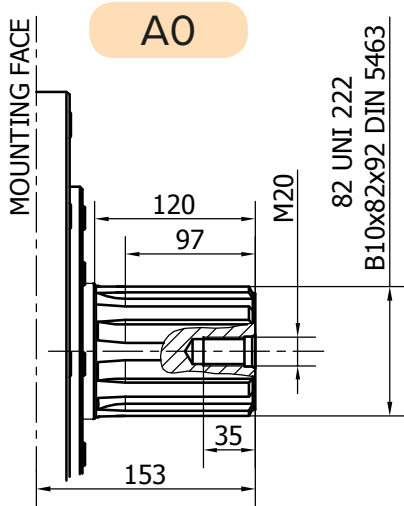

Available spline billet: SB9

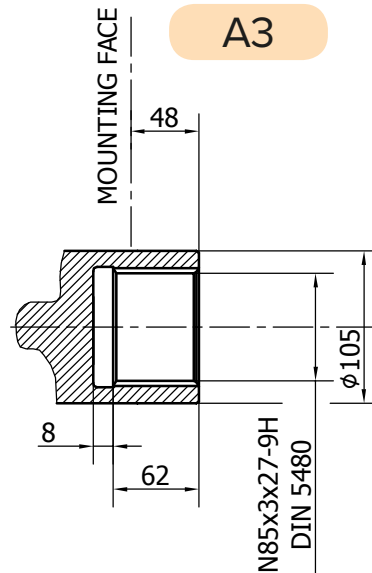
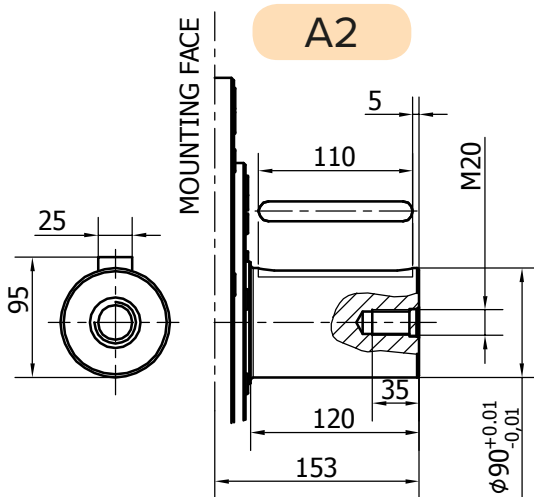
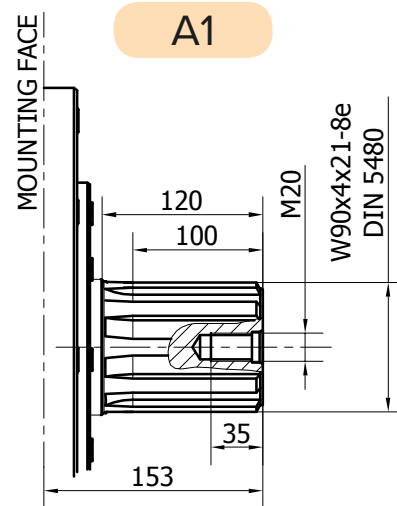

R8D 2200/B125-2500/B150-3000/B200 H6

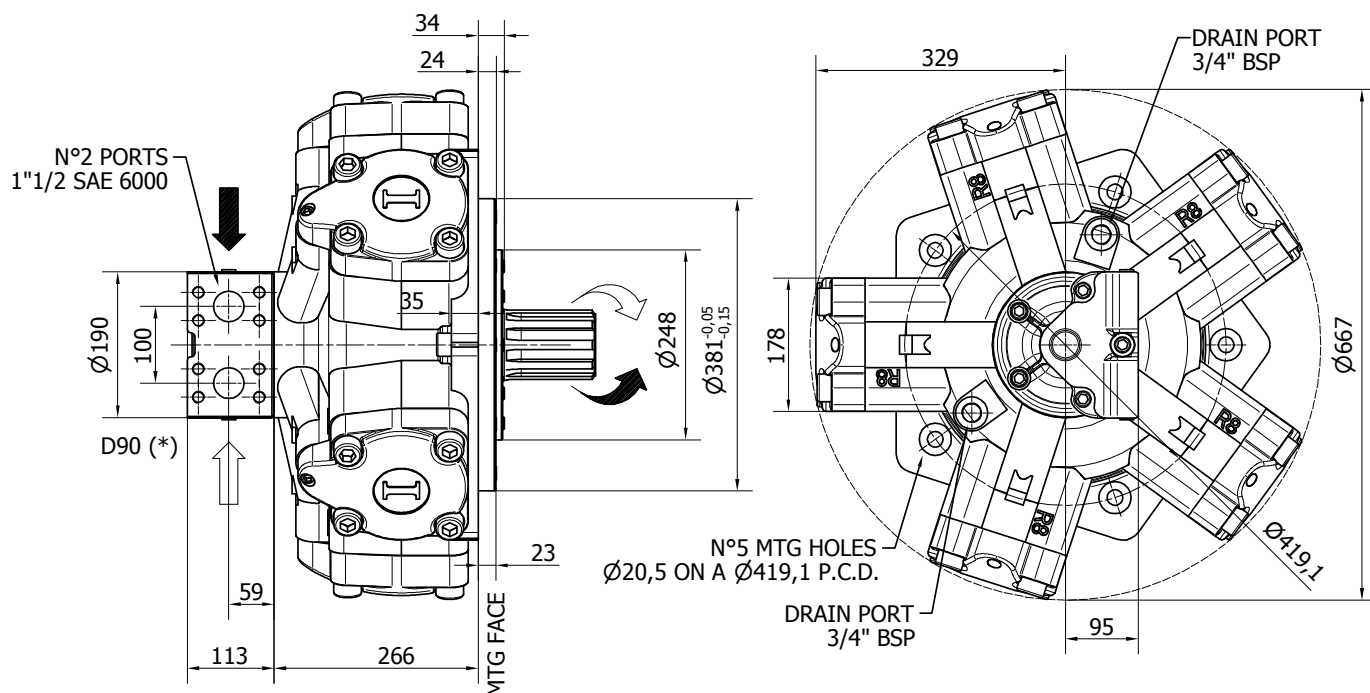

Available distributor flange: **FL7**

For S04, refer to page 186-187
(distributor fitting D90)

TECHNICAL DATA

		2200	2500	3000
DISPLACEMENT	[cc]	2206	2525	2983
SPECIFIC TORQUE	[Nm/bar]	35.1	40.2	47.5
MAX. CONT. PRESSURE	[bar]	270	270	270
HYDROSTATIC TEST PRESSURE	[bar]	420	420	420
MAX. CONT. SPEED	[rpm]	325	285	235
PEAK SPEED (**)	[rpm]	375	325	270
MAX. CONT. POWER (***)	[kW]	220	220	220
MAX. POWER	[kW]	245	245	245
MAX. CASE PRESSURE	[bar]	6	6	6
DRY WEIGHT	[kg]	308	308	308
TEMPERATURE RANGE (**)	[°C]	-30÷70	-30÷70	-30÷70

- (*) The standard distributor (D90) is shown. Please refer to distributors section (pag. 174-175) for different distributor interfaces.

- (**) Please refer to the hydraulic fluid recommendations (pag. 10-11).

- (***) Do not exceed maximum power (see pag. 13).

- (****) For motor operation with a continuous duty cycle at maximum continuous power the flushing is usually required. For more information please contact our technical department.

SHAFTS

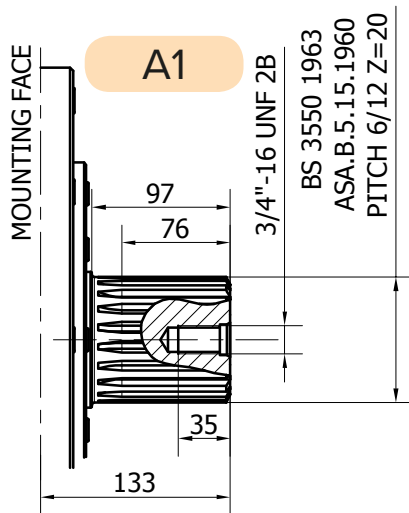

Available spline billet: **SB10**

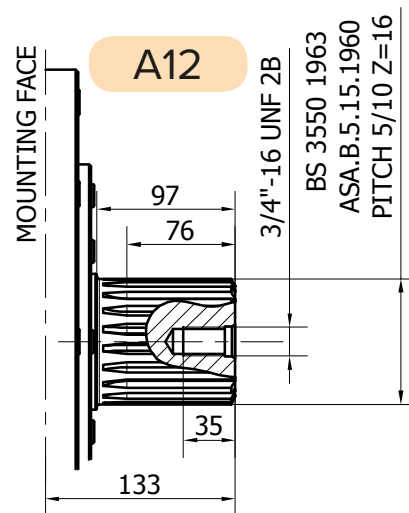

Available spline billet: **SB27**

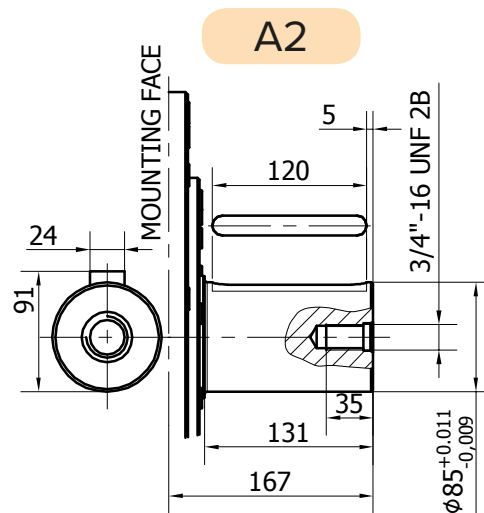

R8D H6/GM6

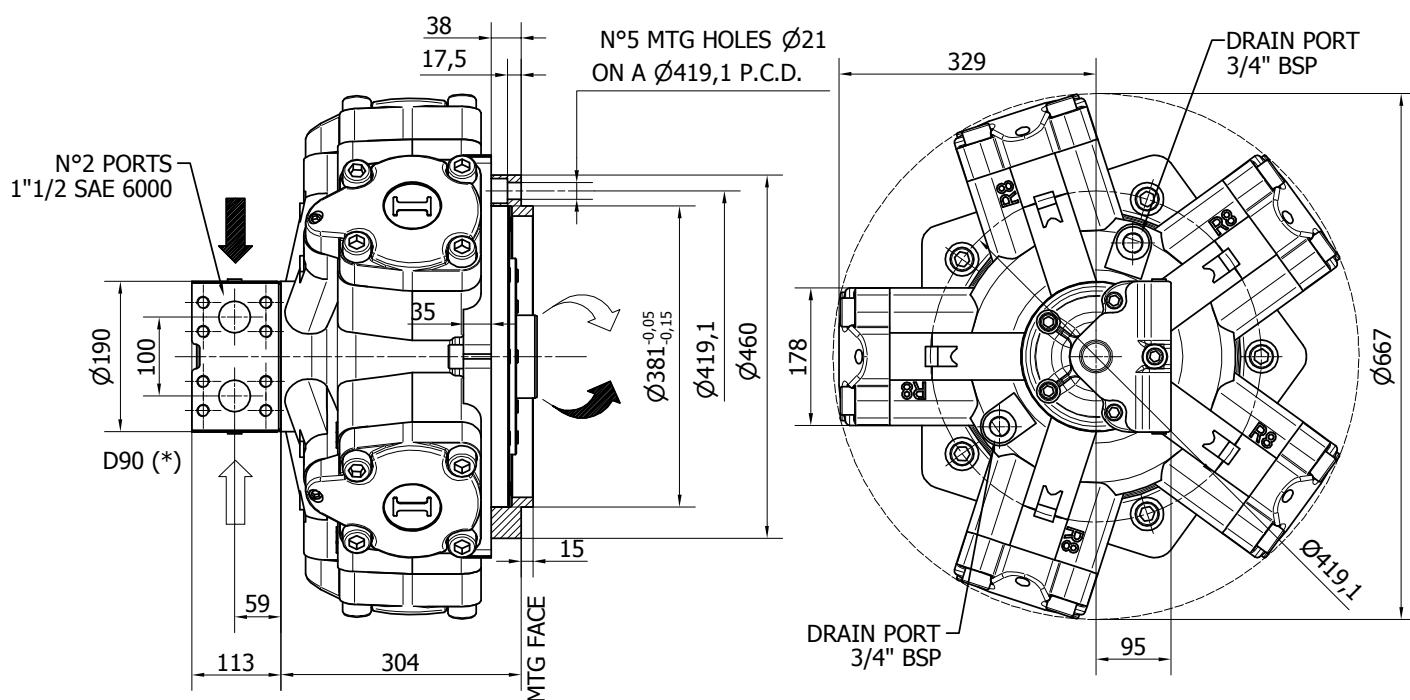

Available distributor flange: **FL7**

For S04, refer to page 186-187
(distributor fitting D90)

TECHNICAL DATA

		1800	2000	2200	2500	2800	3000	3200	3500
DISPLACEMENT	[cc]	1866	1993	2206	2525	2807	2983	3289	3479
SPECIFIC TORQUE	[Nm/bar]	29.7	31.7	35.1	40.2	44.7	47.5	52.4	55.4
MAX. CONT. PRESSURE	[bar]	270	270	270	270	270	270	270	270
HYDROSTATIC TEST PRESSURE	[bar]	420	420	420	420	420	420	420	420
MAX. CONT. SPEED	[rpm]	350	350	325	285	250	235	210	200
PEAK SPEED (**)	[rpm]	400	400	375	325	290	270	240	230
MAX. CONT. POWER (***)	[kW]	220	220	220	220	220	220	220	210
MAX. POWER	[kW]	245	245	245	245	245	245	245	235
MAX. CASE PRESSURE	[bar]	6	6	6	6	6	6	6	6
DRY WEIGHT	[kg]	308	308	308	308	308	308	308	308
TEMPERATURE RANGE (**)	[°C]	-30÷70	-30÷70	-30÷70	-30÷70	-30÷70	-30÷70	-30÷70	-30÷70

- (*) The standard distributor (D90) is shown. Please refer to distributors section (pag. 174-175) for different distributor interfaces.

- (***) Please refer to the hydraulic fluid recommendations (pag. 10-11).

- (****) Do not exceed maximum power (see pag. 13).

- (*****) For motor operation with a continuous duty cycle at maximum continuous power the flushing is usually required. For more information please contact our technical department.

SHAFTS

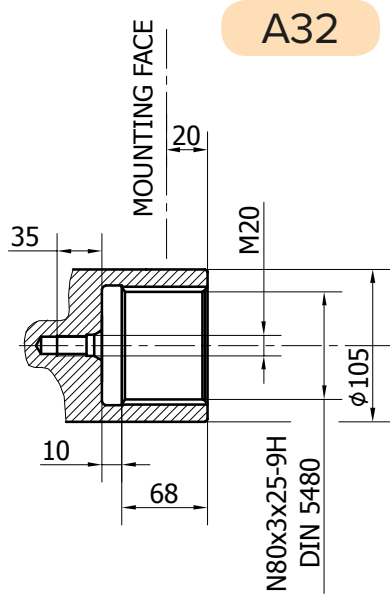

R8D H6/PL

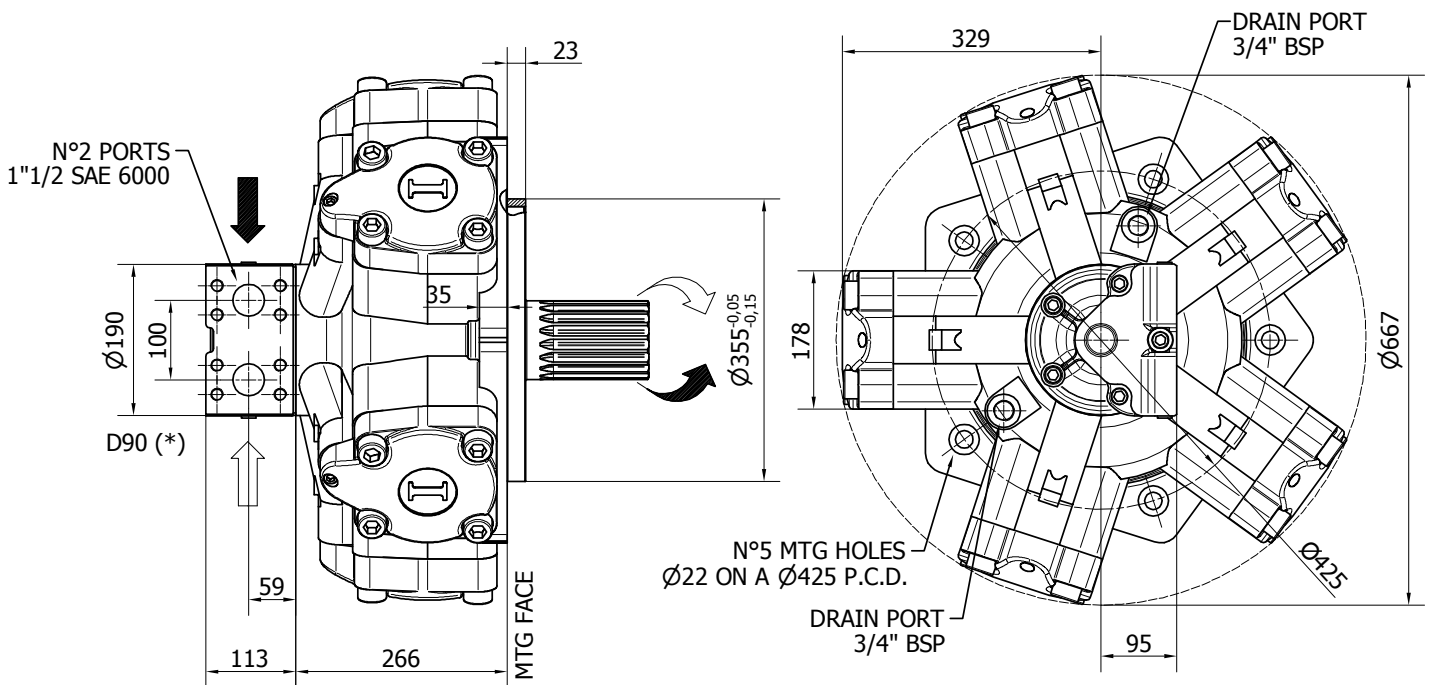

TECHNICAL DATA

		1800	2000	2200	2500	2800	3000	3200	3500
DISPLACEMENT	[cc]	1866	1993	2206	2525	2807	2983	3289	3479
SPECIFIC TORQUE	[Nm/bar]	29.7	31.7	35.1	40.2	44.7	47.5	52.4	55.4
MAX. CONT. PRESSURE	[bar]	270	270	270	270	270	270	270	270
HYDROSTATIC TEST PRESSURE	[bar]	420	420	420	420	420	420	420	420
MAX. CONT. SPEED	[rpm]	350	350	325	285	250	235	210	200
PEAK SPEED (**)	[rpm]	400	400	375	325	290	270	240	230
MAX. CONT. POWER (***)	[kW]	220	220	220	220	220	220	220	210
MAX. POWER	[kW]	245	245	245	245	245	245	245	235
MAX. CASE PRESSURE	[bar]	6	6	6	6	6	6	6	6
DRY WEIGHT	[kg]	308	308	308	308	308	308	308	308
TEMPERATURE RANGE (**)	[°C]	-30÷70	-30÷70	-30÷70	-30÷70	-30÷70	-30÷70	-30÷70	-30÷70

- (*) The standard distributor (D90) is shown. Please refer to distributors section (pag. 174-175) for different distributor interfaces.

- (***) Please refer to the hydraulic fluid recommendations (pag. 10-11).

- (****) Do not exceed maximum power (see pag. 13).

- (*****) For motor operation with a continuous duty cycle at maximum continuous power the flushing is usually required. For more information please contact our technical department.

SHAFTS

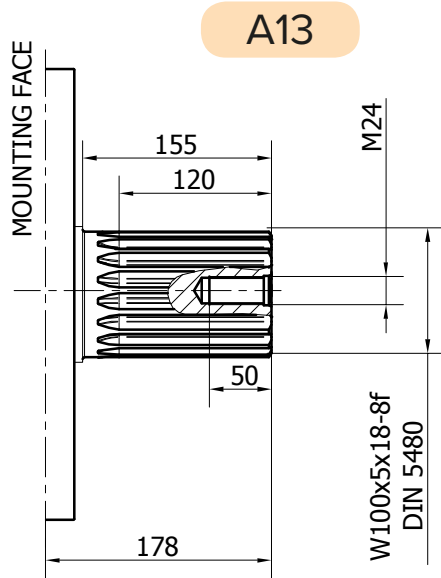

R8D H6 - PERFORMANCE CURVES

R8D 1800 H6

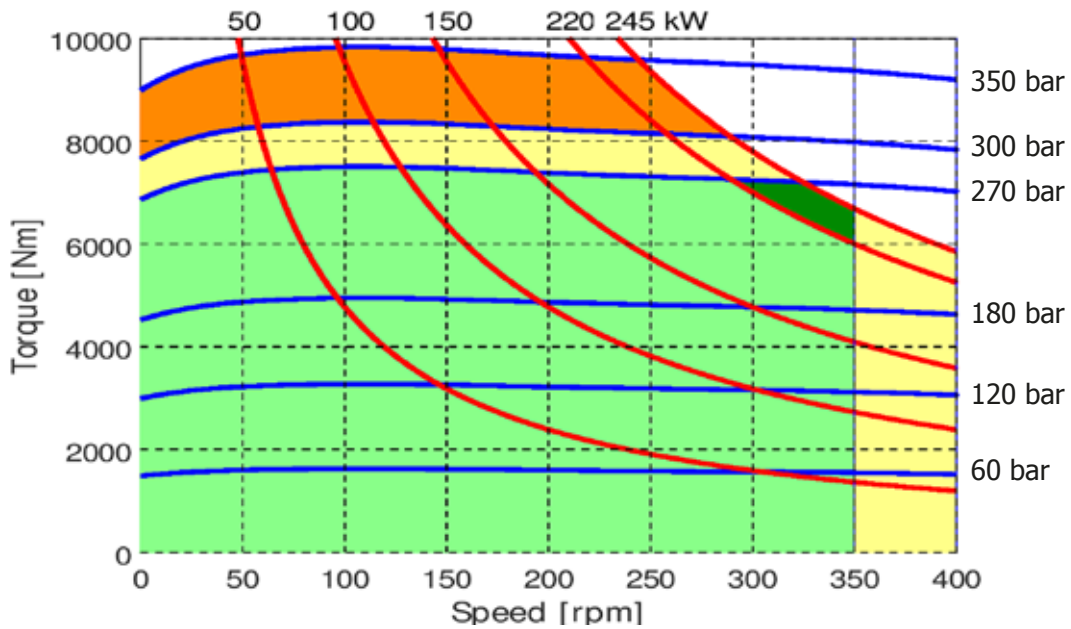

R8D 2000 H6

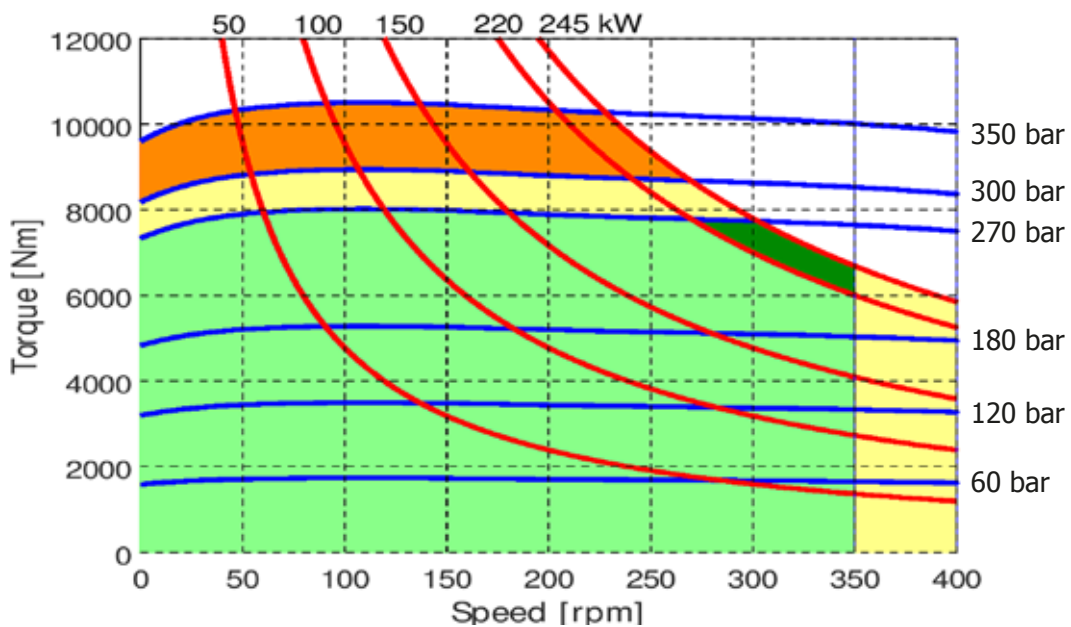

- Continuous operation
- Continuous operation with flushing or intermittent operation (see below for intermittent operation)
- Intermittent operation: permitted for a 15% of duty cycle, for 3 minutes maximum period
- Peak operation: permitted for very short periods (3-5 seconds every 10-15 minutes)

The above diagrams are referring to the hydraulic motor working with a fluid in ideal conditions (viscosity at 40 cSt). In case the working temperature increases and viscosity reach values under the recommended values (see hydraulic fluid recommendations) flushing must be performed or ISO oil grade must be changed. The working temperature must not overcome 70 °C.

R8D 2200 H6

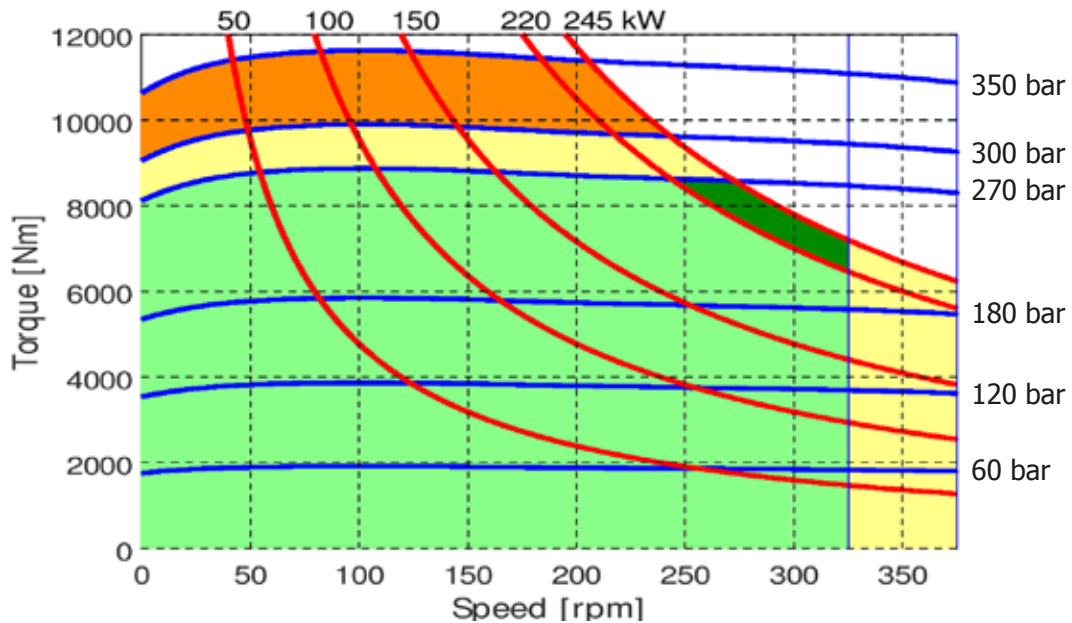

R8D 2500 H6

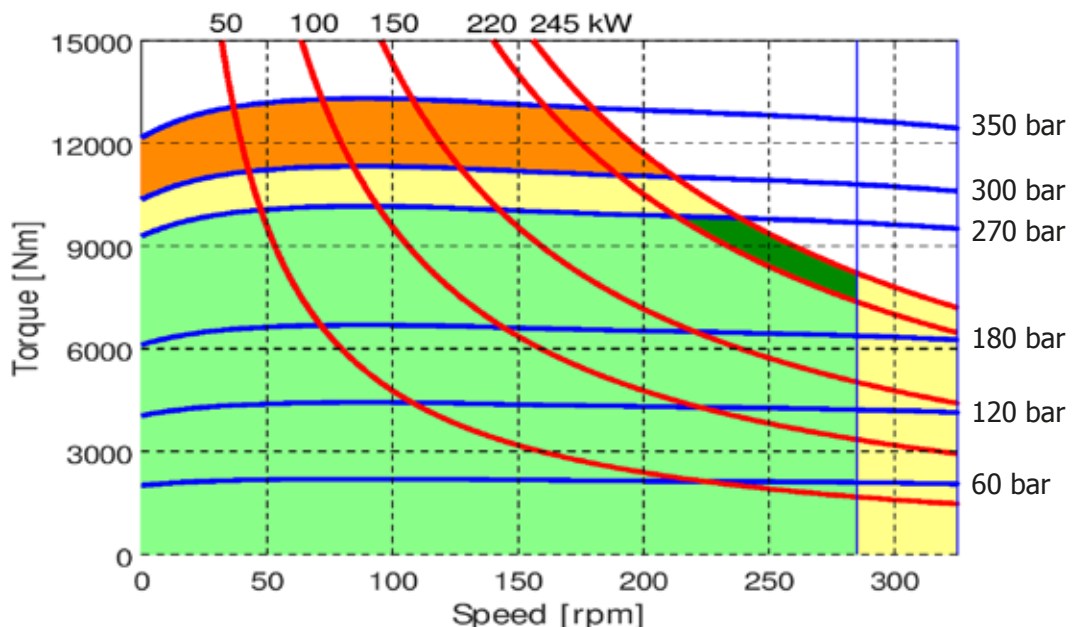

- Continuous operation
- Continuous operation with flushing or intermittent operation (see below for intermittent operation)
- Intermittent operation: permitted for a 15% of duty cycle, for 3 minutes maximum period
- Peak operation: permitted for very short periods (3-5 seconds every 10-15 minutes)

The above diagrams are referring to the hydraulic motor working with a fluid in ideal conditions (viscosity at 40 cSt). In case the working temperature increases and viscosity reach values under the recommended values (see hydraulic fluid recommendations) flushing must be performed or ISO oil grade must be changed. The working temperature must not overcome 70 °C.

R8D H6 - PERFORMANCE CURVES

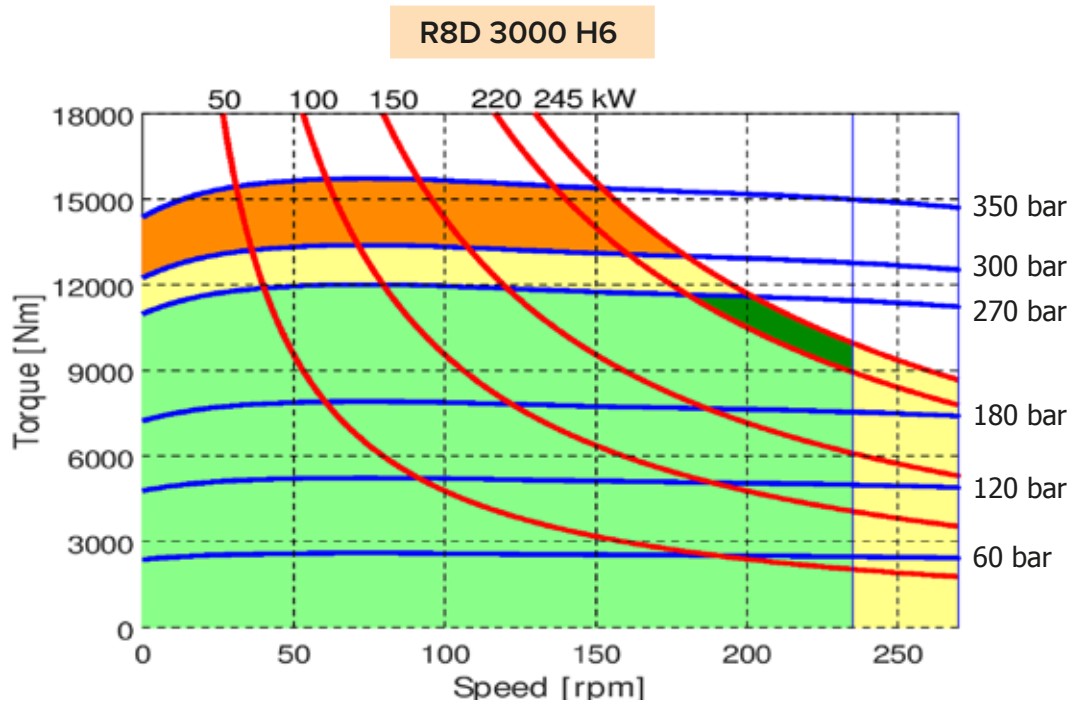
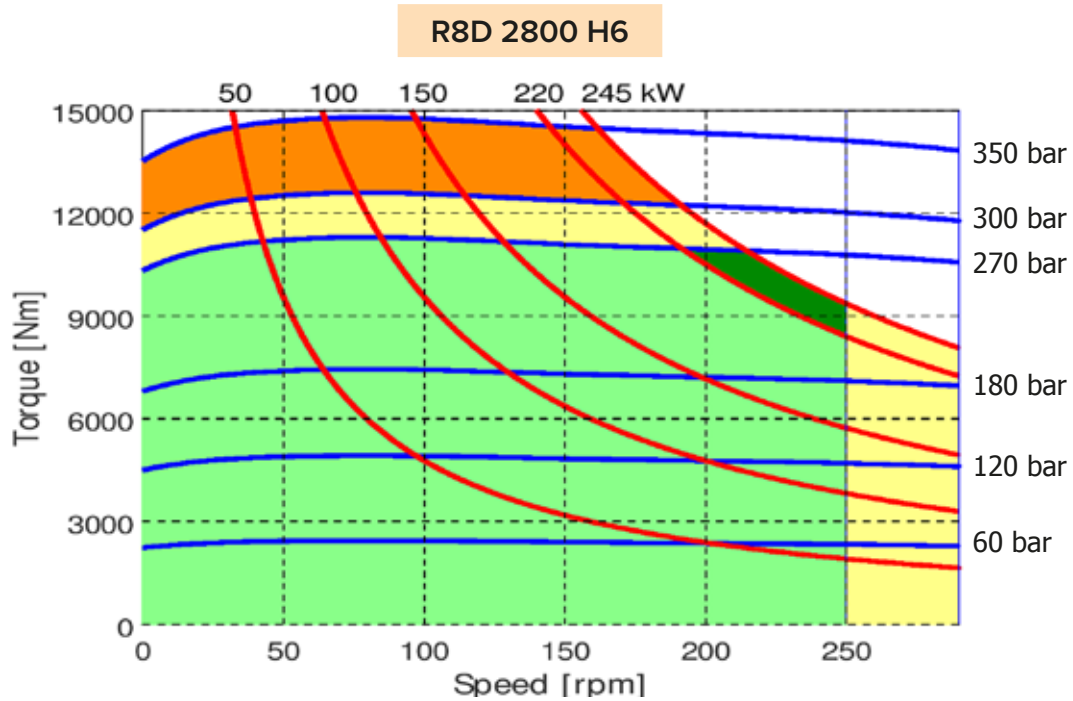

- Continuous operation
- Continuous operation with flushing or intermittent operation (see below for intermittent operation)
- Intermittent operation: permitted for a 15% of duty cycle, for 3 minutes maximum period
- Peak operation: permitted for very short periods (3-5 seconds every 10-15 minutes)

The above diagrams are referring to the hydraulic motor working with a fluid in ideal conditions (viscosity at 40 cSt). In case the working temperature increases and viscosity reach values under the recommended values (see hydraulic fluid recommendations) flushing must be performed or ISO oil grade must be changed. The working temperature must not overcome 70 °C.

R8D 3200 H6

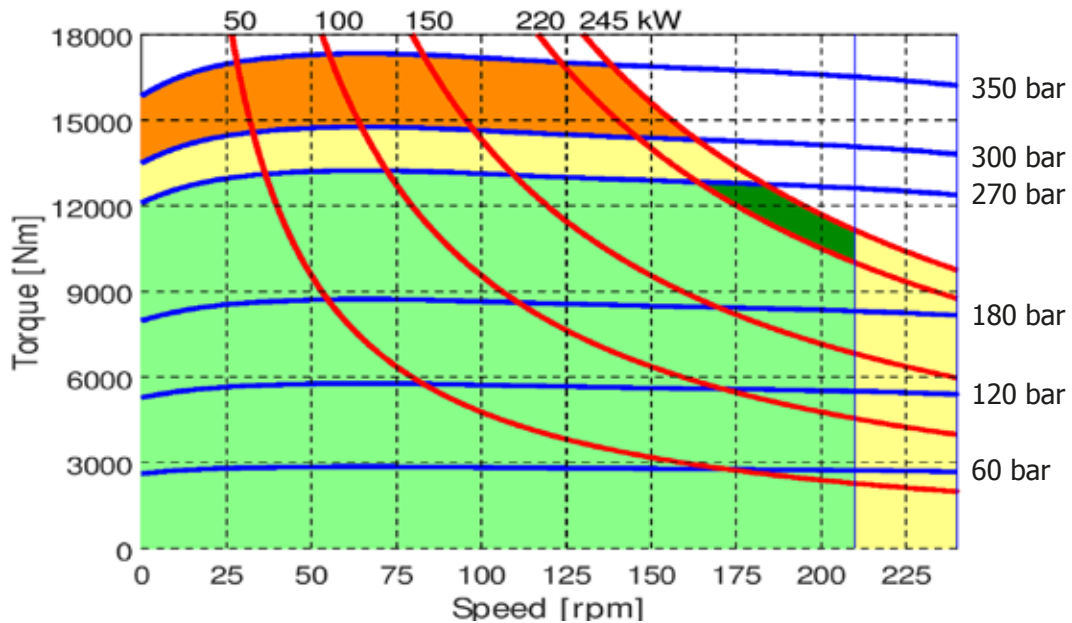

R8D 3500 H6

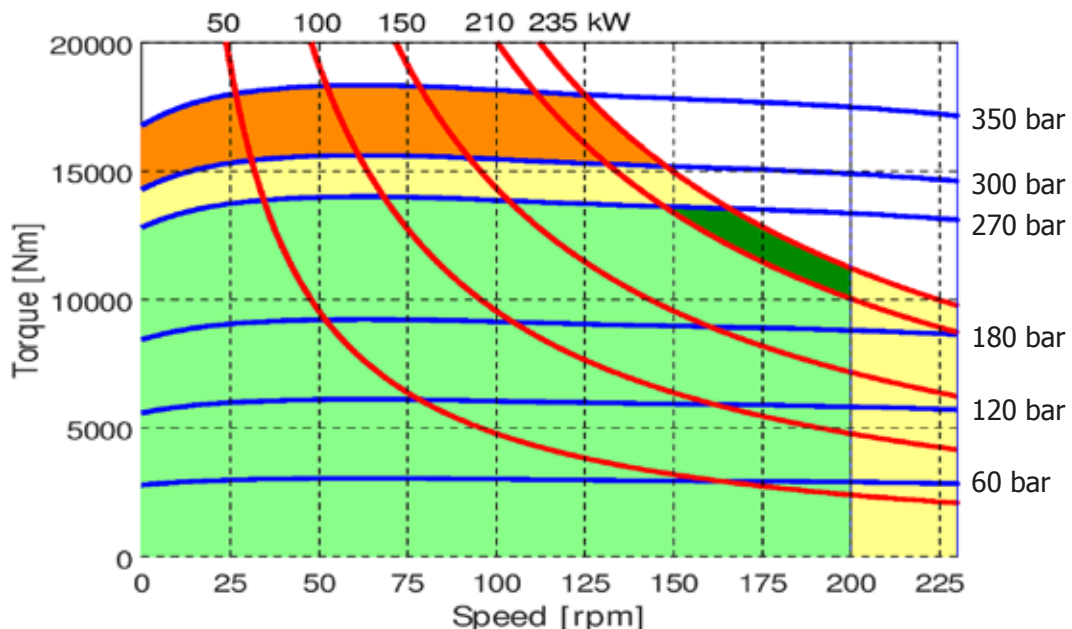

- Continuous operation
- Continuous operation with flushing or intermittent operation (see below for intermittent operation)
- Intermittent operation: permitted for a 15% of duty cycle, for 3 minutes maximum period
- Peak operation: permitted for very short periods (3-5 seconds every 10-15 minutes)

The above diagrams are referring to the hydraulic motor working with a fluid in ideal conditions (viscosity at 40 cSt). In case the working temperature increases and viscosity reach values under the recommended values (see hydraulic fluid recommendations) flushing must be performed or ISO oil grade must be changed. The working temperature must not overcome 70 °C.

R8D H6 - PERFORMANCE CURVES

CREEP SPEED - VOLUMETRIC EFFICIENCY

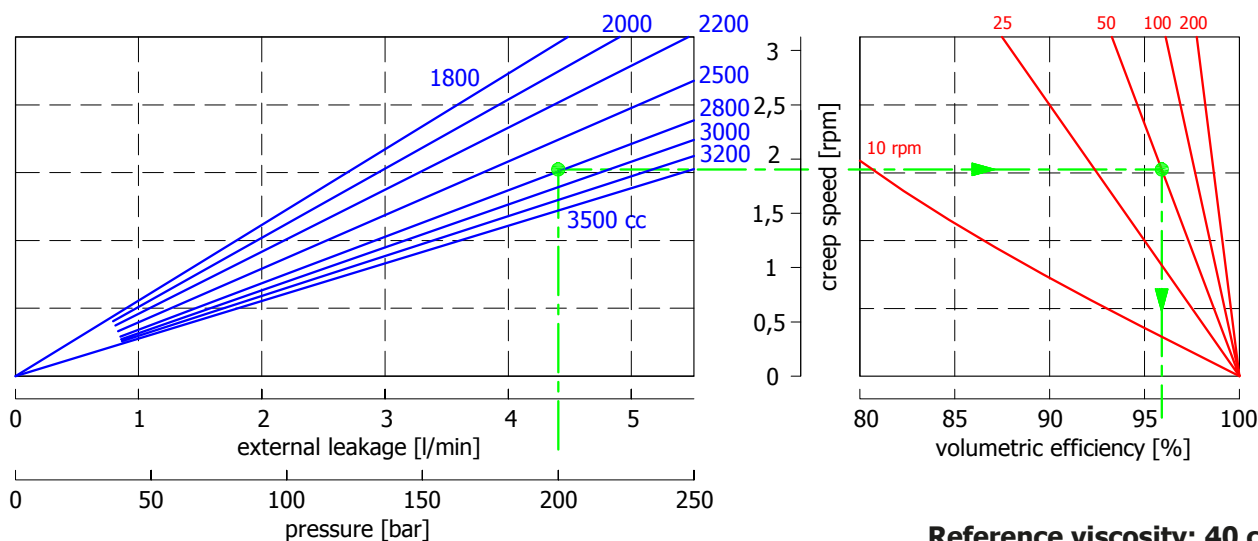

Reference viscosity: 40 cSt

Example:

We suppose (2800 cc): $p=200$ [bar], we obtain: external leakage 4,3 [l/min], shaft creep speed 1,9 [rpm].
 If we suppose (2800 cc): $p=200$ [bar] and $n=50$ [rpm] we obtain a volumetric efficiency of 96%;

BEARING LIFE

Reference displacement 3000 cc

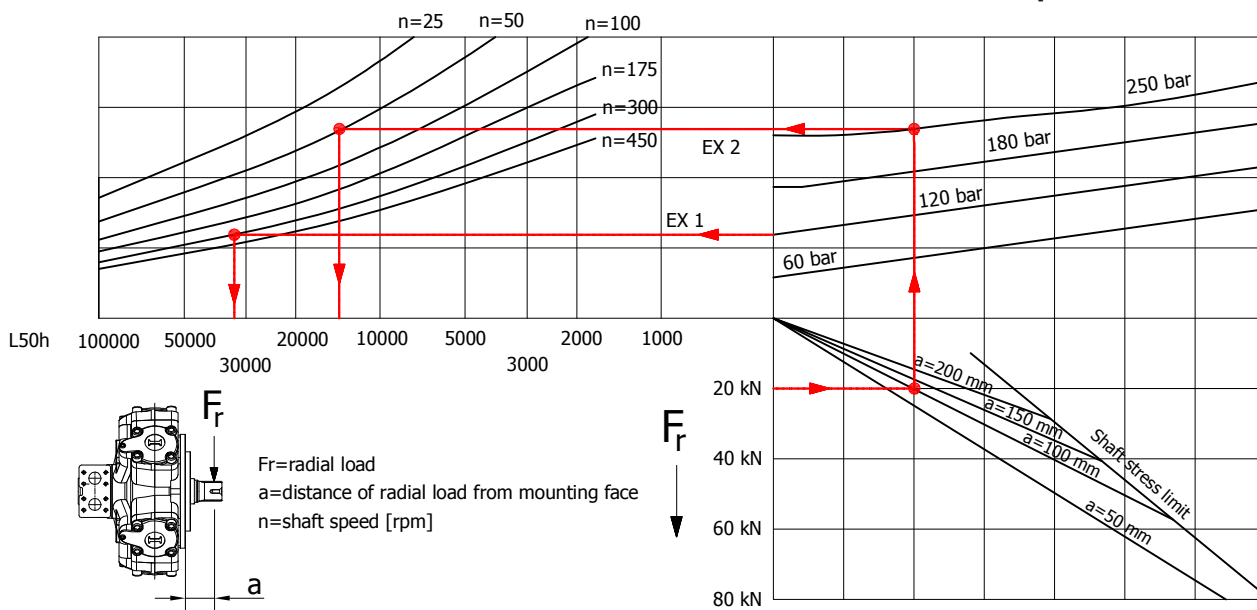

Reference viscosity: 40 cSt

Example:

We suppose (EX1): $p=120$ [bar], $n=300$ [rpm]; we obtain an average lifetime of 34000 [h].
 If we suppose (EX2): $F_r=20$ [kN], $a=100$ [mm], $n=50$ [rpm] and $p=250$ [bar] we obtain an average lifetime of 13000 [h].

R8D H6 - ORDERING CODE

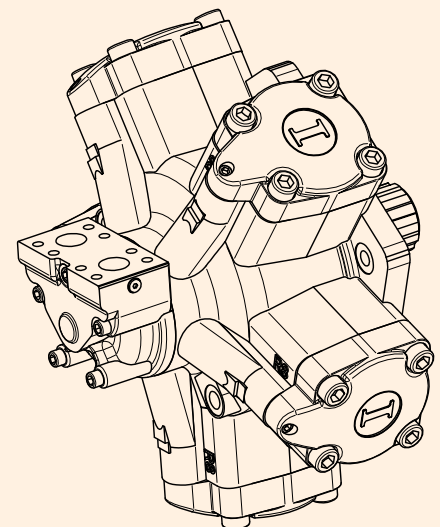
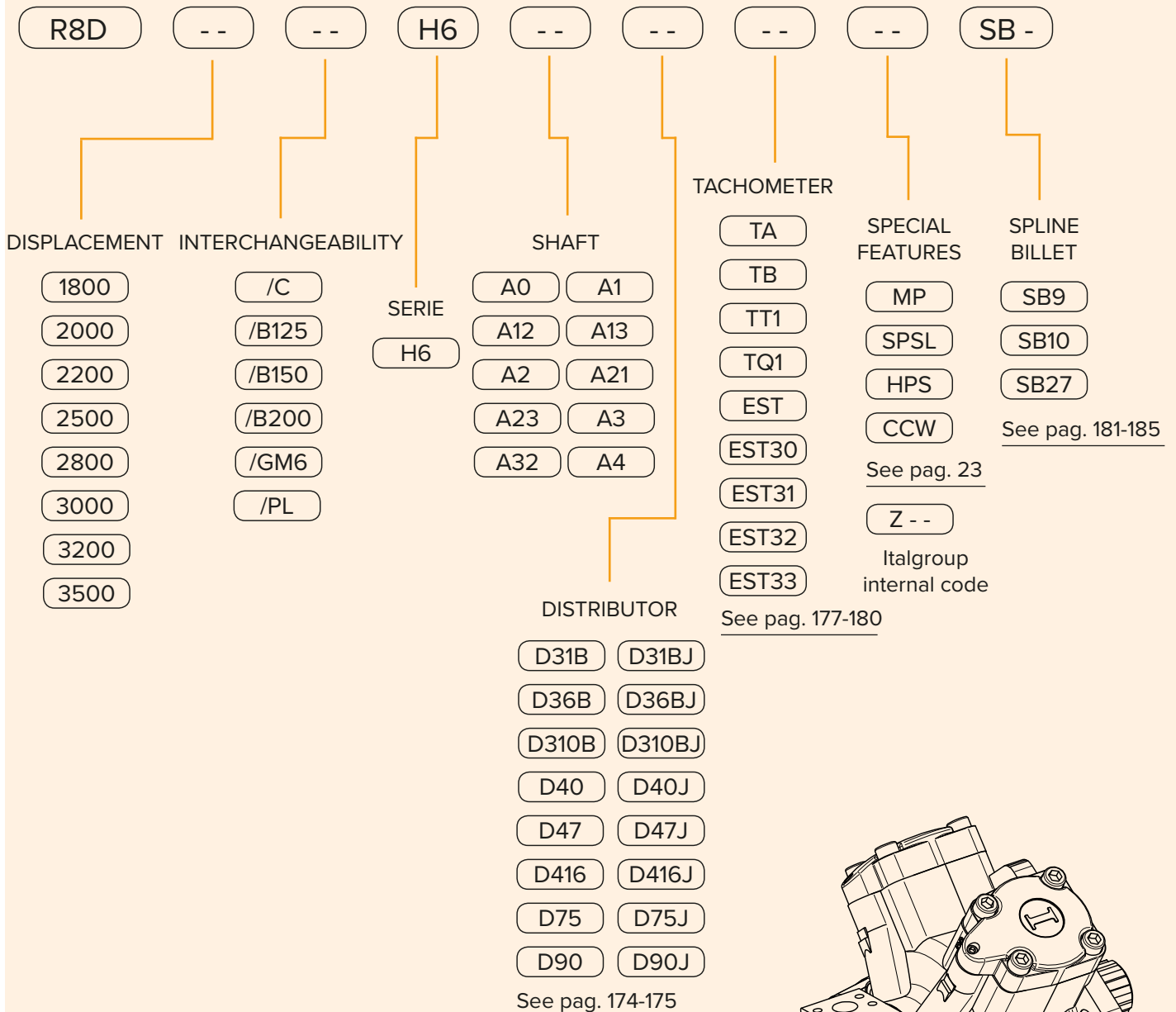

EXAMPLES:

R8D 2200 H6 A1 D90J
R8D 3000 H6 A0 D90 SB9
R8D 2500/C H6 A0 D90J CCW SB9

R8D H7

R8D H7	Pag. 136 - 139
R8D H7/C	Pag. 140 - 141
R8D H7/RM	Pag. 142 - 143
R8D H7 - PERFORMANCE CURVES	Pag. 144 - 148
R8D H7 - ORDERING CODE	Pag. 149

R8D H7

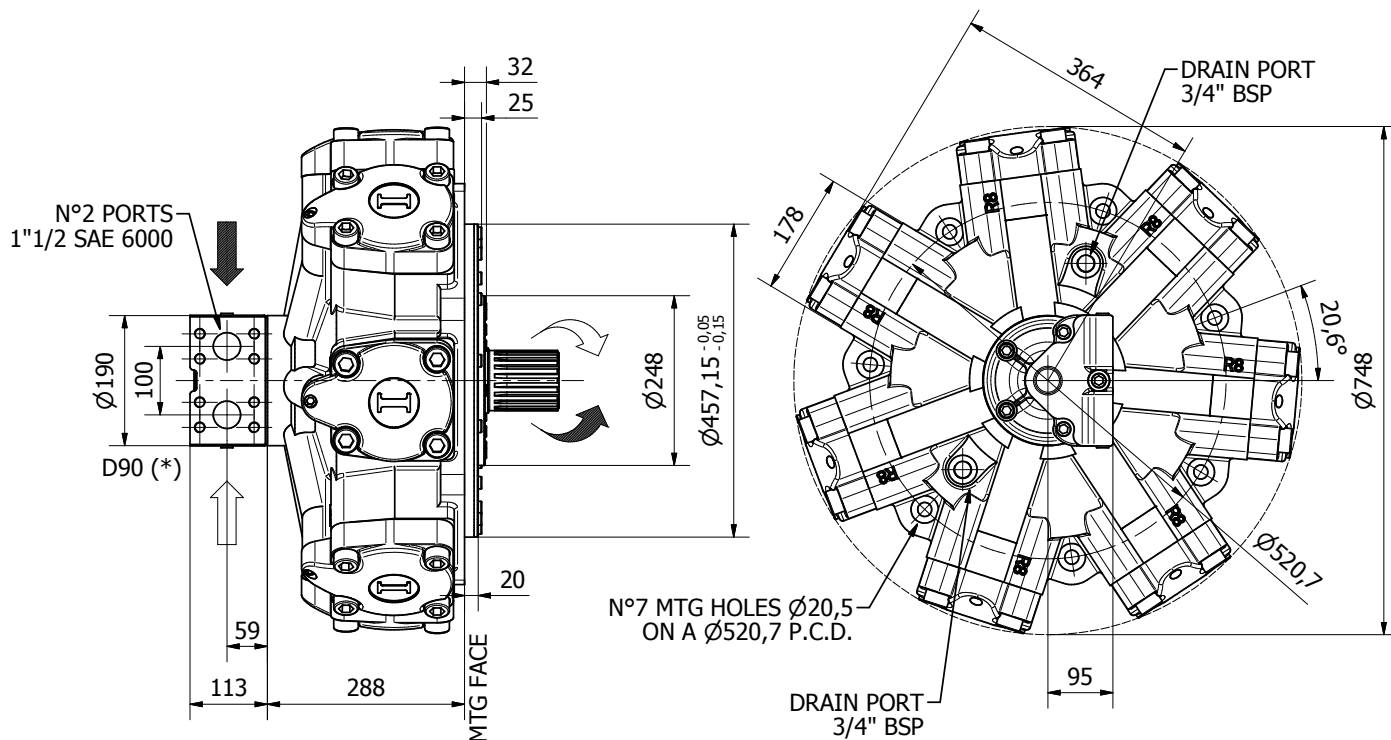

Available distributor flange: **FL16**

For S04, refer to page 186-187
(distributor fitting D90)

TECHNICAL DATA

		3400	3600	3900	4300	4600	5000	5400
DISPLACEMENT	[cc]	3413	3650	3907	4343	4616	5088	5384
SPECIFIC TORQUE	[Nm/bar]	54.3	58.1	62.2	69.1	73.5	81.0	85.7
MAX. CONT. PRESSURE	[bar]	270	270	270	270	270	270	270
HYDROSTATIC TEST PRESSURE	[bar]	420	420	420	420	420	420	420
MAX. CONT. SPEED	[rpm]	200	185	175	160	150	140	130
PEAK SPEED (**)	[rpm]	220	210	200	190	190	180	170
MAX. CONT. POWER (***)	[kW]	238	238	238	238	238	238	230
MAX. POWER	[kW]	265	265	265	265	265	265	258
MAX. CASE PRESSURE	[bar]	6	6	6	6	6	6	6
DRY WEIGHT	[kg]	405	405	405	405	405	405	405
TEMPERATURE RANGE (**)	[°C]	-30÷70	-30÷70	-30÷70	-30÷70	-30÷70	-30÷70	-30÷70

- (*) The standard distributor (D90) is shown. Please refer to distributors section (pag. 174-175) for different distributor interfaces.

- (**) Please refer to the hydraulic fluid recommendations (pag. 10-11).

- (***) Do not exceed maximum power (see pag. 13).

- (****) For motor operation with a continuous duty cycle at maximum continuous power the flushing is usually required. For more information please contact our technical department.

SHAFTS

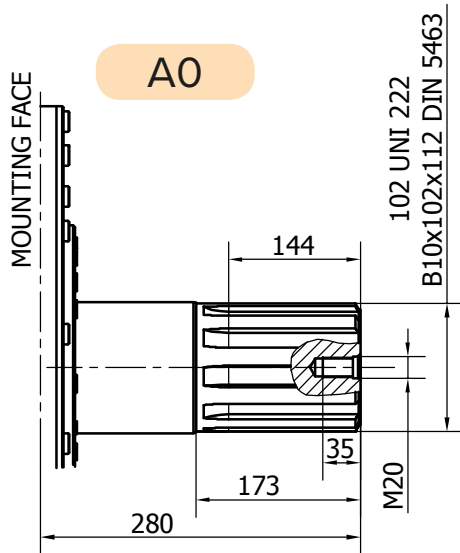

Available spline billet: SB11

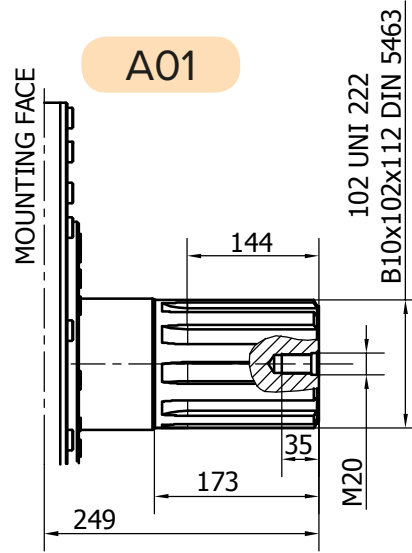

Available spline billet: SB11

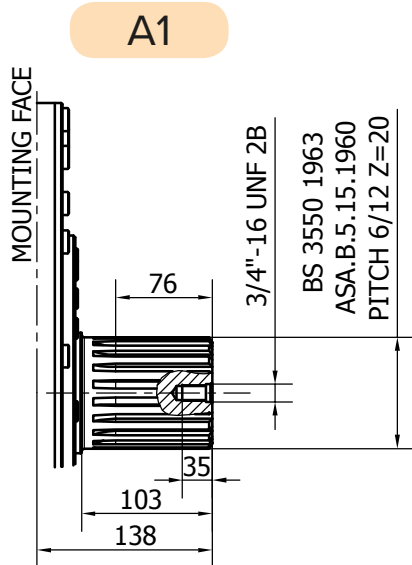

Available spline billet: SB10

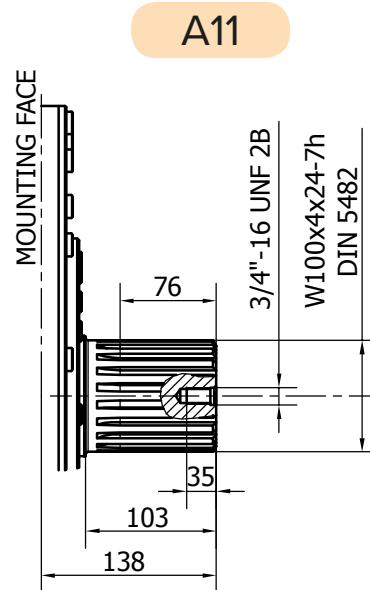

R8D H7

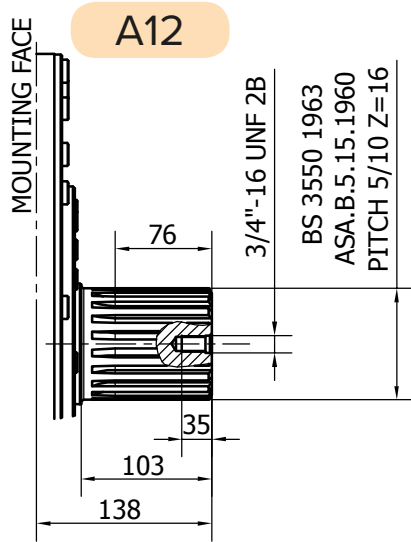

Available spline billet: SB27

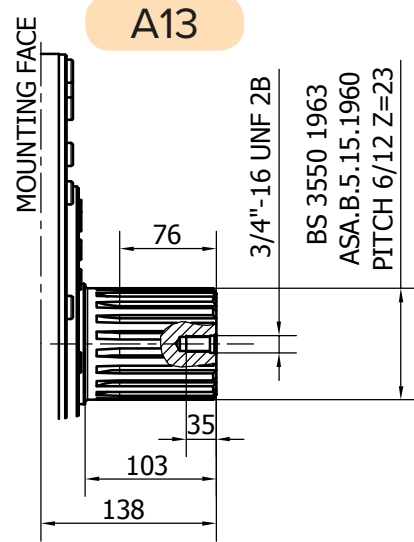

Available spline billet: SB24

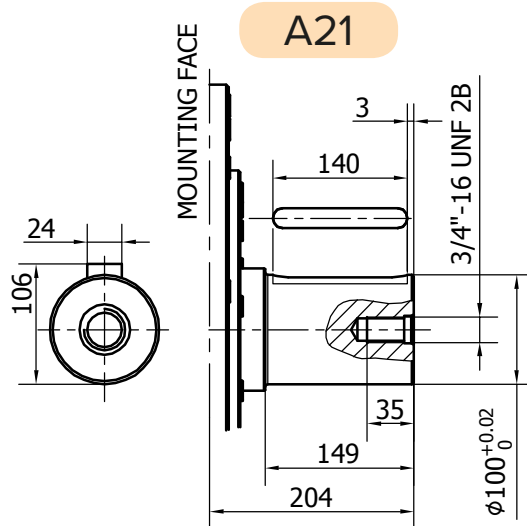
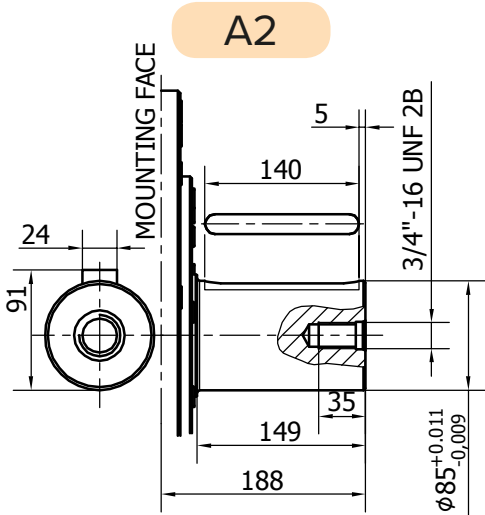

SHAFTS

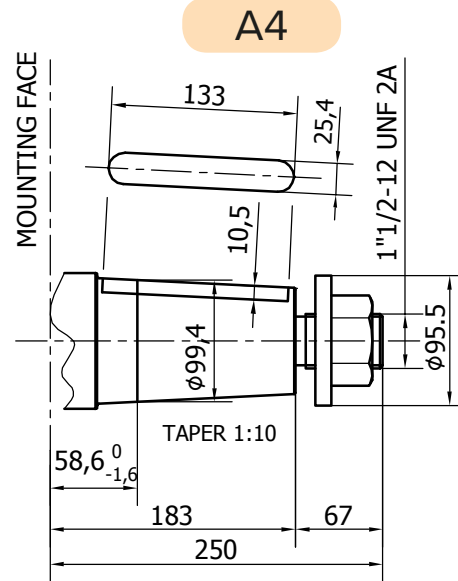
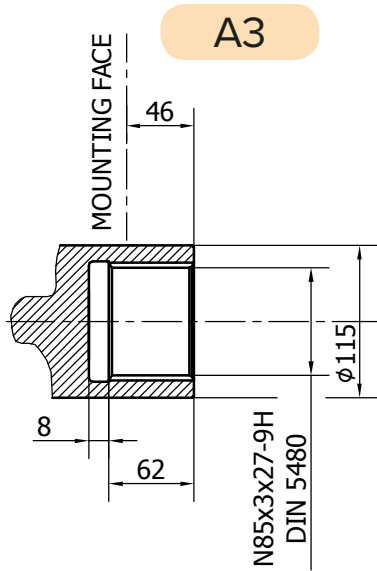

R8D H7/C

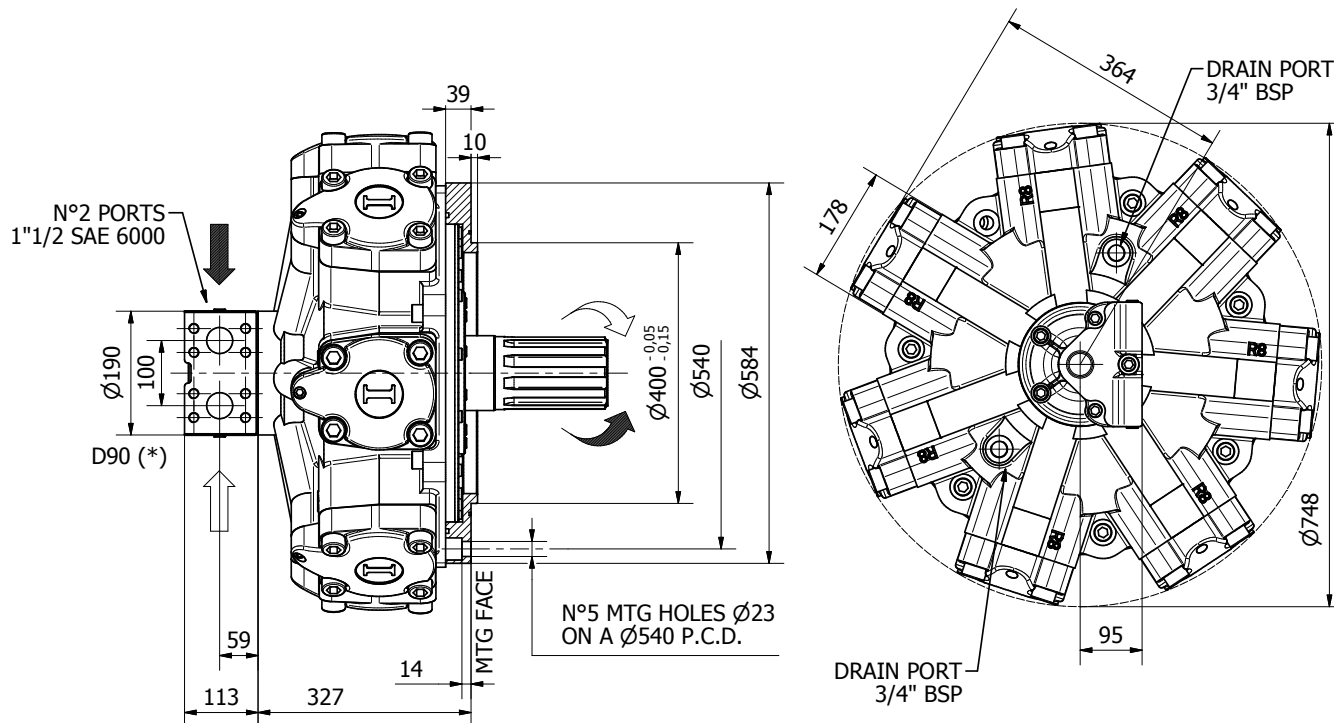

Available distributor flange: **FL8**

Refer to page 186-187
(distributor fitting D90)

TECHNICAL DATA

		3400	3600	3900	4300	4600	5000	5400
DISPLACEMENT	[cc]	3413	3650	3907	4343	4616	5088	5384
SPECIFIC TORQUE	[Nm/bar]	54.3	58.1	62.2	69.1	73.5	81.0	85.7
MAX. CONT. PRESSURE	[bar]	270	270	270	270	270	270	270
HYDROSTATIC TEST PRES-SURE	[bar]	420	420	420	420	420	420	420
MAX. CONT. SPEED	[rpm]	200	185	175	160	150	140	130
PEAK SPEED (**)	[rpm]	220	210	200	190	190	180	170
MAX. CONT. POWER (****)	[kW]	238	238	238	238	238	238	230
MAX. POWER	[kW]	265	265	265	265	265	265	258
MAX. CASE PRESSURE	[bar]	6	6	6	6	6	6	6
DRY WEIGHT	[kg]	405	405	405	405	405	405	405
TEMPERATURE RANGE (**)	[°C]	-30÷70	-30÷70	-30÷70	-30÷70	-30÷70	-30÷70	-30÷70

- (*) The standard distributor (D90) is shown. Please refer to distributors section (pag. 174-175) for different distributor interfaces.

- (**) Please refer to the hydraulic fluid recommendations (pag. 10-11).

- (***) Do not exceed maximum power (see pag. 13).

- (****) For motor operation with a continuous duty cycle at maximum continuous power the flushing is usually required. For more information please contact our technical department.

SHAFTS

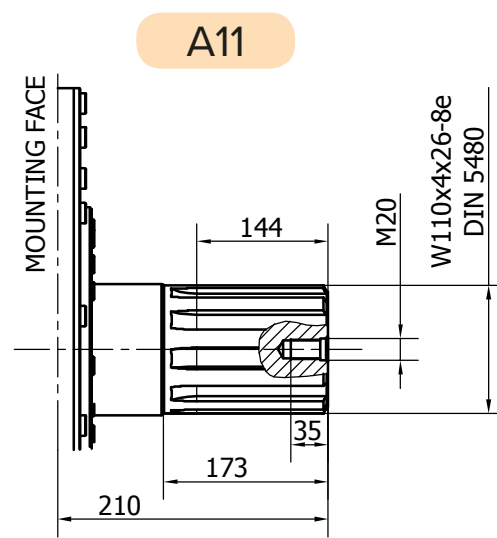
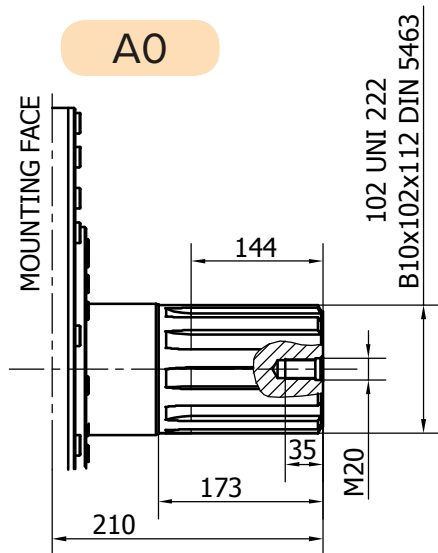

Available spline billet: SB11

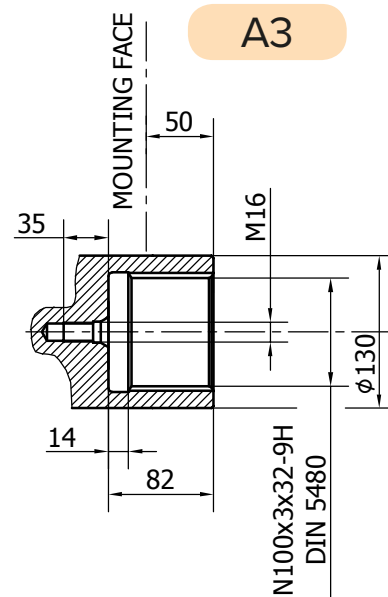
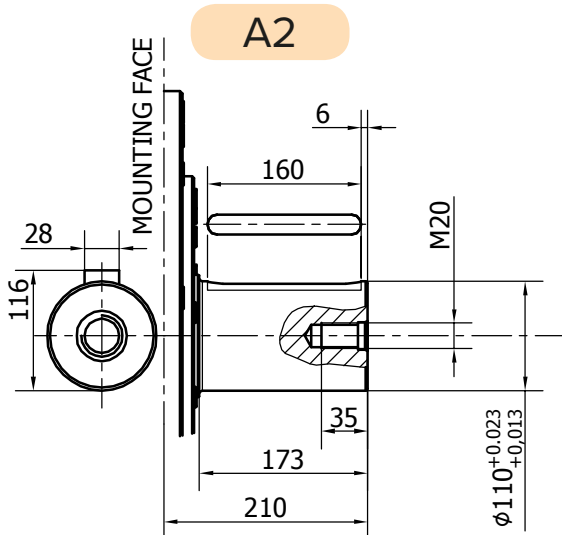

R8D H7/RM

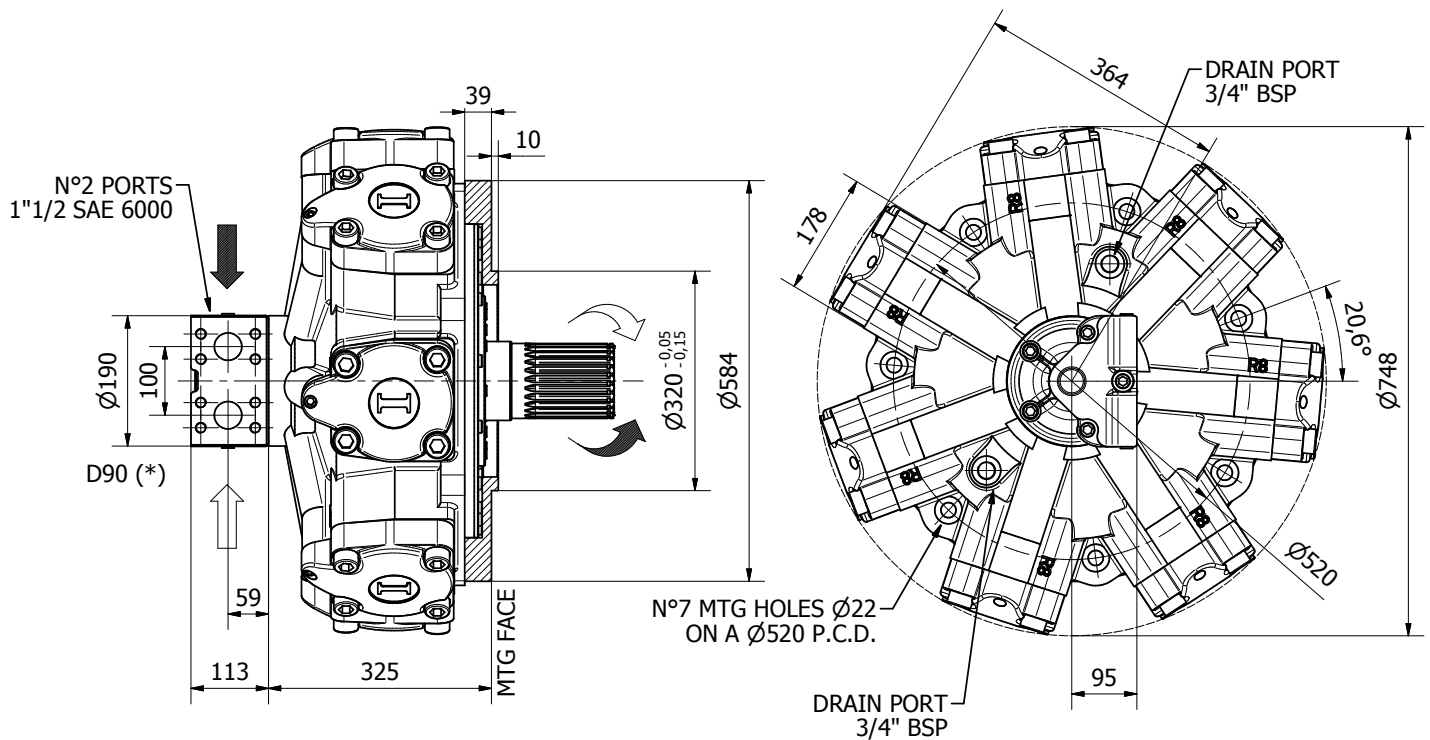

TECHNICAL DATA

		3400	3600	3900	4300	4600	5000	5400
DISPLACEMENT	[cc]	3413	3650	3907	4343	4616	5088	5384
SPECIFIC TORQUE	[Nm/bar]	54.3	58.1	62.2	69.1	73.5	81.0	85.7
MAX. CONT. PRESSURE	[bar]	270	270	270	270	270	270	270
HYDROSTATIC TEST PRESSURE	[bar]	420	420	420	420	420	420	420
MAX. CONT. SPEED	[rpm]	200	185	175	160	150	140	130
PEAK SPEED (***)	[rpm]	220	210	200	190	190	180	170
MAX. CONT. POWER (****)	[kW]	238	238	238	238	238	238	230
MAX. POWER	[kW]	265	265	265	265	265	265	258
MAX. CASE PRESSURE	[bar]	6	6	6	6	6	6	6
DRY WEIGHT	[kg]	405	405	405	405	405	405	405
TEMPERATURE RANGE (**)	[°C]	-30÷70	-30÷70	-30÷70	-30÷70	-30÷70	-30÷70	-30÷70

- (*) The standard distributor (D90) is shown. Please refer to distributors section (pag. 174-175) for different distributor interfaces.

- (**) Please refer to the hydraulic fluid recommendations (pag. 10-11).

- (***) Do not exceed maximum power (see pag. 13).

- (****) For motor operation with a continuous duty cycle at maximum continuous power the flushing is usually required. For more information please contact our technical department.

SHAFTS

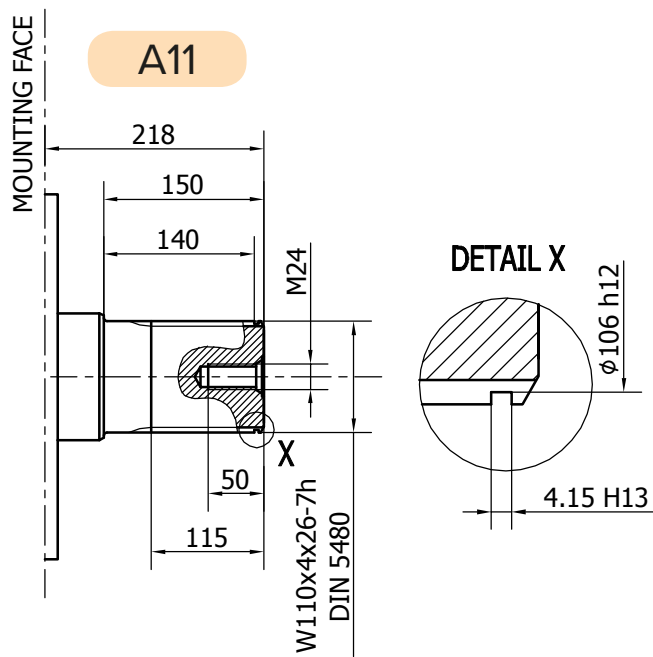

R8D H7 - PERFORMANCE CURVES

R8D 3400 H7

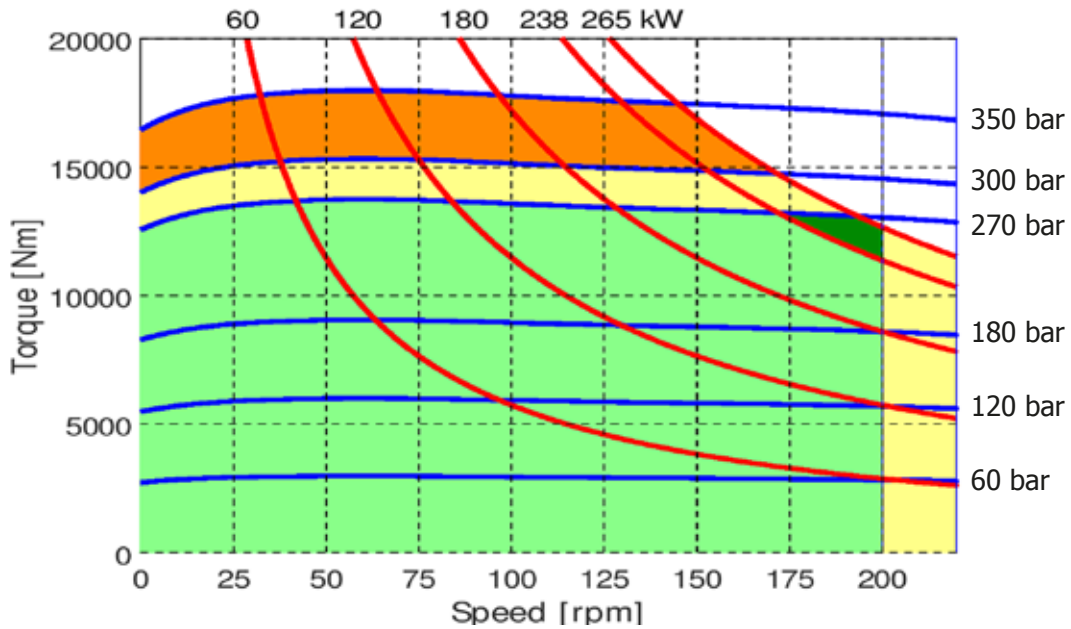

R8D 3600 H7

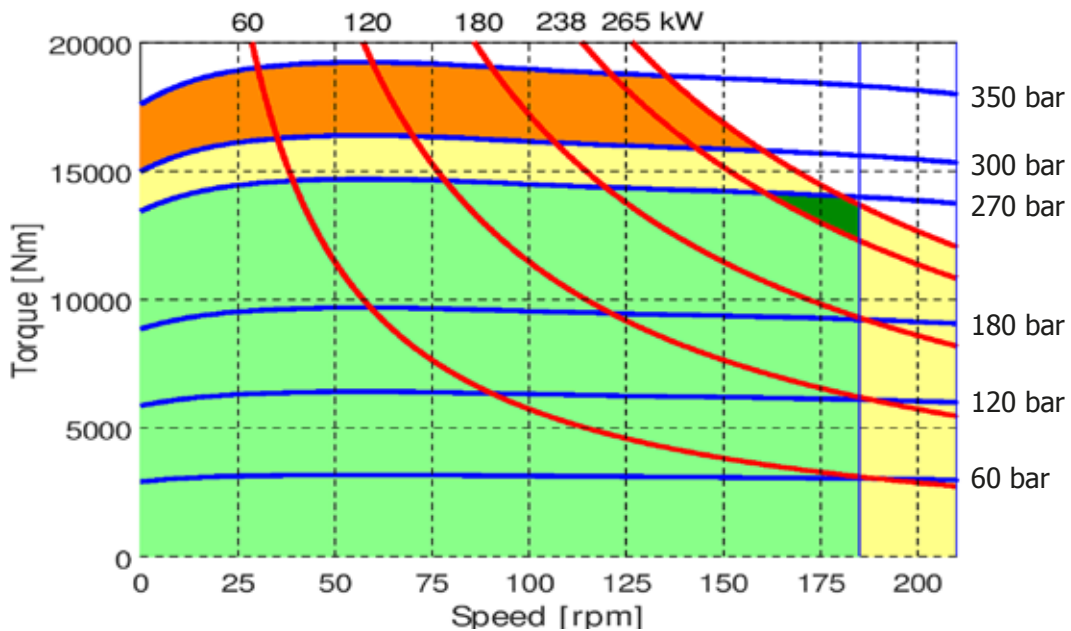

- Continuous operation
- Continuous operation with flushing or intermittent operation (see below for intermittent operation)
- Intermittent operation: permitted for a 15% of duty cycle, for 3 minutes maximum period
- Peak operation: permitted for very short periods (3-5 seconds every 10-15 minutes)

The above diagrams are referring to the hydraulic motor working with a fluid in ideal conditions (viscosity at 40 cSt). In case the working temperature increases and viscosity reach values under the recommended values (see hydraulic fluid recommendations) flushing must be performed or ISO oil grade must be changed. The working temperature must not overcome 70 °C.

R8D 3900 H7

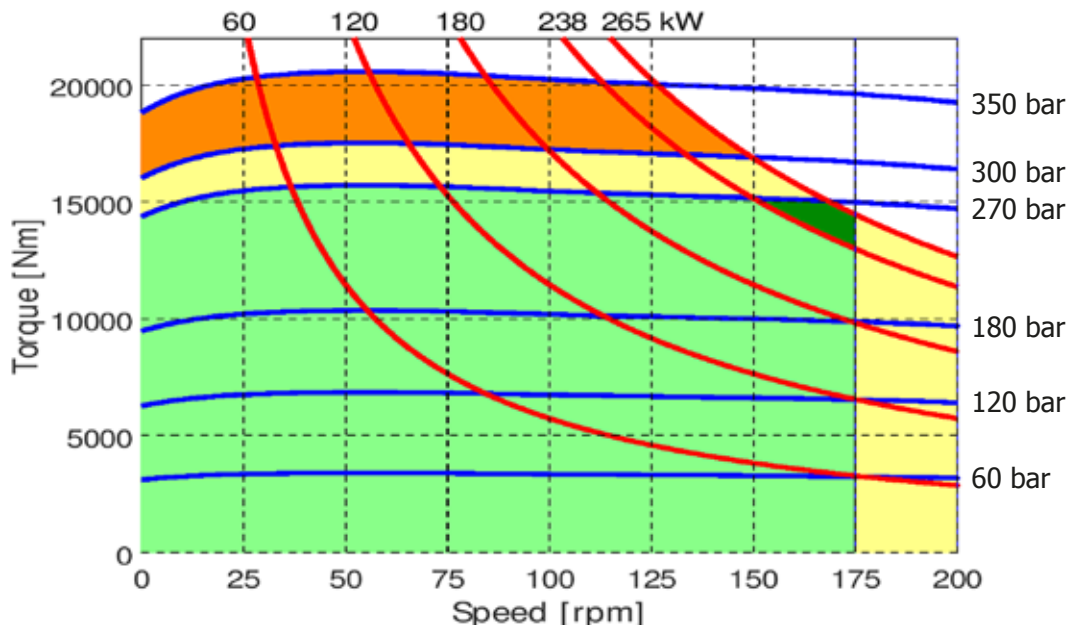

R8D 4300 H7

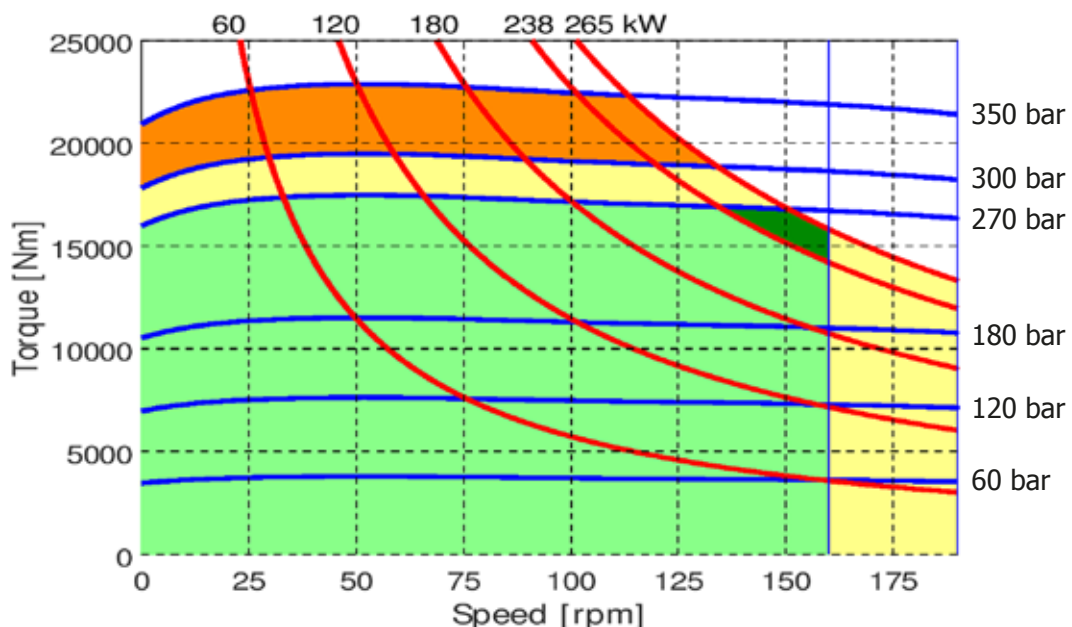

- Continuous operation
- Continuous operation with flushing or intermittent operation (see below for intermittent operation)
- Intermittent operation: permitted for a 15% of duty cycle, for 3 minutes maximum period
- Peak operation: permitted for very short periods (3-5 seconds every 10-15 minutes)

The above diagrams are referring to the hydraulic motor working with a fluid in ideal conditions (viscosity at 40 cSt). In case the working temperature increases and viscosity reach values under the recommended values (see hydraulic fluid recommendations) flushing must be performed or ISO oil grade must be changed. The working temperature must not overcome 70 °C.

R8D H7 - PERFORMANCE CURVES

R8D 4600 H7

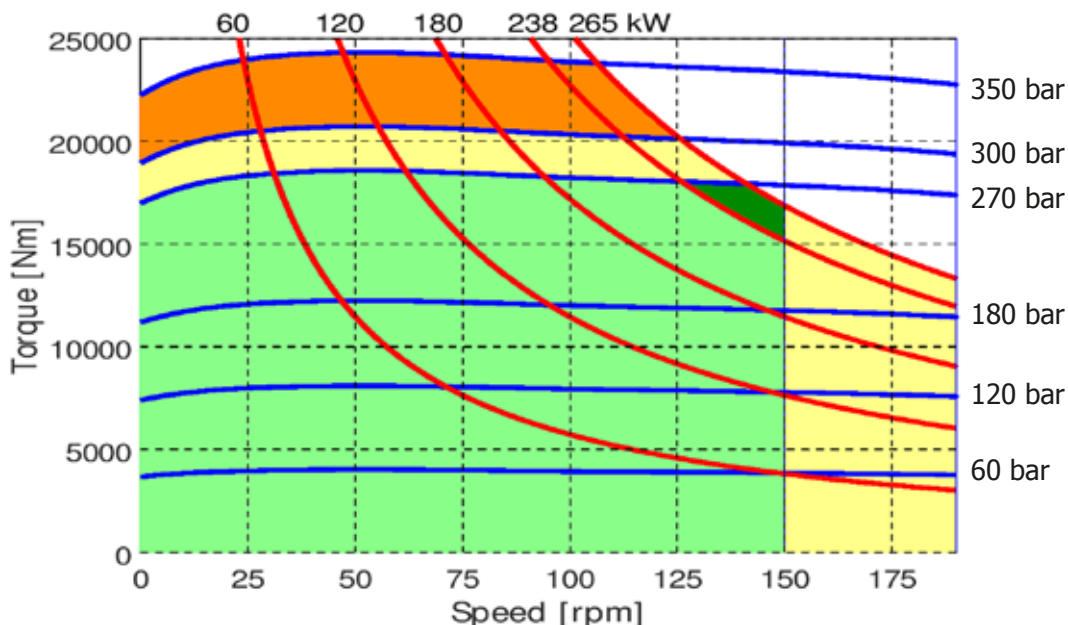

R8D 5000 H7

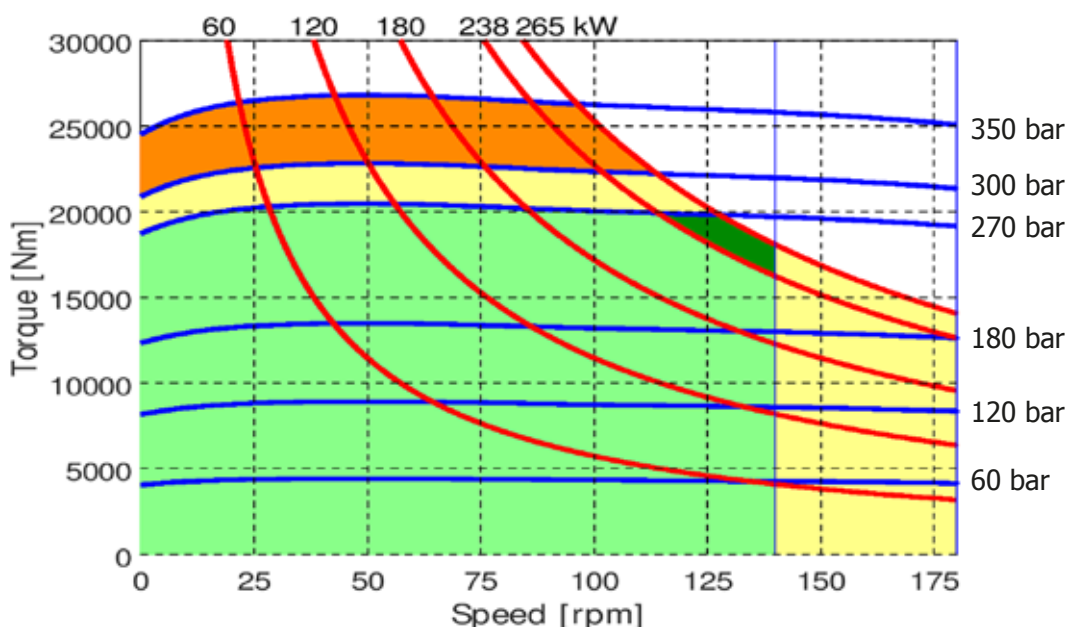



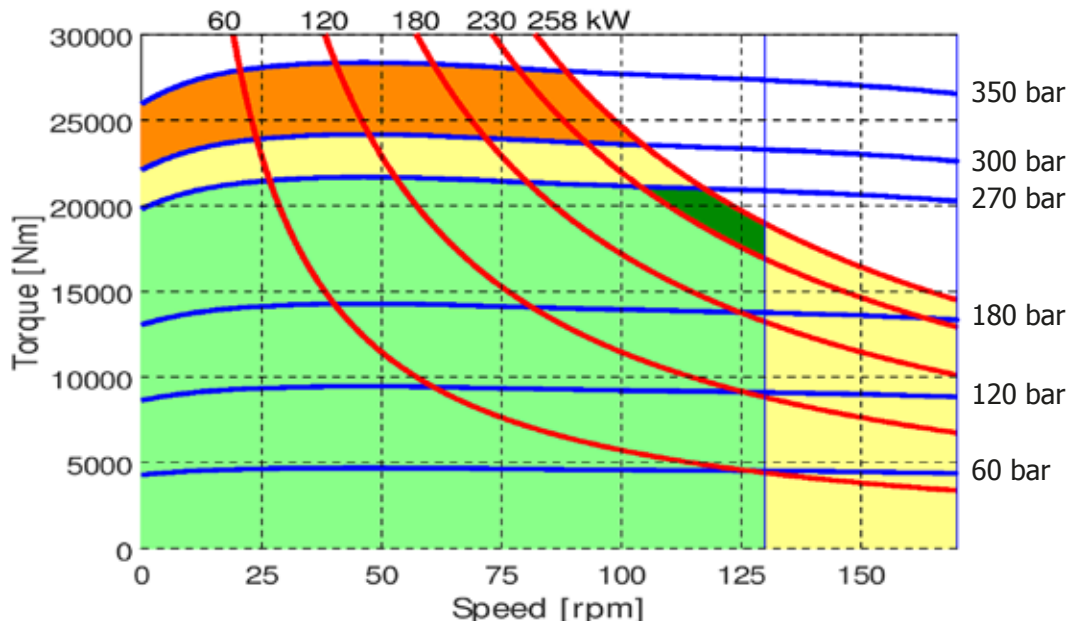

- Continuous operation
- Continuous operation with flushing or intermittent operation (see below for intermittent operation)
- Intermittent operation: permitted for a 15% of duty cycle, for 3 minutes maximum period
- Peak operation: permitted for very short periods (3-5 seconds every 10-15 minutes)

The above diagrams are referring to the hydraulic motor working with a fluid in ideal conditions (viscosity at 40 cSt). In case the working temperature increases and viscosity reach values under the recommended values (see hydraulic fluid recommendations) flushing must be performed or ISO oil grade must be changed. The working temperature must not overcome 70 °C.

R8D 5400 H7

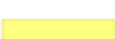

-  Continuous operation
-  Continuous operation with flushing or intermittent operation (see below for intermittent operation)
-  Intermittent operation: permitted for a 15% of duty cycle, for 3 minutes maximum period
-  Peak operation: permitted for very short periods (3-5 seconds every 10-15 minutes)

The above diagrams are referring to the hydraulic motor working with a fluid in ideal conditions (viscosity at 40 cSt). In case the working temperature increases and viscosity reach values under the recommended values (see hydraulic fluid recommendations) flushing must be performed or ISO oil grade must be changed. The working temperature must not overcome 70 °C.

R8D H7 - PERFORMANCE CURVES

CREEP SPEED - VOLUMETRIC EFFICIENCY

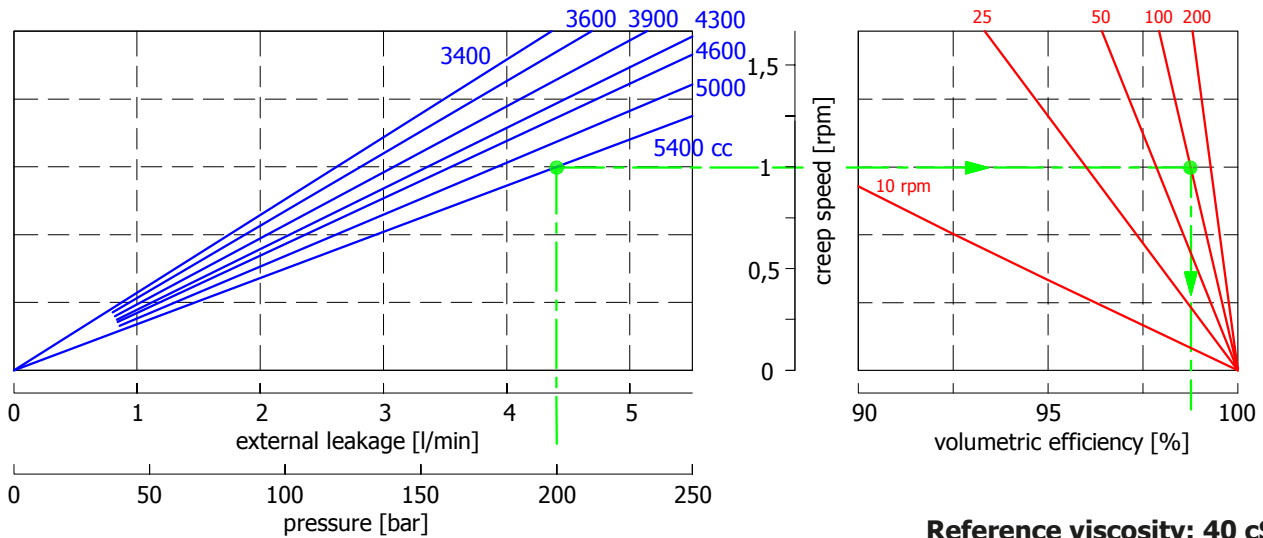

Reference viscosity: 40 cSt

Example:

We suppose (5400 cc): $p=200$ [bar], we obtain: external leakage 4,3 [l/min], shaft creep speed 1 [rpm].
 If we suppose (5400 cc): $p=200$ [bar] and $n=100$ [rpm] we obtain a volumetric efficiency of 98,5%;

BEARING LIFE

Reference displacement 4600 cc

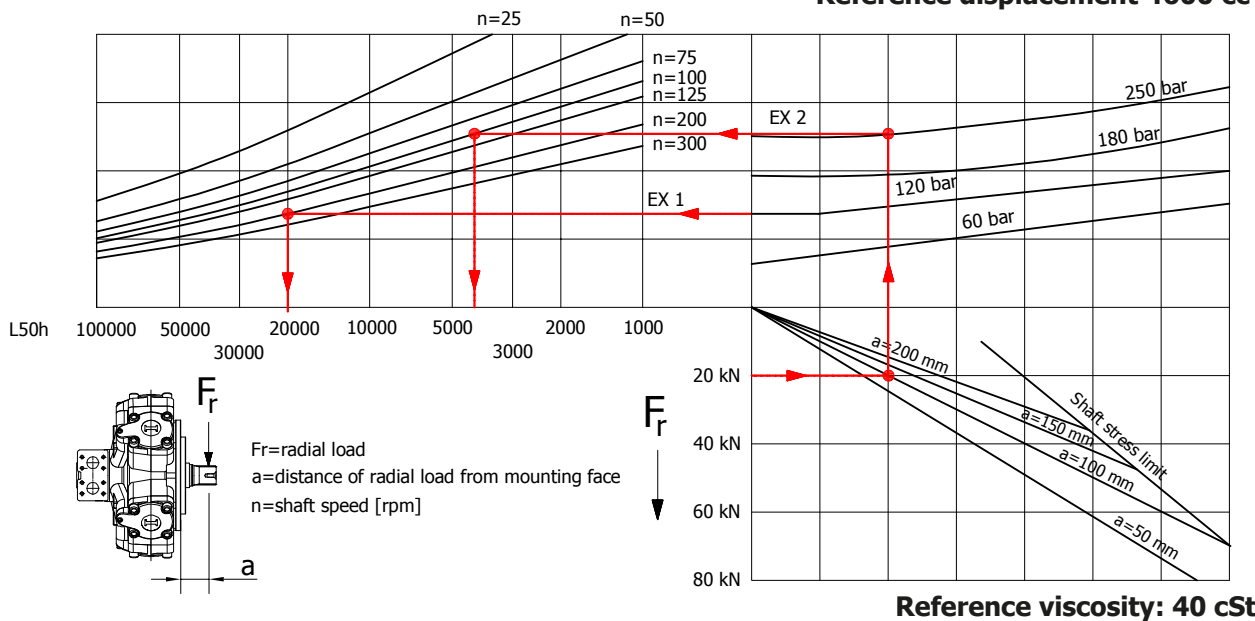

Reference viscosity: 40 cSt

Example:

We suppose (EX1): $p=120$ [bar], $n=200$ [rpm]; we obtain an average lifetime of 20000 [h].
 If we suppose (EX2): $F_r=20$ [kN], $a=100$ [mm], $n=100$ [rpm] and $p=250$ [bar] we obtain an average lifetime of 4000 [h].

R8D H7 - ORDERING CODE

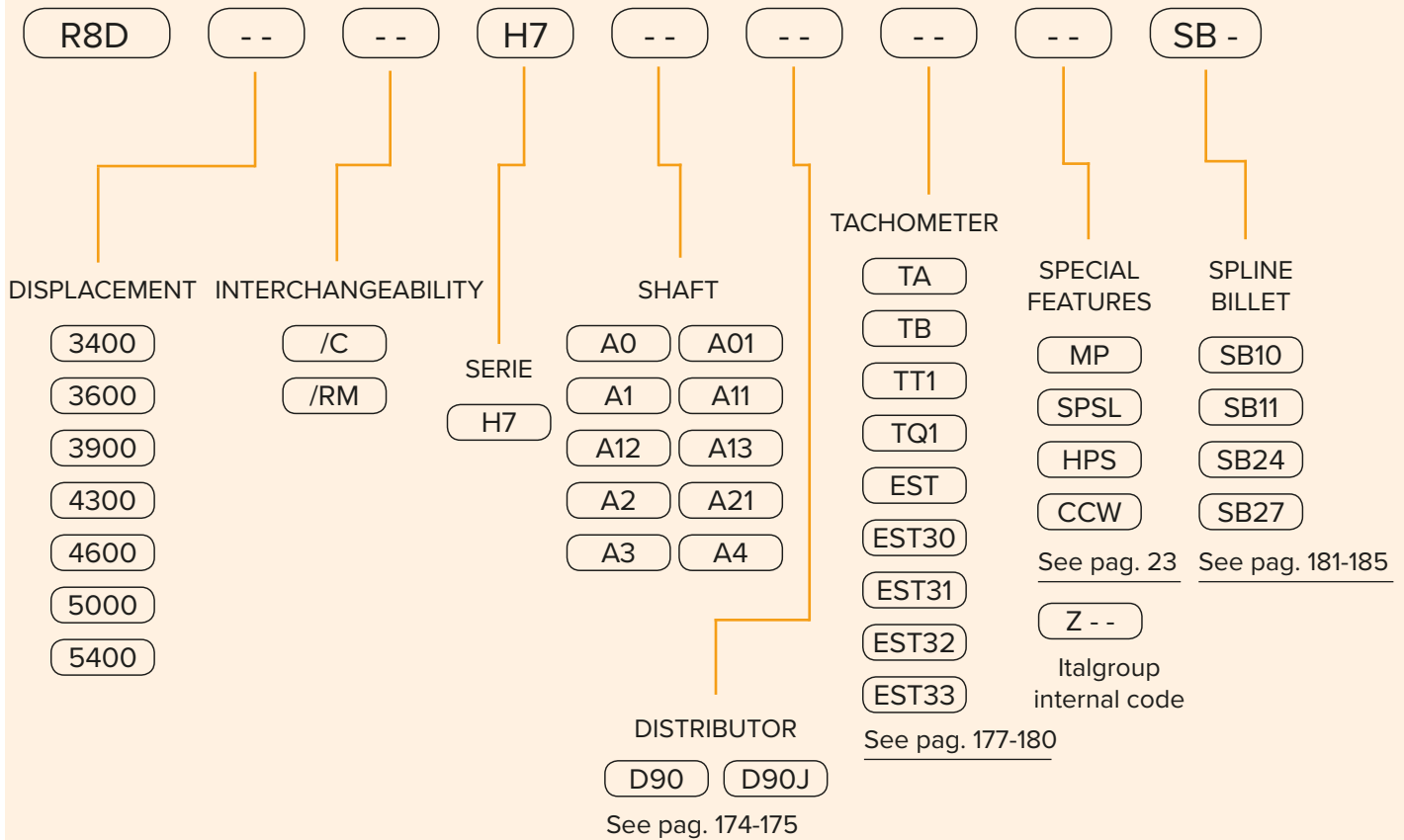

EXAMPLES:

R8D 4600 H7 A1 D90 CCW
 R8D 5000 H7 A0 D90 SB10
 R8D 5400/C H7 A0 D90

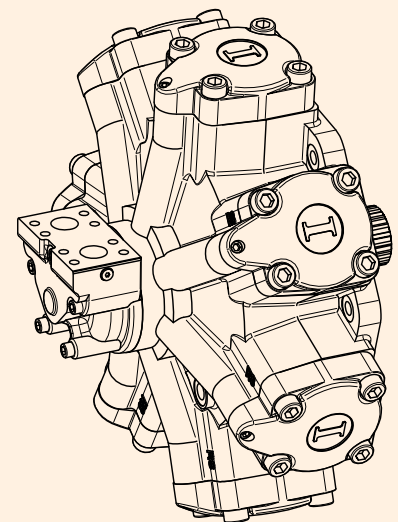

R8D H8

R8D H8	Pag. 152 - 154
R8D H8/C	Pag. 156 - 157
R8D H8 - PERFORMANCE CURVES	Pag. 158 - 161
R8D H8 - ORDERING CODE	Pag. 162

R8D H8

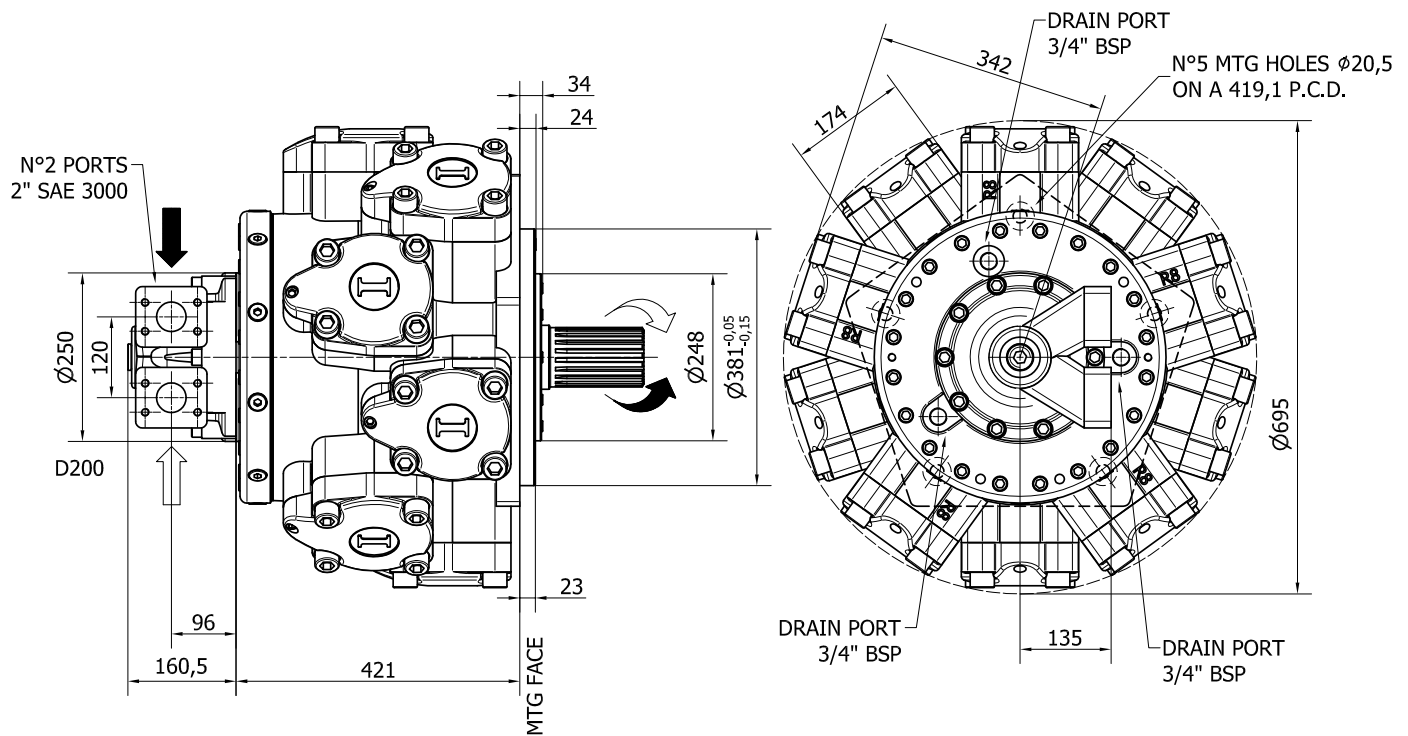

TECHNICAL DATA

		3000	6000	6500	6800	7600	8000
DISPLACEMENT	[cc]	3020	5966	6581	6962	7620	8062
SPECIFIC TORQUE	[Nm/bar]	48.1	95	104.7	110.8	121.3	128.3
MAX. CONT. PRESSURE	[bar]	270	250	250	250	250	240
HYDROSTATIC TEST PRESSURE	[bar]	420	420	420	420	420	420
MAX. CONT. SPEED	[rpm]	240	120	120	120	90	80
PEAK SPEED (**)	[rpm]	300	140	140	140	100	90
MAX. CONT. POWER (***)	[kW]	215	215	215	215	215	215
MAX. POWER	[kW]	236	236	236	236	236	236
MAX. CASE PRESSURE	[bar]	6	6	6	6	6	6
DRY WEIGHT	[kg]	590	590	590	590	590	590
TEMPERATURE RANGE (*)	[°C]	-30÷70	-30÷70	-30÷70	-30÷70	-30÷70	-30÷70

- (*) Please refer to the hydraulic fluid recommendations (pag. 10-11).

- (**) Do not exceed maximum power (see pag. 13).

- (***) For motor operation with a continuous duty cycle at maximum continuous power the flushing is usually required. For more information please contact our technical department.

SHAFTS

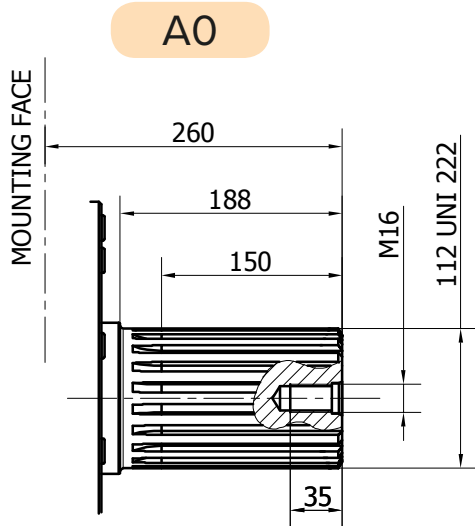

Available spline billet: SB12

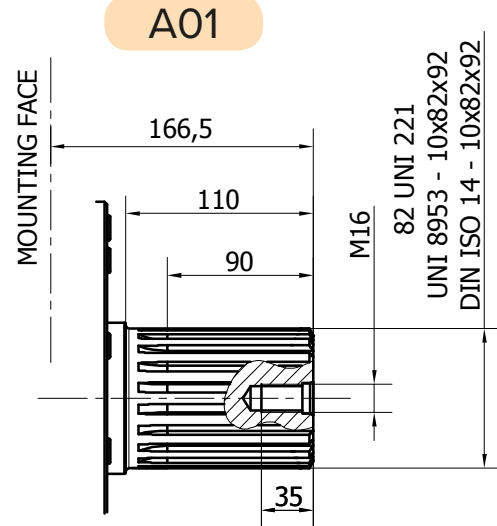

Available spline billet: SB10

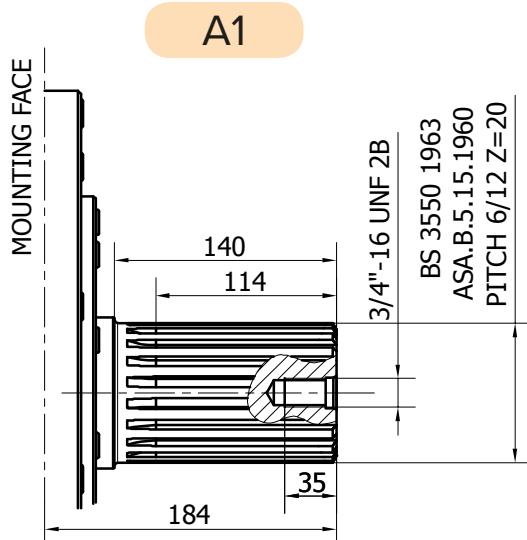

Available spline billet: SB24

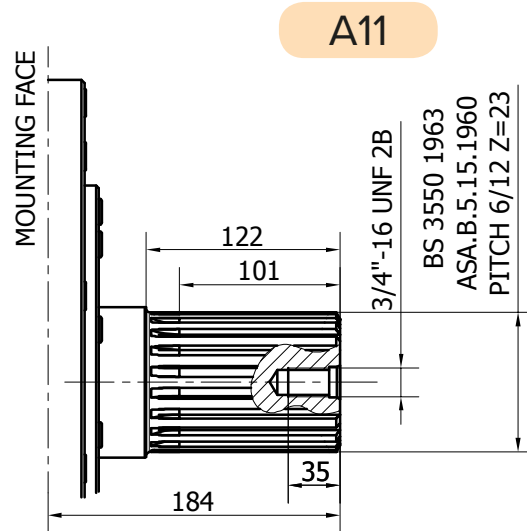

R8D H8

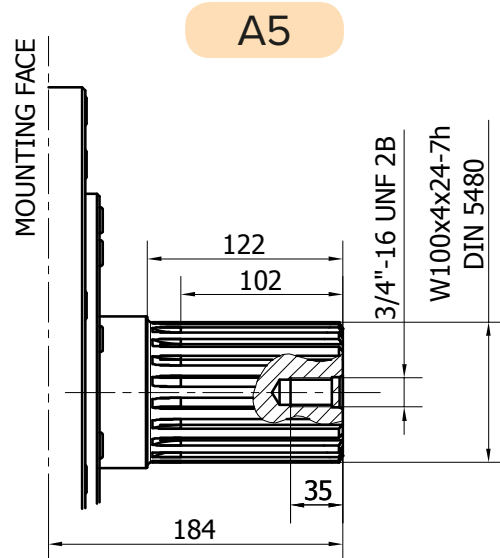
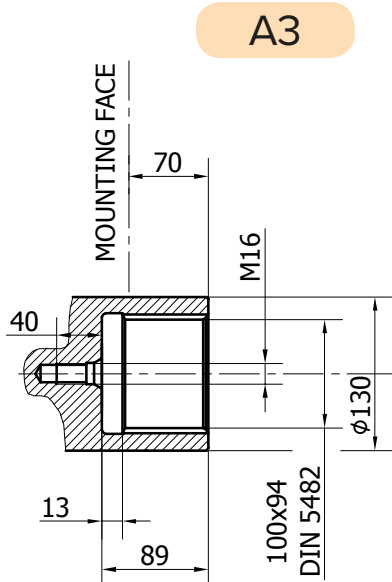
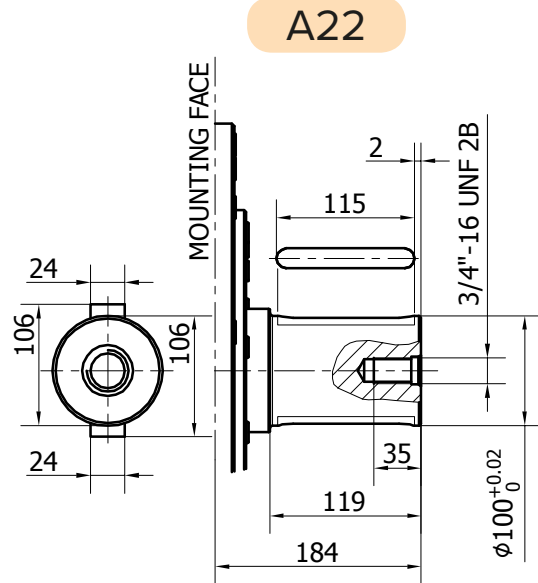
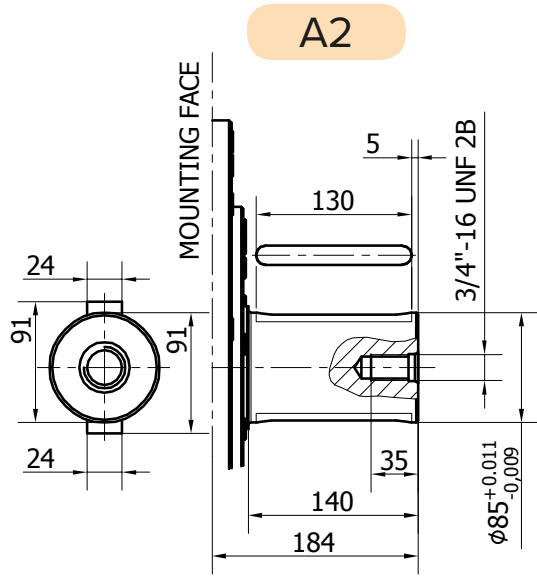

SHAFTS

R8D H8/C

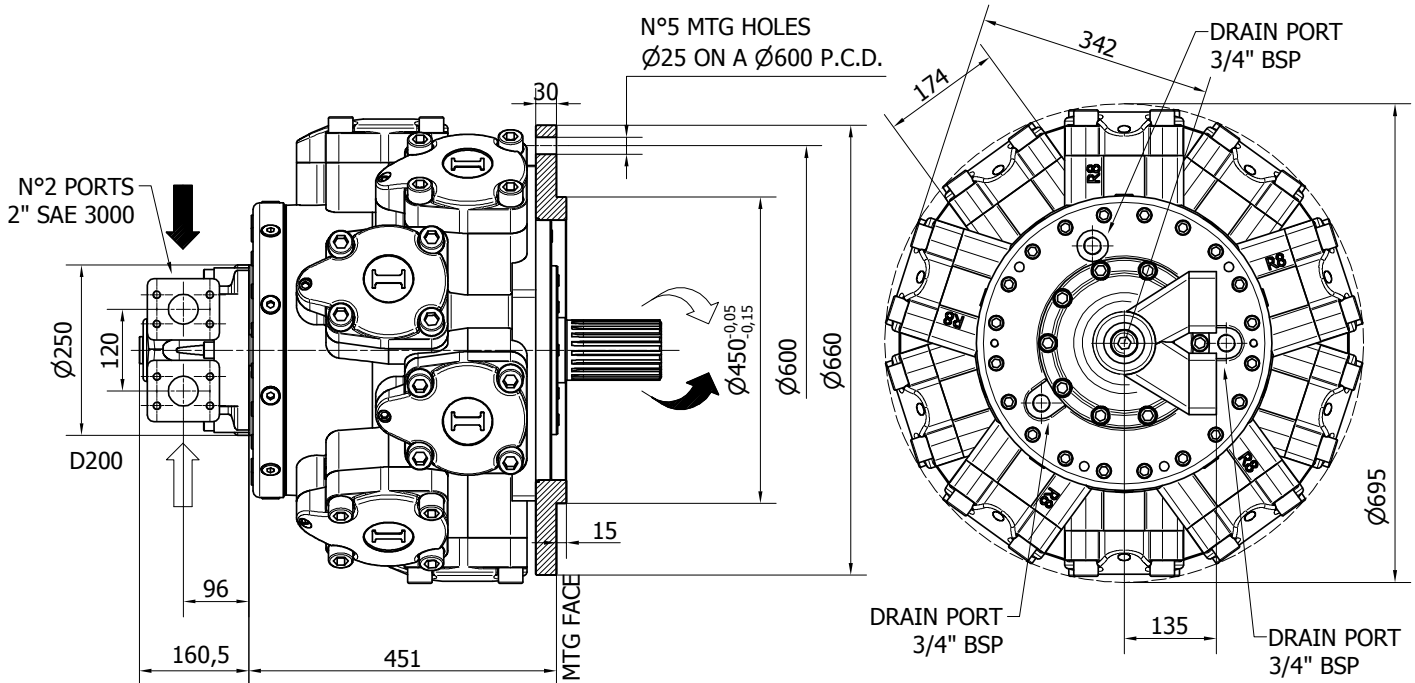

TECHNICAL DATA

		3000	6000	6500	6800	7600	8000
DISPLACEMENT	[cc]	3020	5966	6581	6962	7620	8062
SPECIFIC TORQUE	[Nm/bar]	48.1	95	104.7	110.8	121.3	128.3
MAX. CONT. PRESSURE	[bar]	270	250	250	250	250	240
HYDROSTATIC TEST PRESSURE	[bar]	420	420	420	420	420	420
MAX. CONT. SPEED	[rpm]	240	120	120	120	90	80
PEAK SPEED (**)	[rpm]	300	140	140	140	100	90
MAX. CONT. POWER (***)	[kW]	215	215	215	215	215	215
MAX. POWER	[kW]	236	236	236	236	236	236
MAX. CASE PRESSURE	[bar]	6	6	6	6	6	6
DRY WEIGHT	[kg]	590	590	590	590	590	590
TEMPERATURE RANGE (*)	[°C]	-30÷70	-30÷70	-30÷70	-30÷70	-30÷70	-30÷70

- (*) Please refer to the hydraulic fluid recommendations (pag. 10-11).

- (**) Do not exceed maximum power (see pag. 13).

- (***) For motor operation with a continuous duty cycle at maximum continuous power the flushing is usually required. For more information please contact our technical department.

SHAFTS

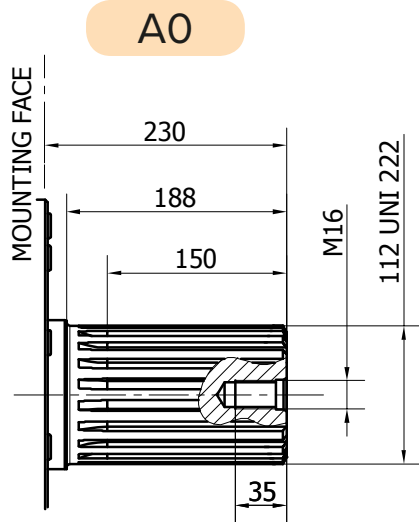

Available spline billet: SB12

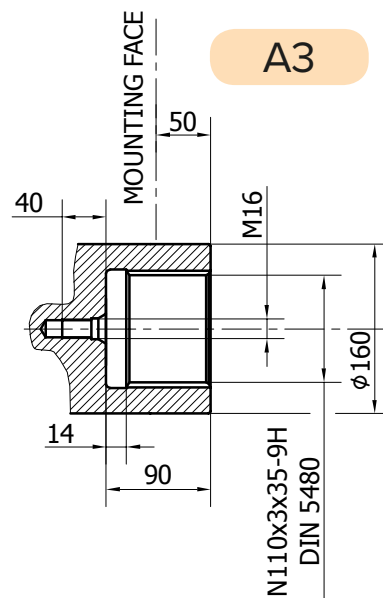
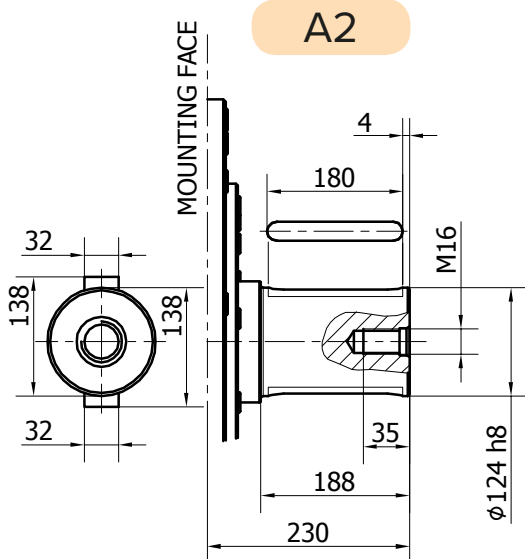
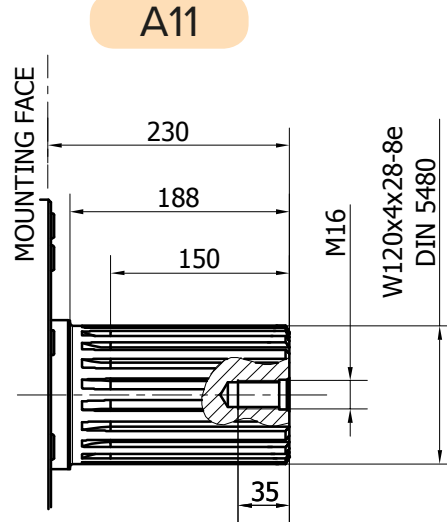

R8D H8 - PERFORMANCE CURVES

R8D 3000 H8

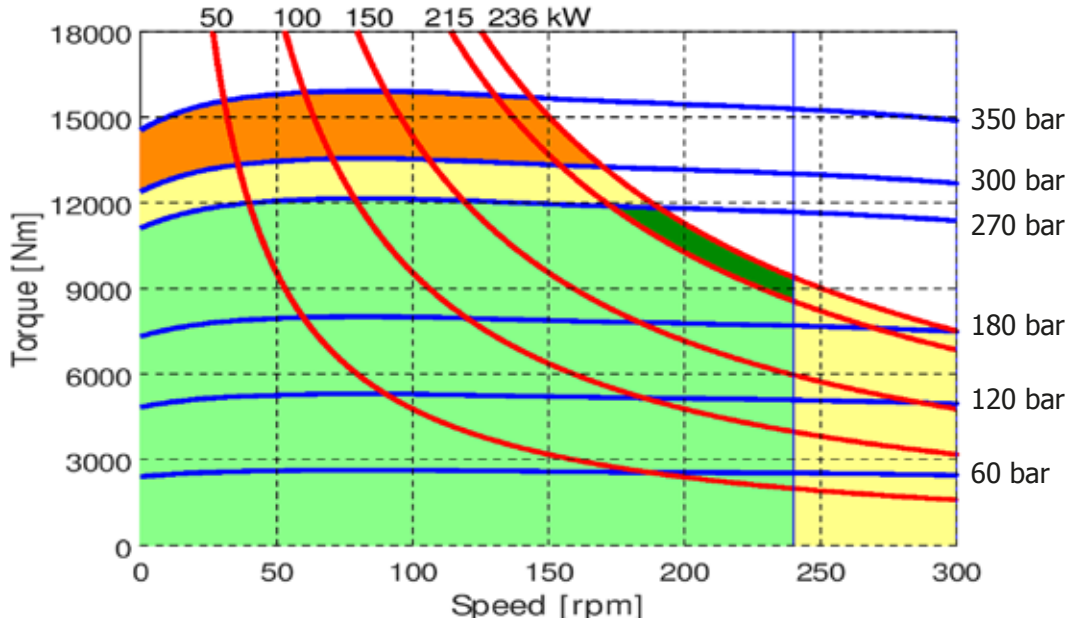

R8D 6000 H8

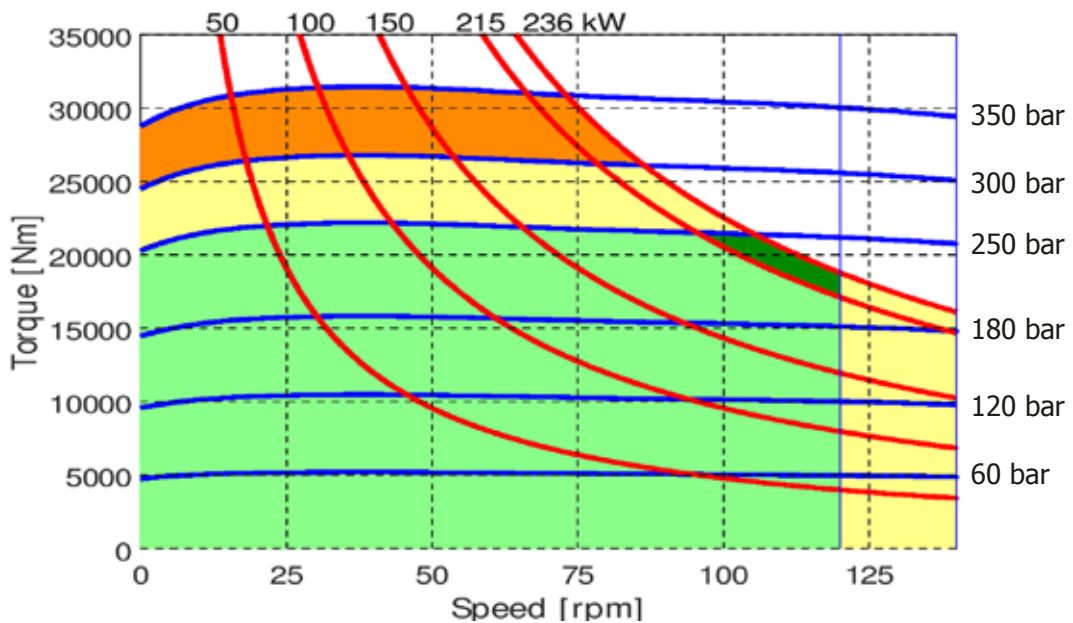

- Continuous operation
- Continuous operation with flushing or intermittent operation (see below for intermittent operation)
- Intermittent operation: permitted for a 15% of duty cycle, for 3 minutes maximum period
- Peak operation: permitted for very short periods (3-5 seconds every 10-15 minutes)

The above diagrams are referring to the hydraulic motor working with a fluid in ideal conditions (viscosity at 40 cSt). In case the working temperature increases and viscosity reach values under the recommended values (see hydraulic fluid recommendations) flushing must be performed or ISO oil grade must be changed. The working temperature must not overcome 70 °C.

R8D 6500 H8

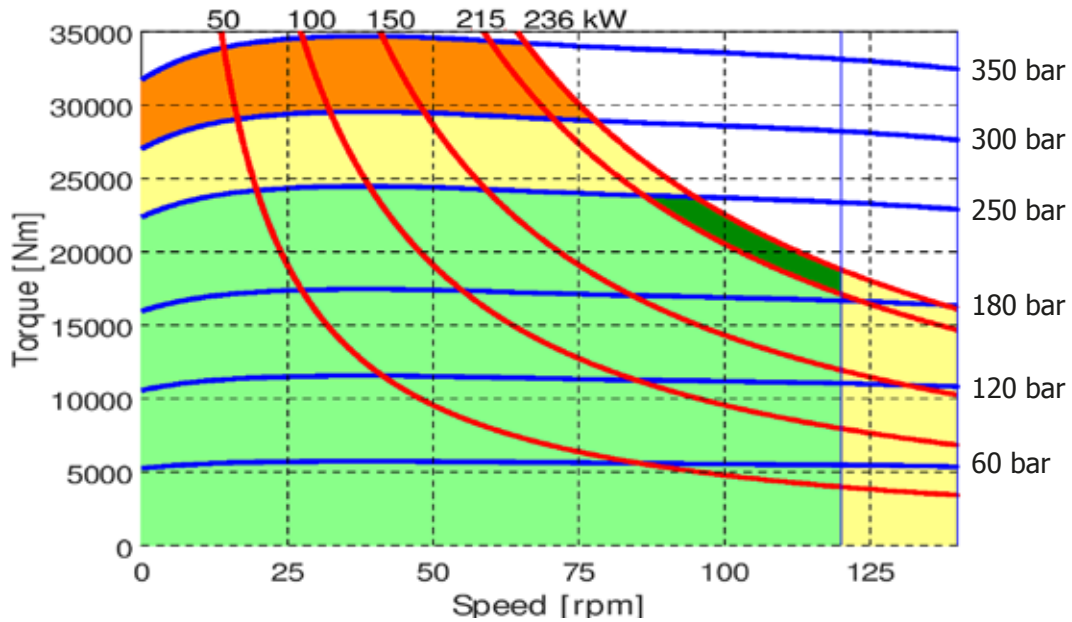

R8D 6800 H8

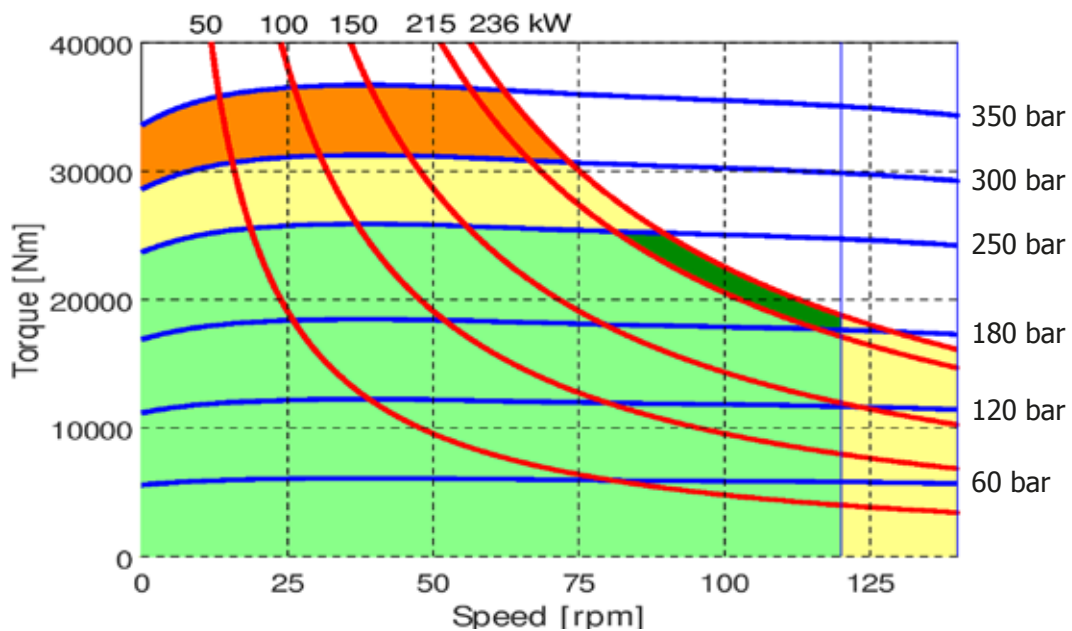

- Continuous operation
- Continuous operation with flushing or intermittent operation (see below for intermittent operation)
- Intermittent operation: permitted for a 15% of duty cycle, for 3 minutes maximum period
- Peak operation: permitted for very short periods (3-5 seconds every 10-15 minutes)

The above diagrams are referring to the hydraulic motor working with a fluid in ideal conditions (viscosity at 40 cSt). In case the working temperature increases and viscosity reach values under the recommended values (see hydraulic fluid recommendations) flushing must be performed or ISO oil grade must be changed. The working temperature must not overcome 70 °C.

R8D H8 - PERFORMANCE CURVES

R8D 7600 H8

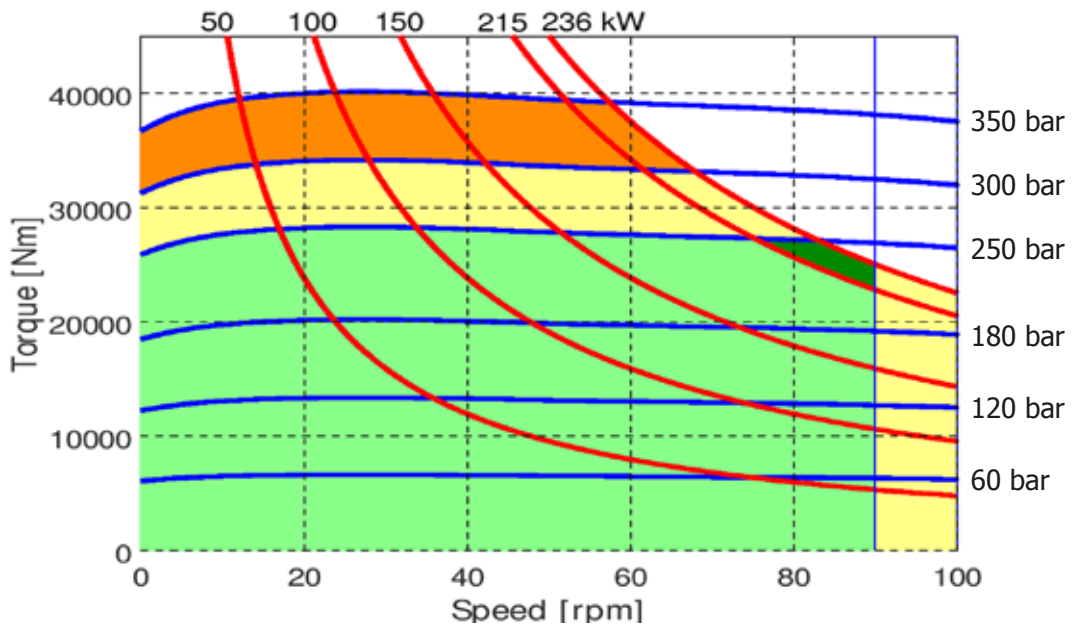

R8D 8000 H8

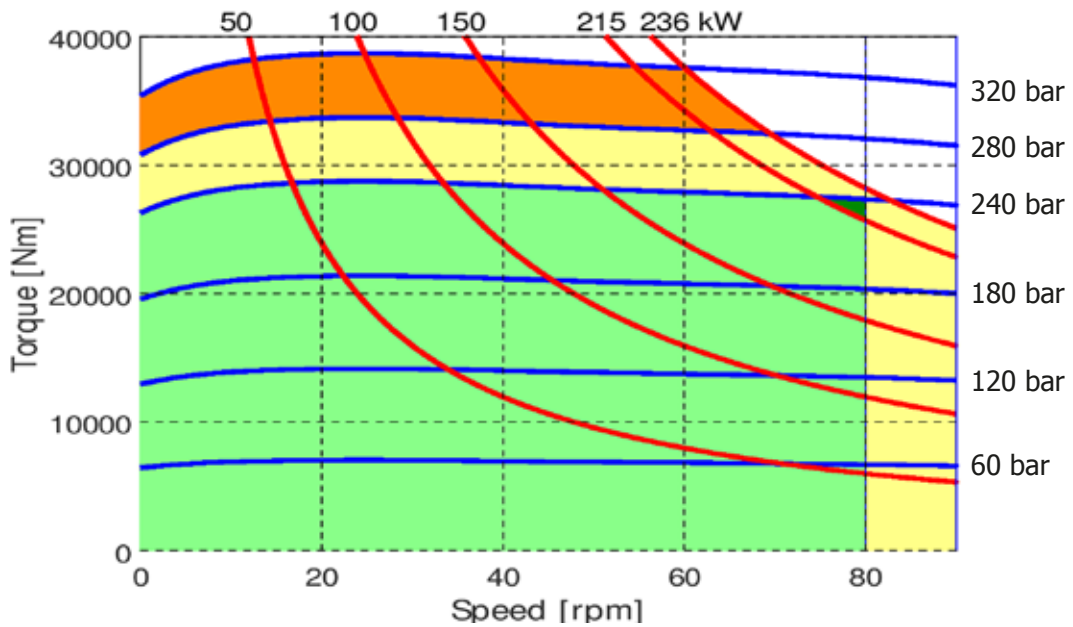

- Continuous operation
- Continuous operation with flushing or intermittent operation (see below for intermittent operation)
- Intermittent operation: permitted for a 15% of duty cycle, for 3 minutes maximum period
- Peak operation: permitted for very short periods (3-5 seconds every 10-15 minutes)

The above diagrams are referring to the hydraulic motor working with a fluid in ideal conditions (viscosity at 40 cSt). In case the working temperature increases and viscosity reach values under the recommended values (see hydraulic fluid recommendations) flushing must be performed or ISO oil grade must be changed. The working temperature must not overcome 70 °C.

CREEP SPEED - VOLUMETRIC EFFICIENCY

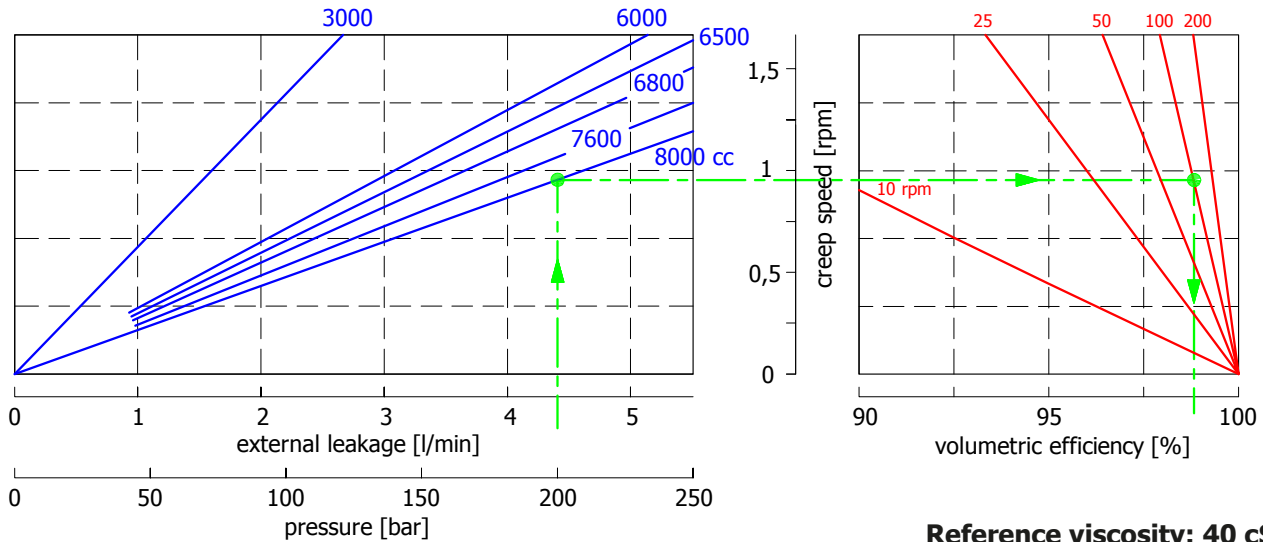

Reference viscosity: 40 cSt

Example:

We suppose (8000 cc): $p=200$ [bar], we obtain: external leakage 4,3 [l/min], shaft creep speed 0,95 [rpm].
 If we suppose (8000 cc): $p=200$ [bar] and $n=100$ [rpm] we obtain a volumetric efficiency of 98,5%;

BEARING LIFE

Reference displacement 6800 cc

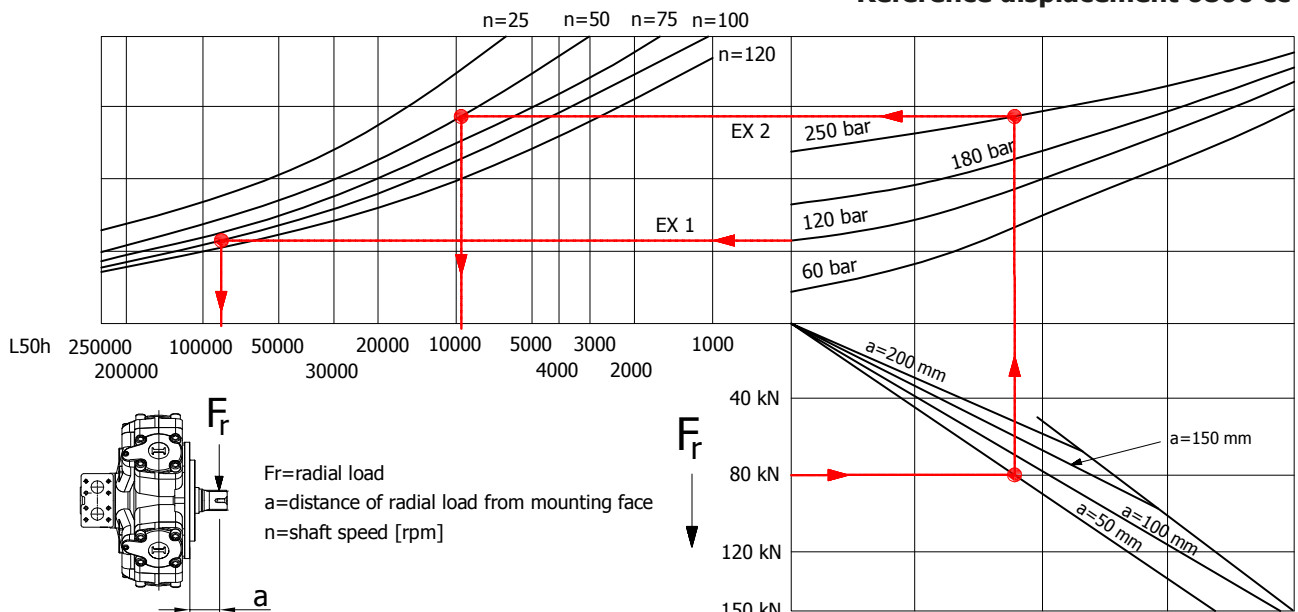

Reference viscosity: 40 cSt

Example:

We suppose (EX1): $p=120$ [bar], $n=100$ [rpm]; we obtain an average lifetime of 85000 [h].
 If we suppose (EX2): $F_r=80$ [kN], $a=50$ [mm], $n=50$ [rpm] and $p=250$ [bar] we obtain an average lifetime of 9000 [h].

R8D H8 - ORDERING CODE

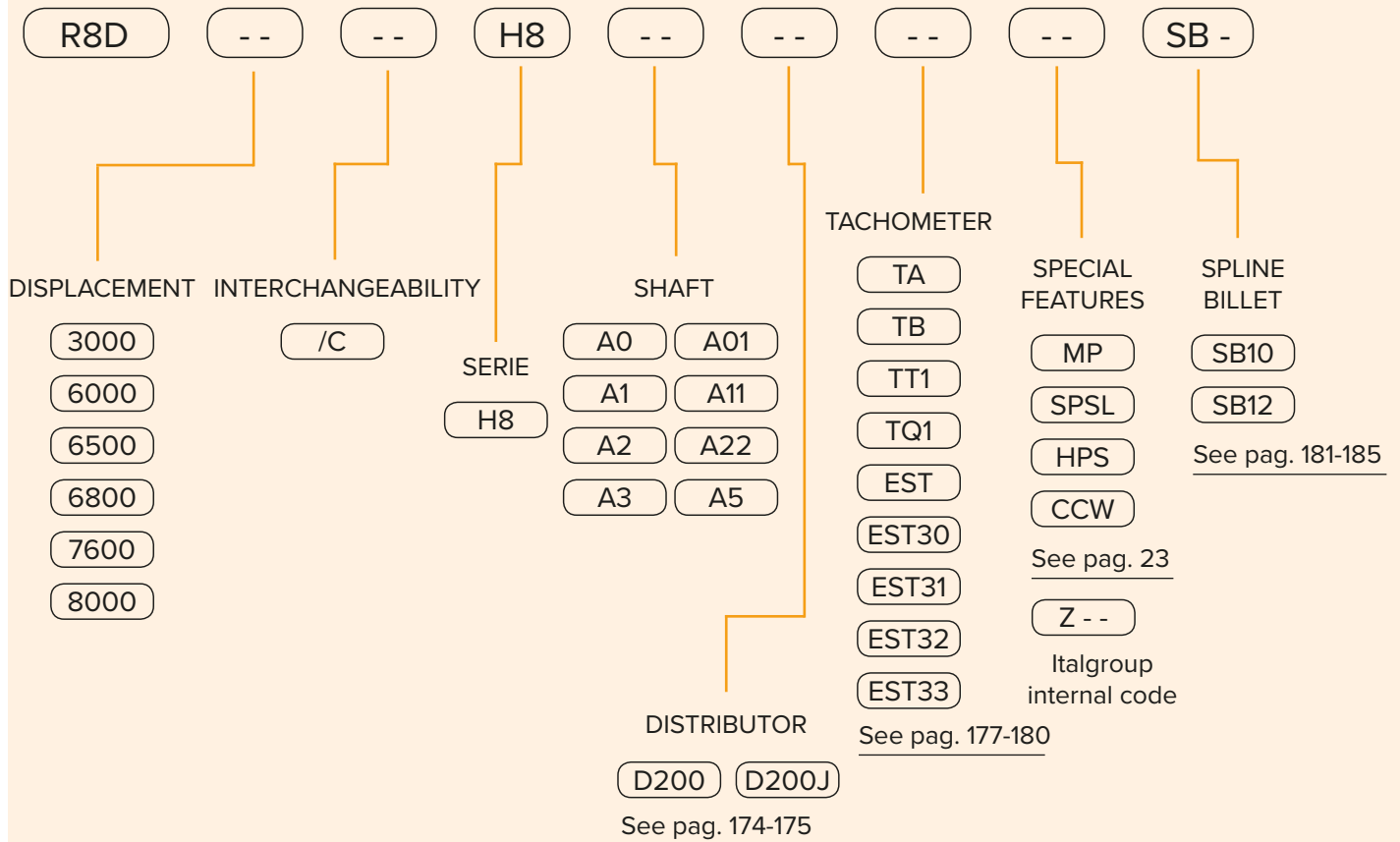

EXAMPLES:

R8D 3000 H8 A1 D200
R8D 6500/C H8 A0 D200 CCW
R8D 6800 H8 A4 D200 EST30

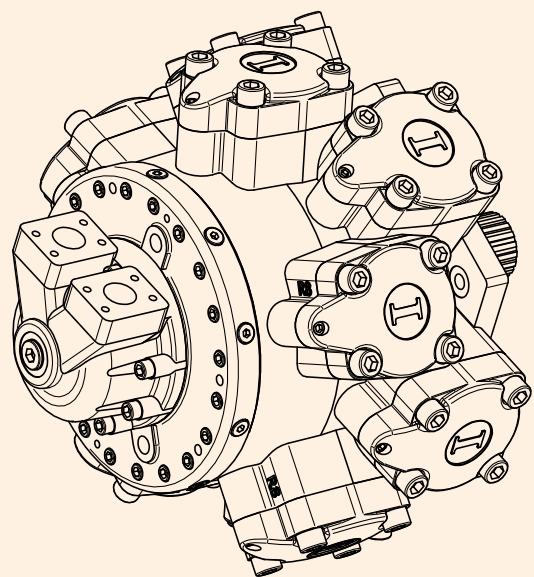

R8D H9

R8D H9	Pag. 164 - 165
R8D H9/C	Pag. 166 - 167
R8D H9 - PERFORMANCE CURVES	Pag. 168 - 172
R8D H9 - ORDERING CODE	Pag. 173

R8D H9

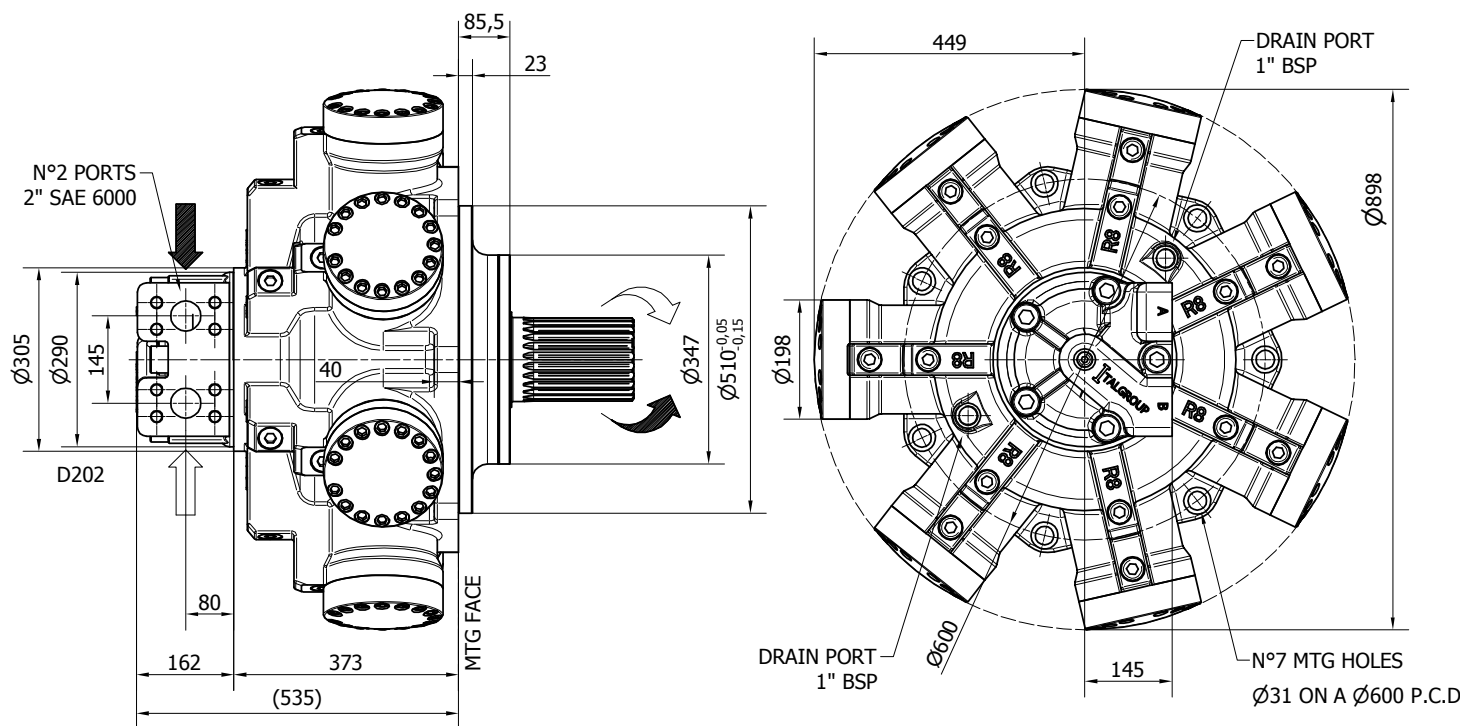

TECHNICAL DATA

		7000	8000	9000	10000	11000	12000	13000
DISPLACEMENT	[cc]	7050	8332	8757	10214	11016	12073	13020
SPECIFIC TORQUE	[Nm/bar]	112	132.6	139.4	162.6	175.3	192.2	207.3
MAX. CONT. PRESSURE	[bar]	270	270	260	250	250	250	250
HYDROSTATIC TEST PRESSURE	[bar]	420	420	420	420	420	420	420
MAX. CONT. SPEED	[rpm]	160	135	130	110	105	95	90
PEAK SPEED (**)	[rpm]	190	160	155	135	120	110	105
MAX. CONT. POWER (***)	[kW]	330	330	330	330	330	330	330
MAX. POWER	[kW]	370	370	370	370	370	370	370
MAX. CASE PRESSURE	[bar]	6	6	6	6	6	6	6
DRY WEIGHT	[kg]	750	750	750	750	750	750	750
TEMPERATURE RANGE (*)	[°C]	-30÷70	-30÷70	-30÷70	-30÷70	-30÷70	-30÷70	-30÷70

- (*) Please refer to the hydraulic fluid recommendations (pag. 10-11).

- (**) Do not exceed maximum power (see pag. 13).

- (***) For motor operation with a continuous duty cycle at maximum continuous power the flushing is usually required. For more information please contact our technical department.

SHAFTS

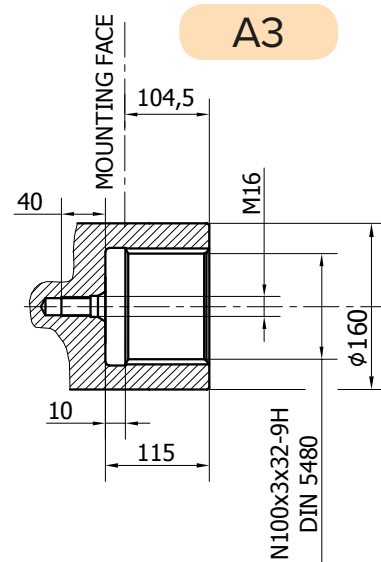
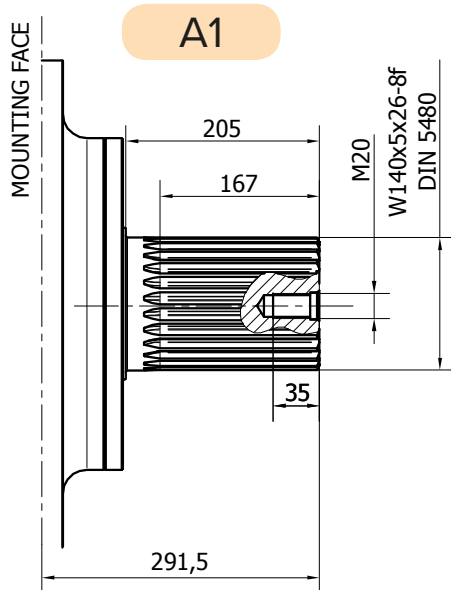

Available only for
7000 - 8000 - 9000 - 10000 cc

R8D H9/C

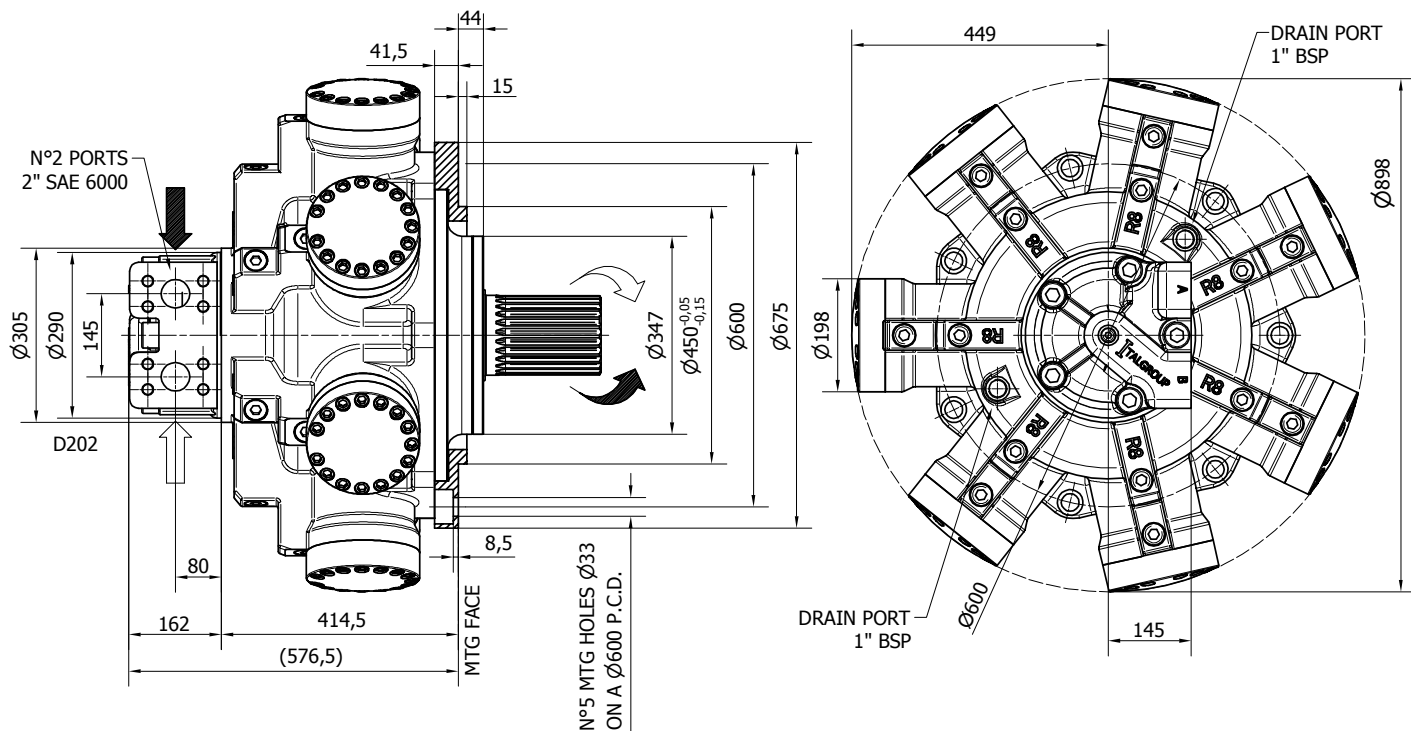

TECHNICAL DATA

		7000	8000	9000	10000	11000	12000	13000
DISPLACEMENT	[cc]	7050	8332	8757	10214	11016	12073	13020
SPECIFIC TORQUE	[Nm/bar]	112	132.6	139.4	162.6	175.3	192.2	207.3
MAX. CONT. PRESSURE	[bar]	270	270	260	250	250	250	250
HYDROSTATIC TEST PRESSURE	[bar]	420	420	420	420	420	420	420
MAX. CONT. SPEED	[rpm]	160	135	130	110	105	95	90
PEAK SPEED (**)	[rpm]	190	160	155	135	120	110	105
MAX. CONT. POWER (***)	[kW]	330	330	330	330	330	330	330
MAX. POWER	[kW]	370	370	370	370	370	370	370
MAX. CASE PRESSURE	[bar]	6	6	6	6	6	6	6
DRY WEIGHT	[kg]	750	750	750	750	750	750	750
TEMPERATURE RANGE (*)	[°C]	-30÷70	-30÷70	-30÷70	-30÷70	-30÷70	-30÷70	-30÷70

- (*) Please refer to the hydraulic fluid recommendations (pag. 10-11).

- (**) Do not exceed maximum power (see pag. 13).

- (***) For motor operation with a continuous duty cycle at maximum continuous power the flushing is usually required. For more information please contact our technical department.

SHAFTS

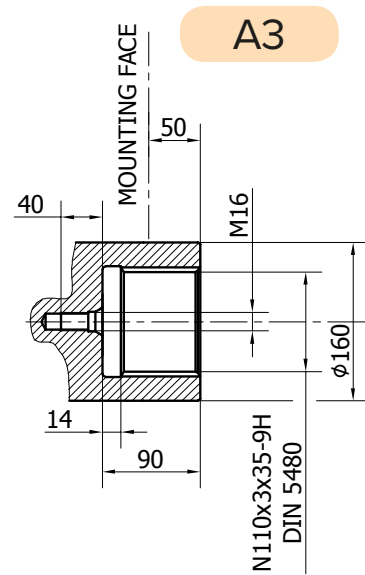
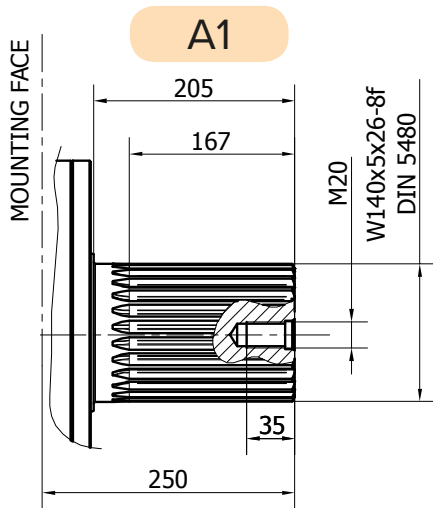

Available only for
8000 cc

R8D H9 - PERFORMANCE CURVES

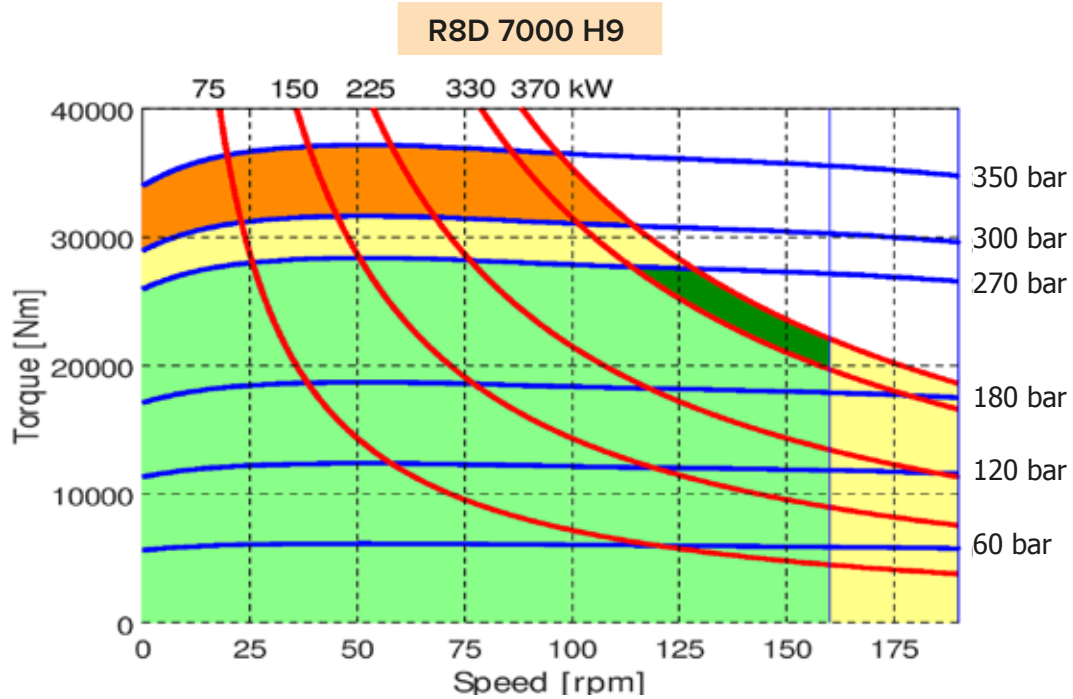

- Continuous operation
- Continuous operation with flushing or intermittent operation (see below for intermittent operation)
- Intermittent operation: permitted for a 15% of duty cycle, for 3 minutes maximum period
- Peak operation: permitted for very short periods (3-5 seconds every 10-15 minutes)

The above diagrams are referring to the hydraulic motor working with a fluid in ideal conditions (viscosity at 40 cSt). In case the working temperature increases and viscosity reach values under the recommended values (see hydraulic fluid recommendations) flushing must be performed or ISO oil grade must be changed. The working temperature must not overcome 70 °C.

R8D 9000 H9

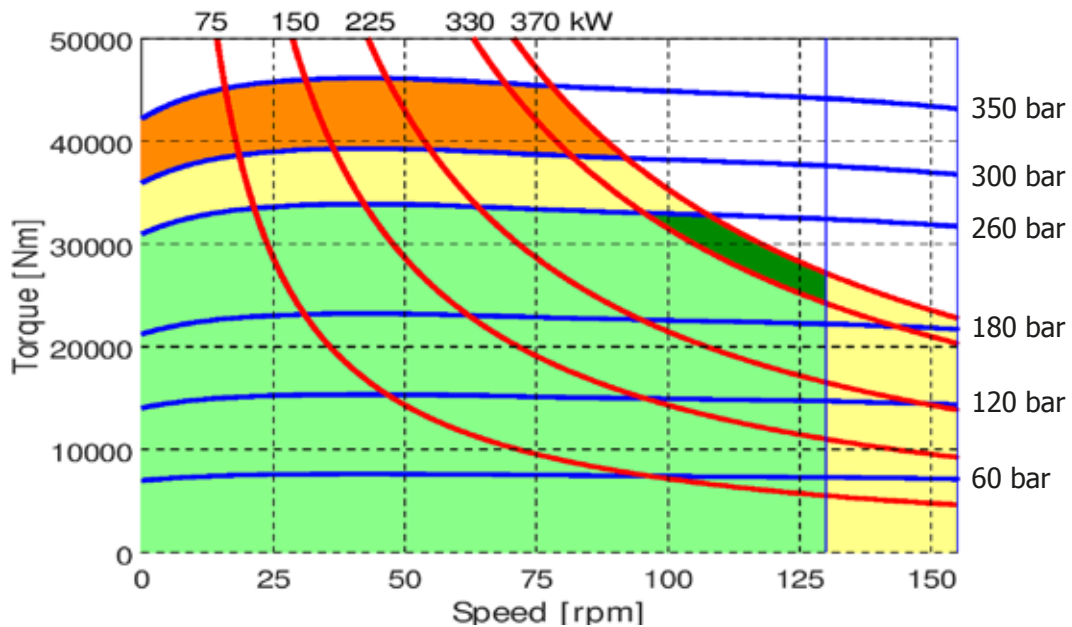

R8D 10000 H9

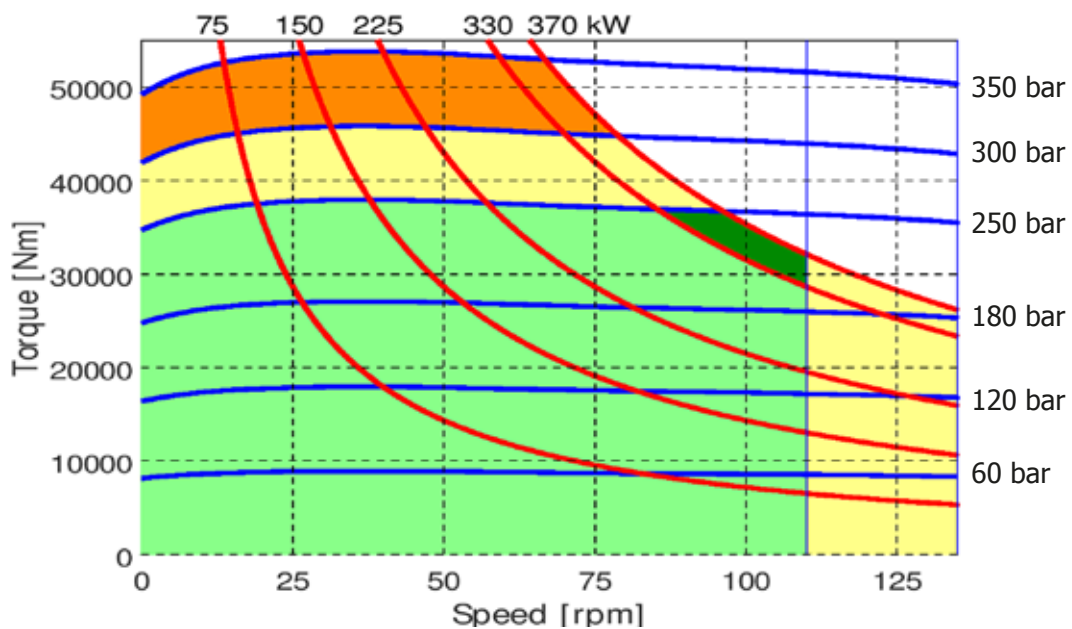

- Continuous operation
- Continuous operation with flushing or intermittent operation (see below for intermittent operation)
- Intermittent operation: permitted for a 15% of duty cycle, for 3 minutes maximum period
- Peak operation: permitted for very short periods (3-5 seconds every 10-15 minutes)

The above diagrams are referring to the hydraulic motor working with a fluid in ideal conditions (viscosity at 40 cSt). In case the working temperature increases and viscosity reach values under the recommended values (see hydraulic fluid recommendations) flushing must be performed or ISO oil grade must be changed. The working temperature must not overcome 70 °C.

R8D H9 - PERFORMANCE CURVES

R8D 11000 H9

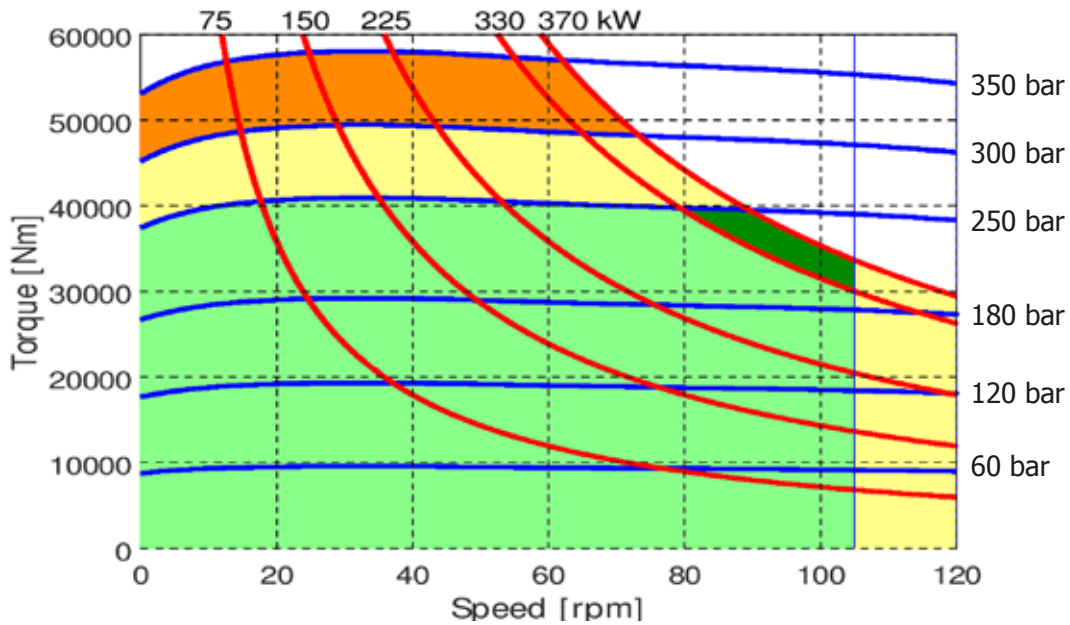

R8D 12000 H9

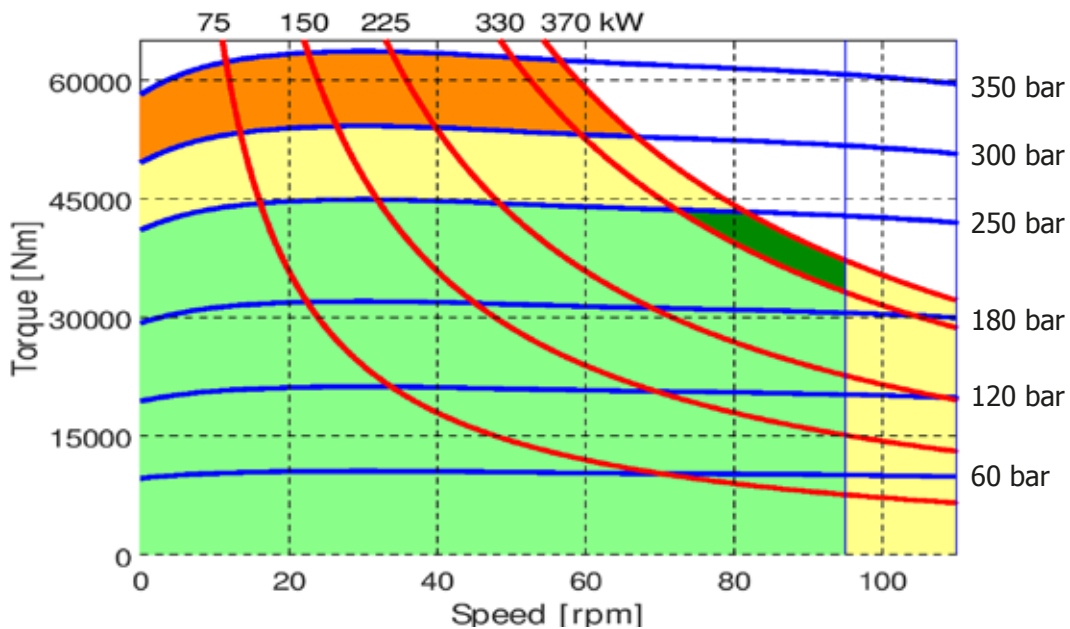

- Continuous operation
- Continuous operation with flushing or intermittent operation (see below for intermittent operation)
- Intermittent operation: permitted for a 15% of duty cycle, for 3 minutes maximum period
- Peak operation: permitted for very short periods (3-5 seconds every 10-15 minutes)

The above diagrams are referring to the hydraulic motor working with a fluid in ideal conditions (viscosity at 40 cSt). In case the working temperature increases and viscosity reach values under the recommended values (see hydraulic fluid recommendations) flushing must be performed or ISO oil grade must be changed. The working temperature must not overcome 70 °C.

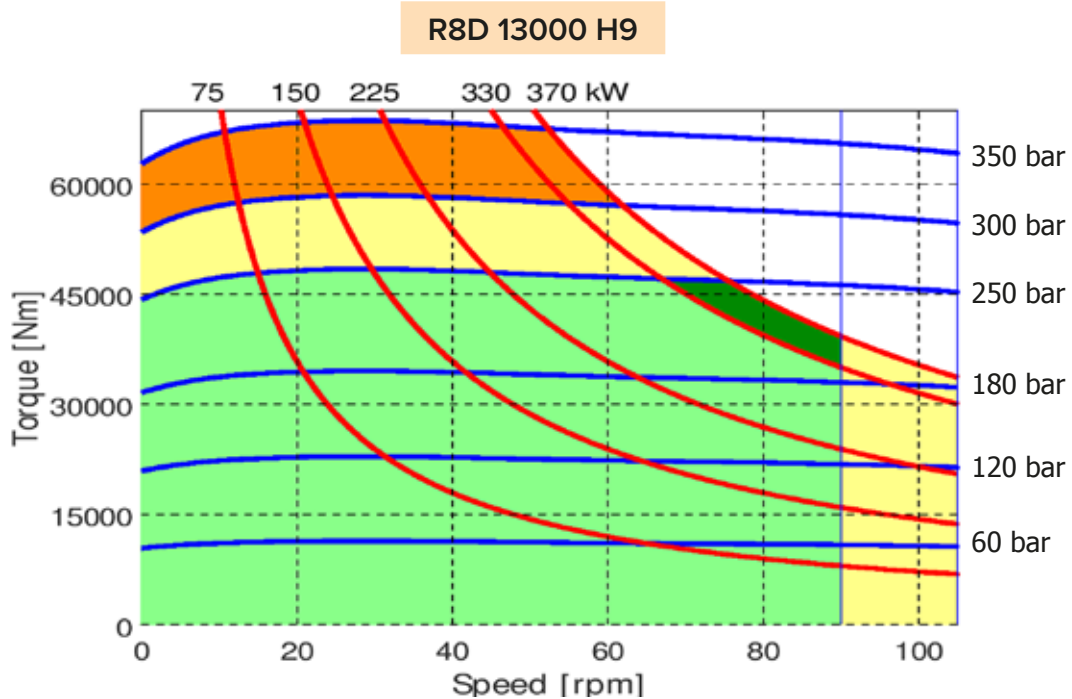

- Continuous operation
- Continuous operation with flushing or intermittent operation (see below for intermittent operation)
- Intermittent operation: permitted for a 15% of duty cycle, for 3 minutes maximum period
- Peak operation: permitted for very short periods (3-5 seconds every 10-15 minutes)

The above diagrams are referring to the hydraulic motor working with a fluid in ideal conditions (viscosity at 40 cSt). In case the working temperature increases and viscosity reach values under the recommended values (see hydraulic fluid recommendations) flushing must be performed or ISO oil grade must be changed. The working temperature must not overcome 70 °C.

R8D H9 - PERFORMANCE CURVES

CREEP SPEED - VOLUMETRIC EFFICIENCY

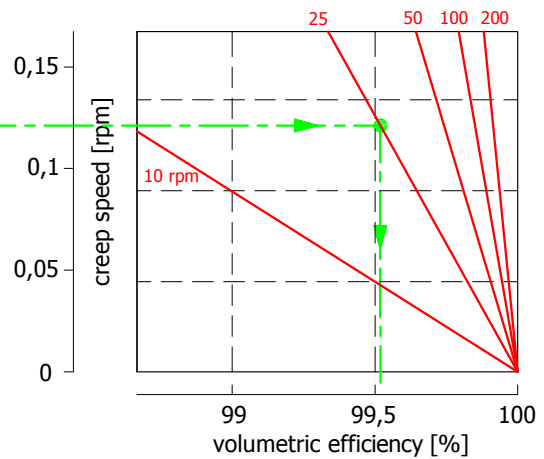
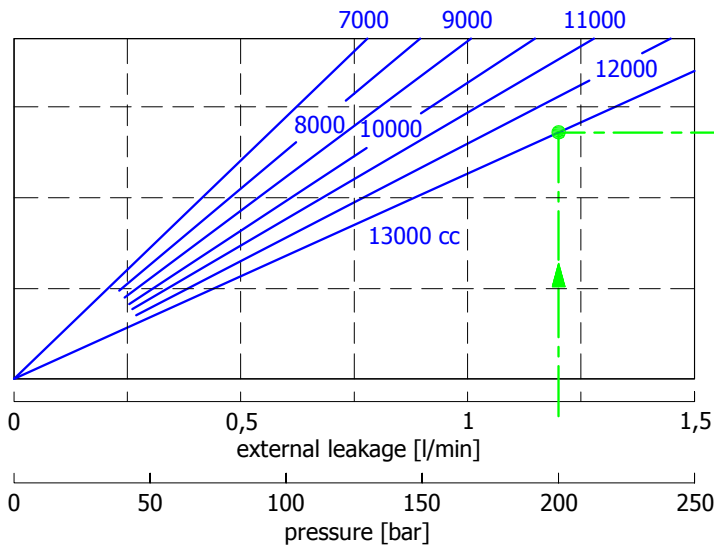

Reference viscosity: 40 cSt

Example:

We suppose (13000 cc): $p=200$ [bar], we obtain: external leakage 1,2 [l/min], shaft creep speed 0,12 [rpm].
If we suppose (13000 cc): $p=200$ [bar] and $n=25$ [rpm] we obtain a volumetric efficiency of 99,5%;

BEARING LIFE

Reference displacement 10000 cc

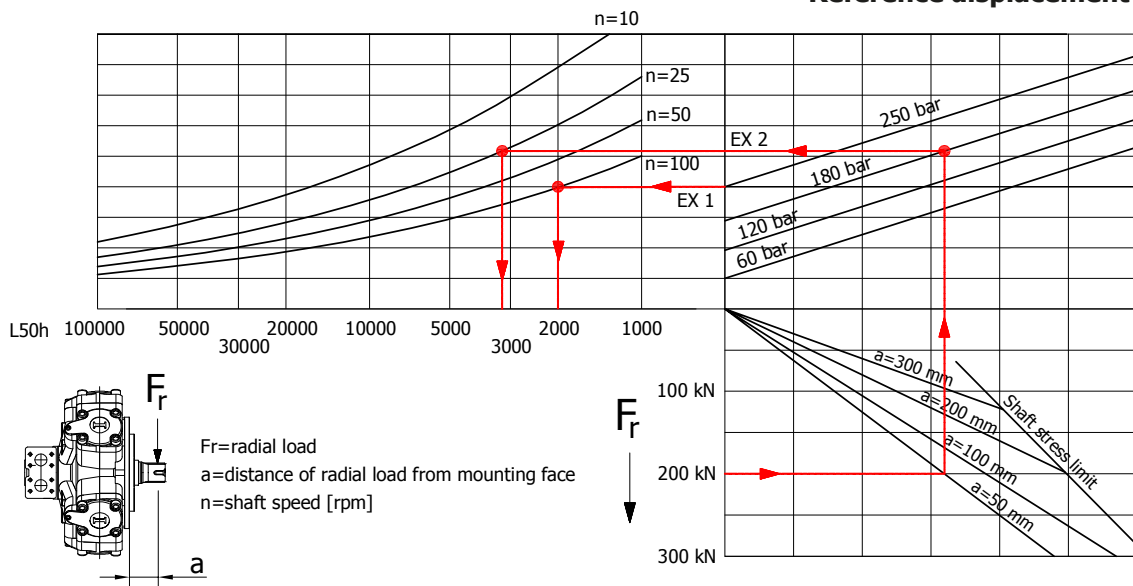

Reference viscosity: 40 cSt

Example:

We suppose (EX1): $p=250$ [bar], $n=100$ [rpm]; we obtain an average lifetime of 2000 [h].

If we suppose (EX2): $F_r=200$ [kN], $a=50$ [mm], $n=25$ [rpm] and $p=250$ [bar] we obtain an average lifetime of 3100 [h].

R8D H9 - ORDERING CODE

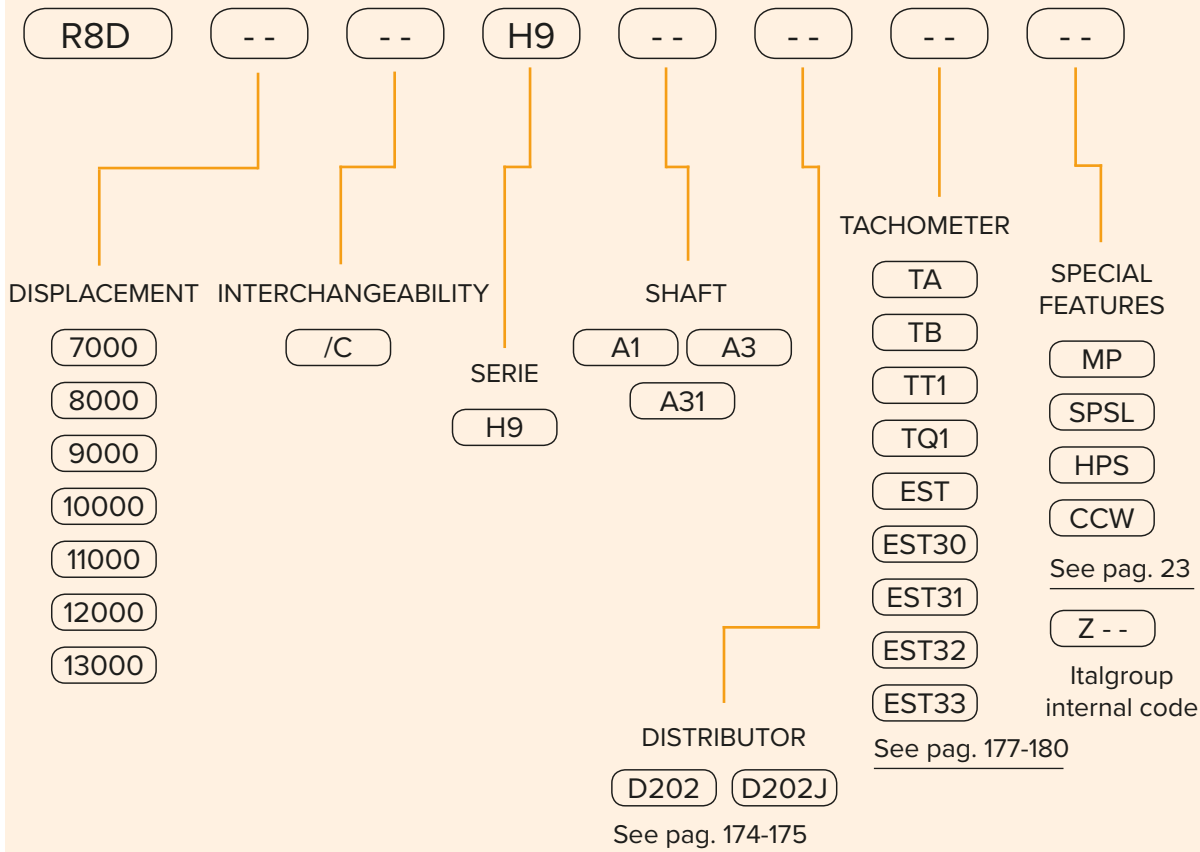

EXAMPLES:

- R8D 13000 H9 A0 D202
- R8D 8000/C A3 D202
- R8D 10000 H9 A3 D202 EST

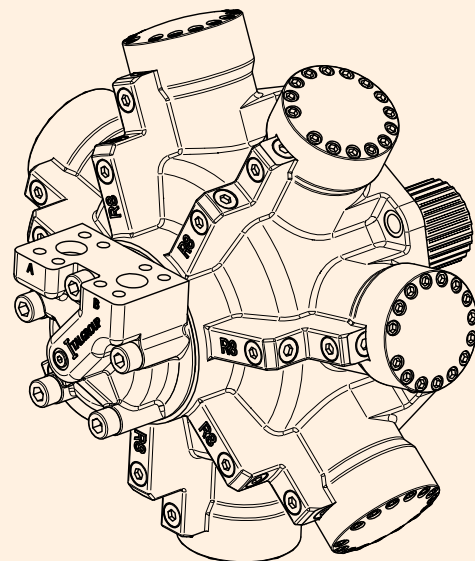

MOTOR DISTRIBUTORS

D40-D416-D31B-D310B-D36B-D316B

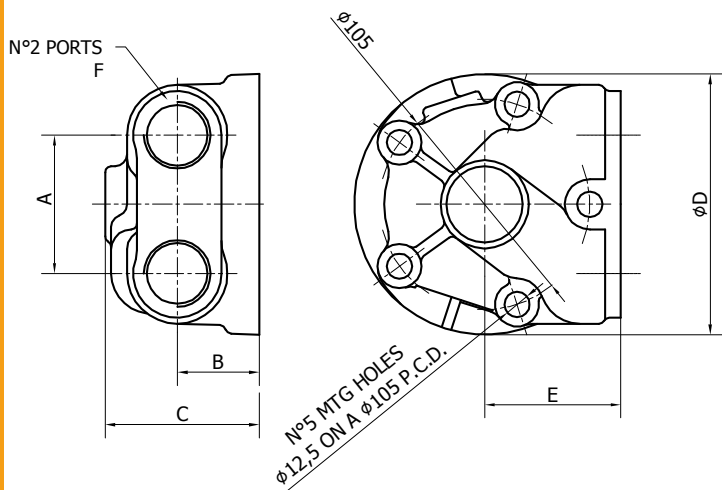

D47-D75-D90-D202

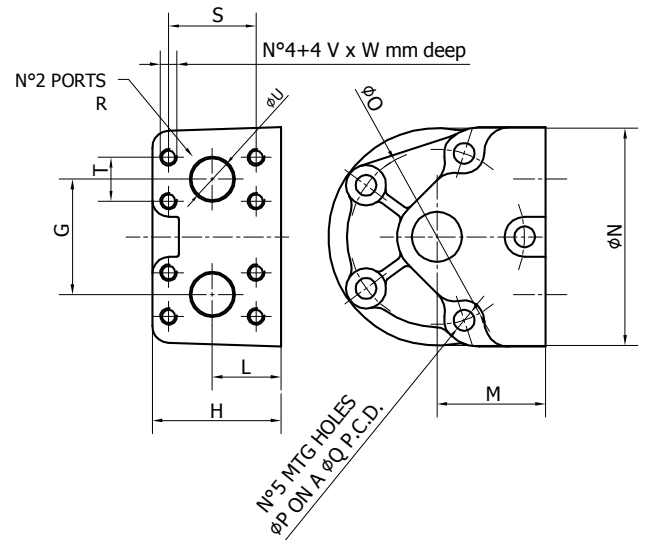

D200

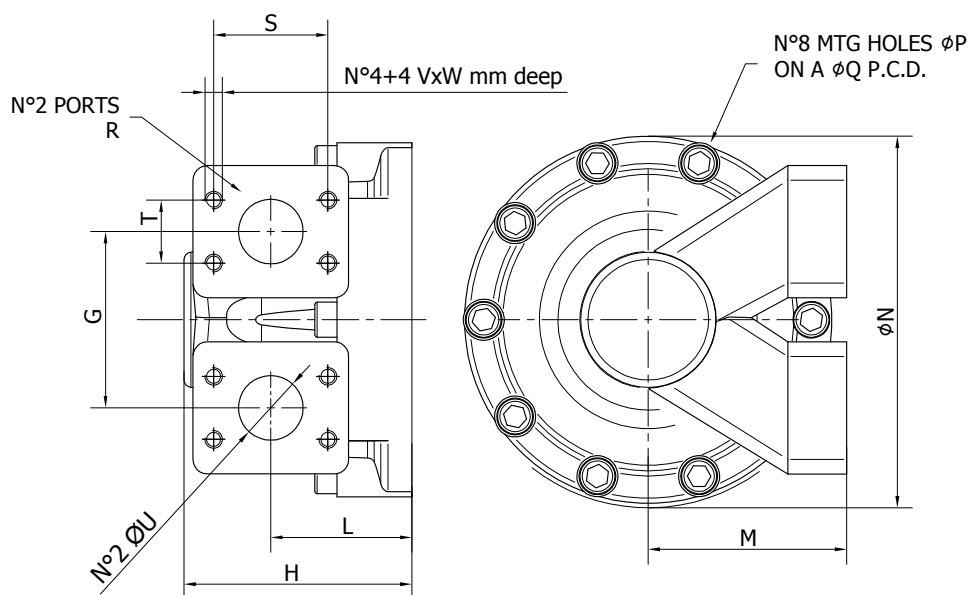

		D40	D416	D31B	D310B	D36B	D316B	D47	D75	D90	D200	D202
A	[mm]	69	69	56	56	56	56					
B	[mm]	41	41	39	39	39	39					
C	[mm]	77	77	67	67	67	67					
D	[mm]	130	130	125	125	125	125					
E	[mm]	68	68	65	65	65	65					
F	□	1" BSP	1" SAE	3/4" BSP	1" BSP	3/4" SAE	1" SAE					
G	[mm]							69	83	100	120	145
H	[mm]							77	107	113	155	162
L	[mm]							41	55	59	96	80
M	[mm]							65	92	95	135	145
N	[mm]							130	170	190	250	300
O	[mm]							105	145	149	222	240
P	[mm]							12,5	14,5	14,5	16,5	30,5
Q												
R	□							1" SAE 3000	1"1/2 SAE 3000	1"1/2 SAE 6000	2" SAE 3000	2" SAE 6000
S	[mm]							52,4	69,85	79,4	77,77	96,8
T	[mm]							26,2	35,7	36,7	42,9	44,5
U	[mm]							25	39	40	44	50
V	[mm]							M10	M12	M16	M12	M20
W	[mm]							19	22	22	24	37

		D31B	D310B	D36B	D40	D416	D47	D75	D90	D200	D202
MAX. CONT. FLOW	[l/min]	200	300	200	300	300	300	600	700	850	1000
MAX. FLOW	[l/min]	400	400	400	400	400	400	1000	1200	1500	2000
MAX. CONT. PRESSURE	[bar]	300	300	300	300	300	300	300	300	300	300
PEAK PRESSURE	[bar]	500	500	500	500	500	500	500	500	500	500

R8D H2	●	●	●	●	●	●					
R8D H3	●	●	●	●	●	●					
R8D H4	●	●	●	●	●	●					
R8D H45	●	●	●	●	●	●					
R8D H5	●	●	●	●	●	●	●	●	●		
R8D H55	●	●	●	●	●	●	●	●	●	●	
R8D H6	●	●	●	●	●	●	●	●	●	●	
R8D H7	●	●	●	●	●	●	●	●	●	●	
R8D H8										●	
R8D H9											●



Standard version



Special version: available on request. Please contact Italgroupp for more details

TACHOMETERS

J

Tacho drive plug 1/2" BSP

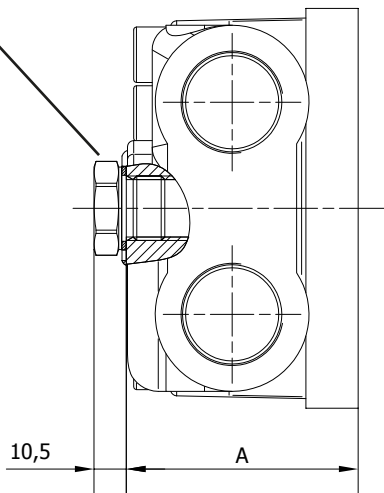

DISTRIBUTOR TYPE	A
D40/D416/D47	75,5
D31B/D310B/D36B/D316B	63,5
D75	101
D90	107

Tachometer predisposition **ONLY**

TA

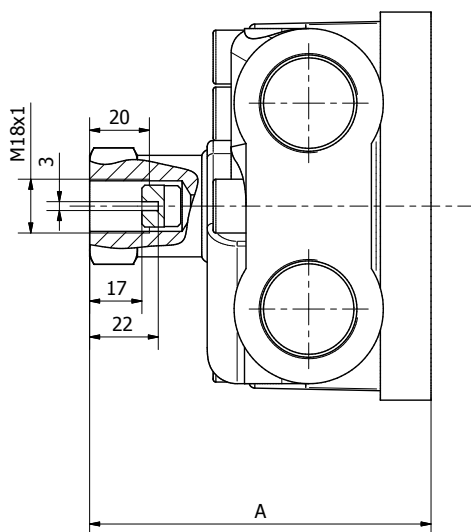

DISTRIBUTOR TYPE	A
D40/D416/D47	114,5
D31B/D310B/D36B/D316B	102,5
D75	140
D90	146

TB

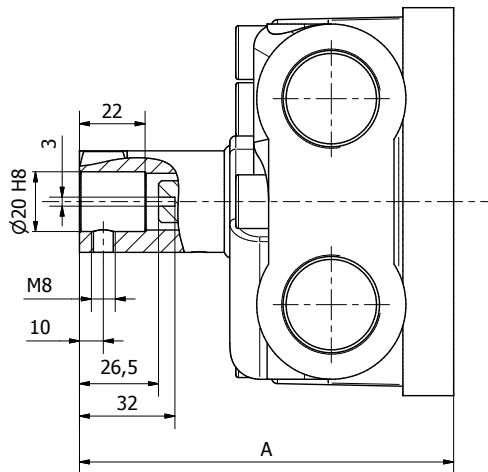

DISTRIBUTOR TYPE	A
D40/D416/D47	125,5
D31B/D310B/D36B/D316B	113,5
D75	151
D90	157

TT1

DETAIL X

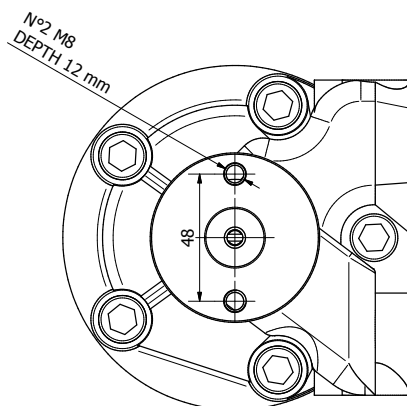
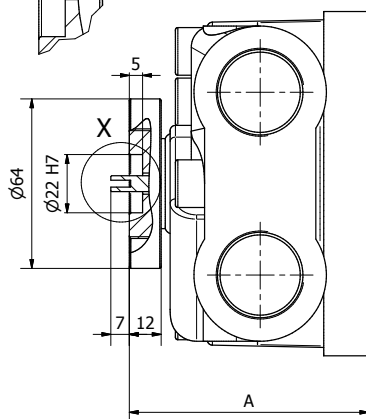
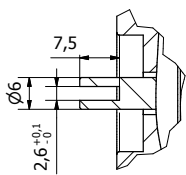

DISTRIBUTOR TYPE	A
D40/D416/D47	90,5
D31B/D310B/D36B/D316B	78,5
D75	116
D90	122

TACHOMETERS

TQ1

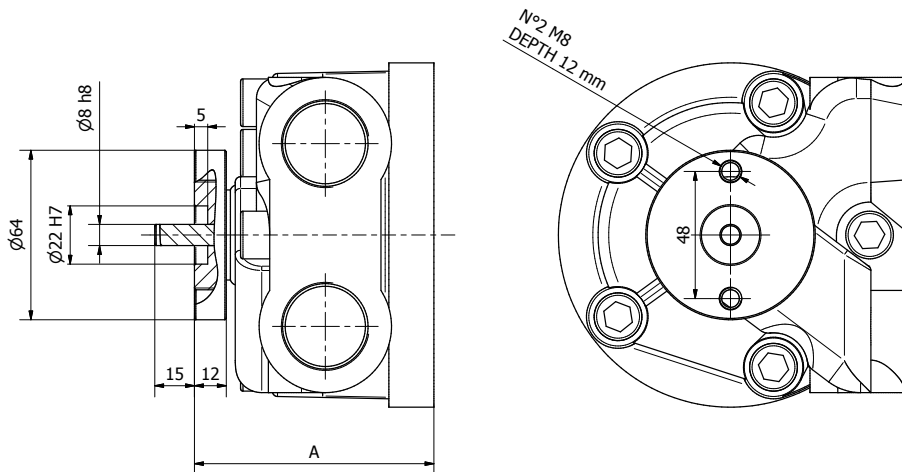

DISTRIBUTOR TYPE	A
D40/D416/D47	90,5
D31B/D310B/D36B/D316B	78,5
D75	116
D90	122

EST

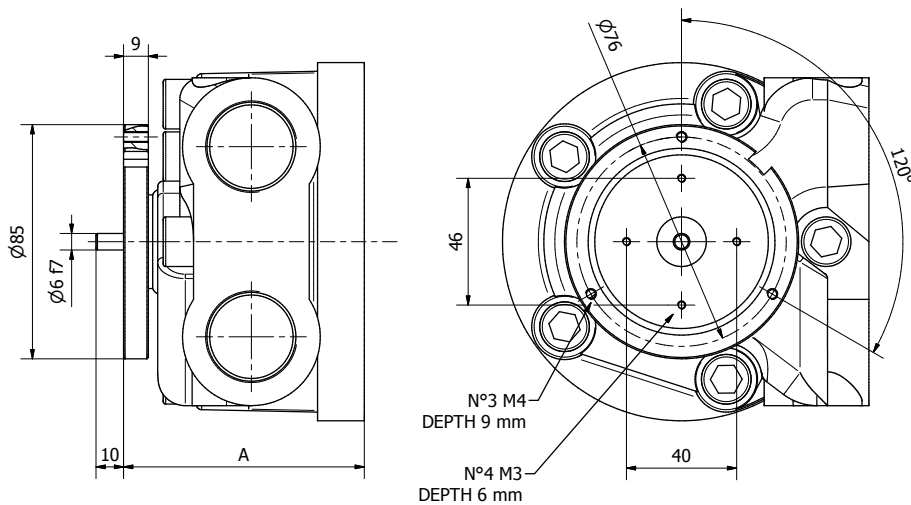

DISTRIBUTOR TYPE	A
D40/D416/D47	87,5
D31B/D310B/D36B/D316B	75,5
D75	113
D90	119

EST 30

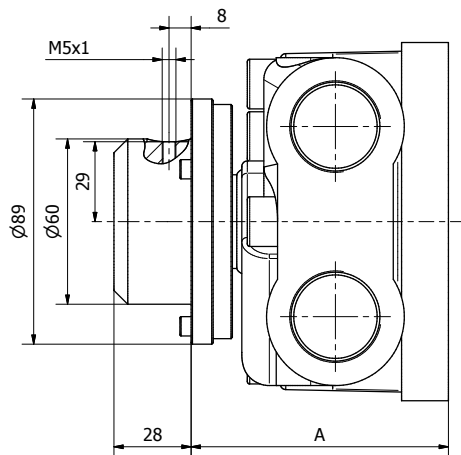

DISTRIBUTOR TYPE	A
D40/D416/D47	93,5
D31B/D310B/D36B/D316B	81,5
D75	119
D90	125

EST 30 ELECTRIC DATA	
POWER SUPPLY	10 - 30 VDC
IMPULSE / RPM	30
PROTECTION DEGREE	IP67
OUTPUT	NPN / PNP (*)

(*) Customer has to select it at the order stage. In case of non-indication by customer, NPN version will be supplied as standard.

EST 31

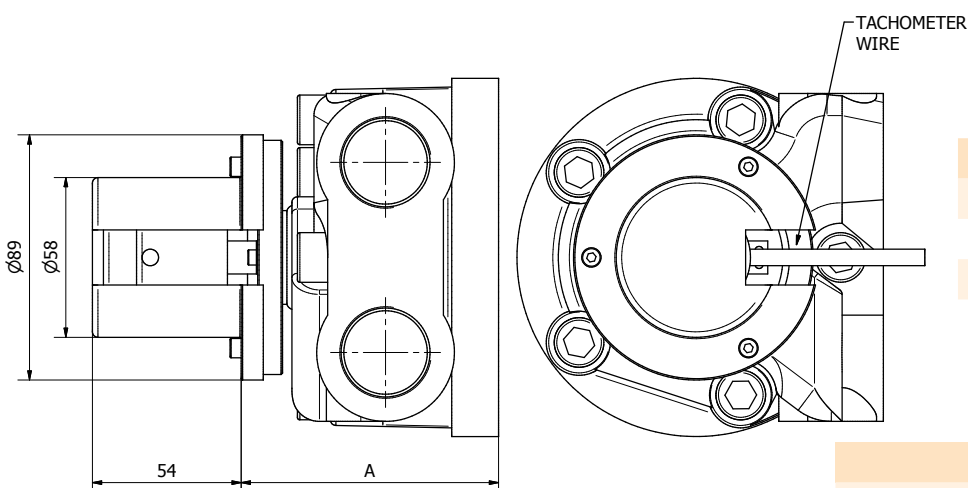

DISTRIBUTOR TYPE	A
D40/D416/D47	93,5
D31B/D310B/D36B/D316B	81,5
D75	119
D90	125

EST 31 ELECTRIC DATA	
POWER SUPPLY	8 - 24 VDC
IMPULSE / RPM	500
PROTECTION DEGREE	IP65
OUTPUT	PUSH-PULL

TACHOMETERS

EST 32

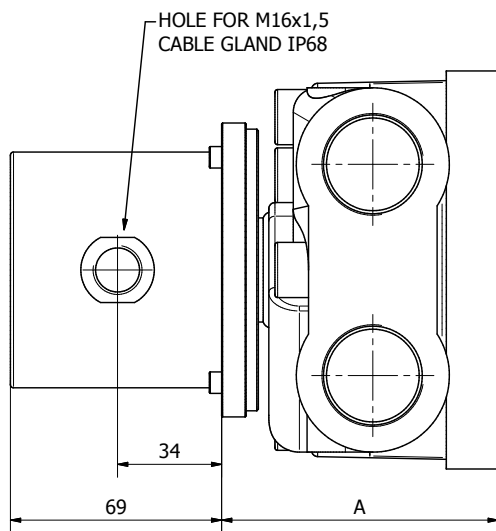

DISTRIBUTOR TYPE	A
D40/D416/D47	93,5
D31B/D310B/D36B/D316B	81,5
D75	119
D90	125

EST 32 ELECTRIC DATA	
POWER SUPPLY	8 - 24 VDC
IMPULSE / RPM	4096
PROTECTION DEGREE	IP67
OUTPUT	SSI interface

EST 33

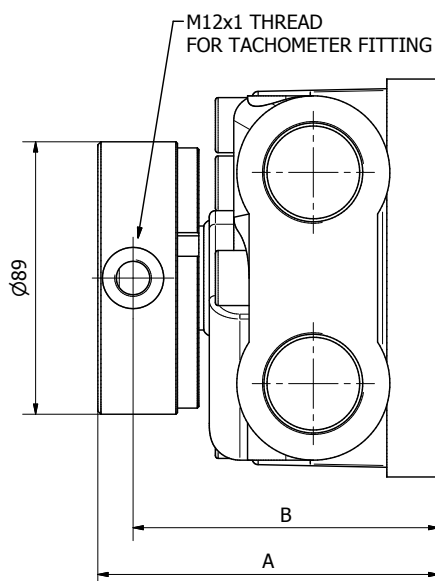

DISTRIBUTOR TYPE	A	B
D40/D416/D47	99,5	88
D31B/D310B/D36B/D316B	87,5	76
D75	125	113,5
D90	131	119,5

SENSOR NOT INCLUDED

SPLINE BILLETS

SB1

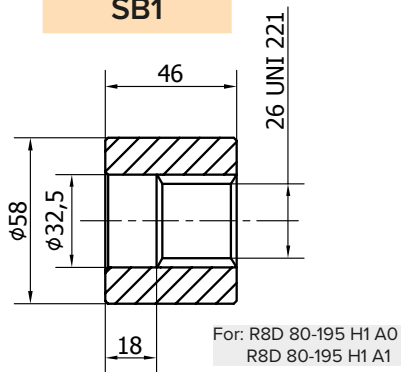

SB2

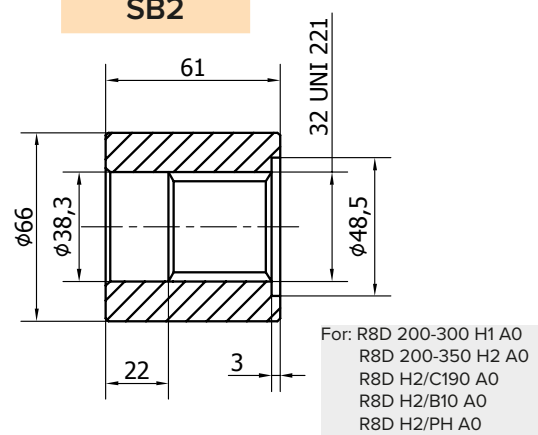

SB3

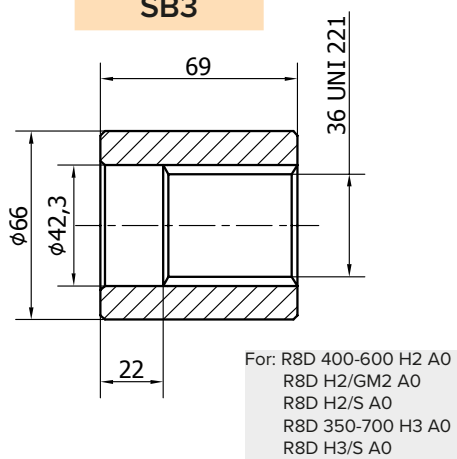

SB4

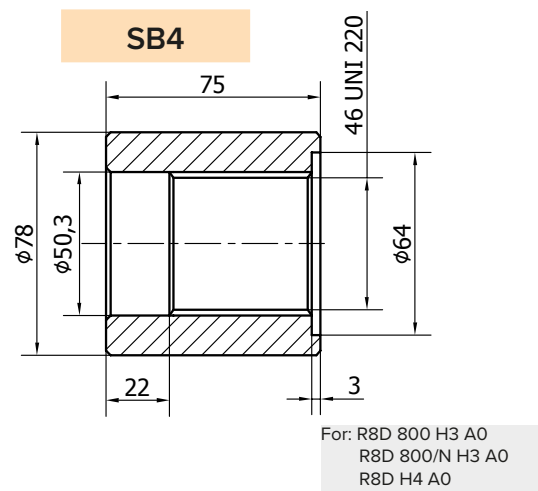

SB5

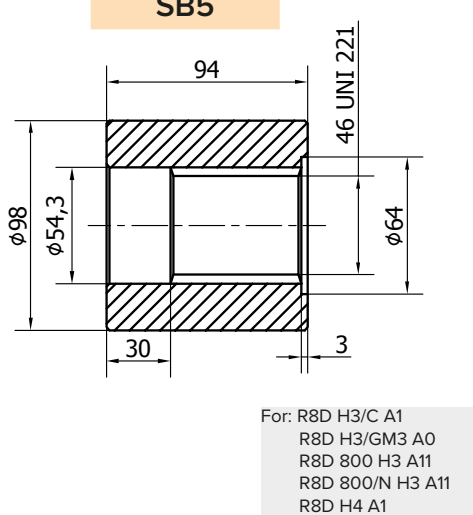

SB6

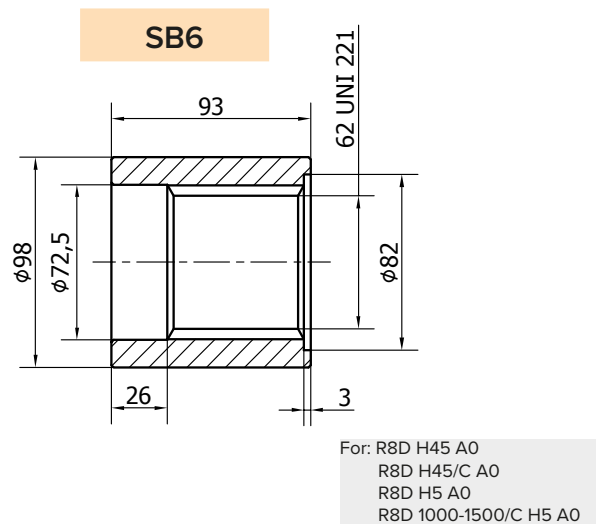

SPLINED BILLETS

SB7

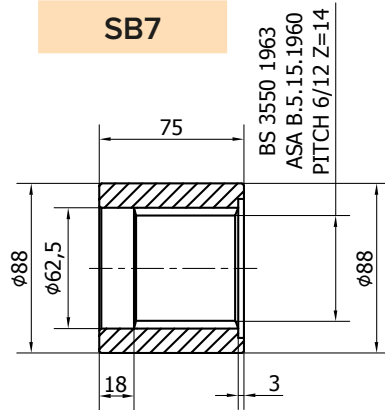

For: R8D H45 A1
R8D H5 A1

SB8

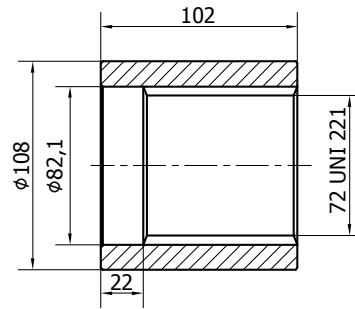

For: R8D 1600-2200/C A0

SB9

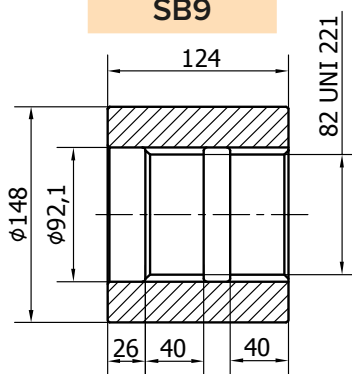

For: R8D H55 A0
R8D H55/C A0
R8D H6 A0
R8D H6/C A0

SB10

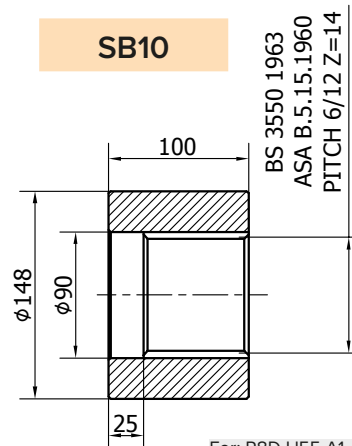

For: R8D H55 A1
R8D H6 A1
R8D H7 A1

SB11

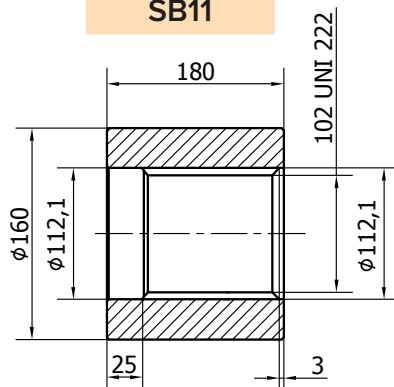

For: R8D H7 A0
R8D H7/C A0

SB14

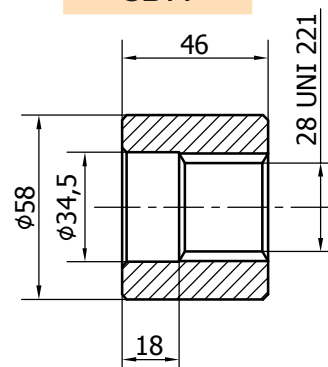

For: R8D H1/GM05 A0
R8D H1/GM1 A0
R8D H1/BH A0
R8D H1 A11

SB15

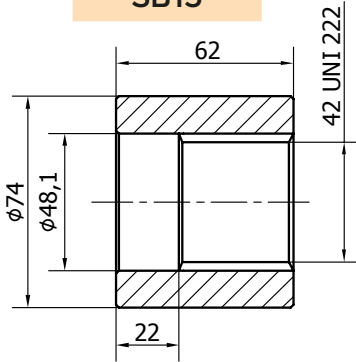

For: R8D H2/C300 A0

SB16

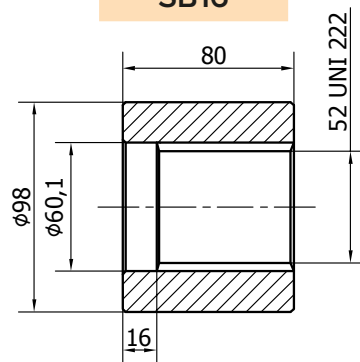

For: R8D H4/C A0

SB17

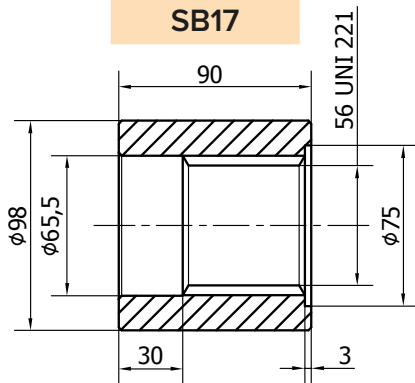

For: R8D H4/S A0
R8D H4/GM4 A0
R8D H5/GM5 A0

SB21

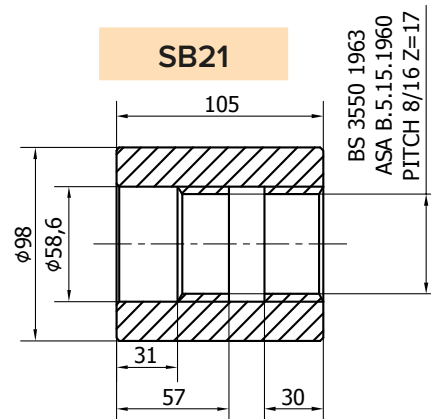

For: R8D H3/B30 A0
R8D H4/B45 A1

SB24

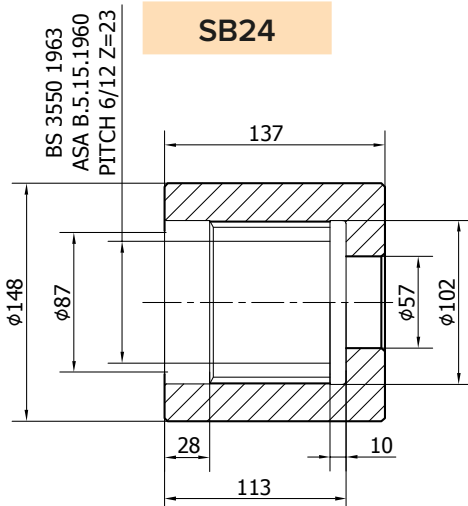

For: R8D H6 A11
R8D H7 A13

SB27

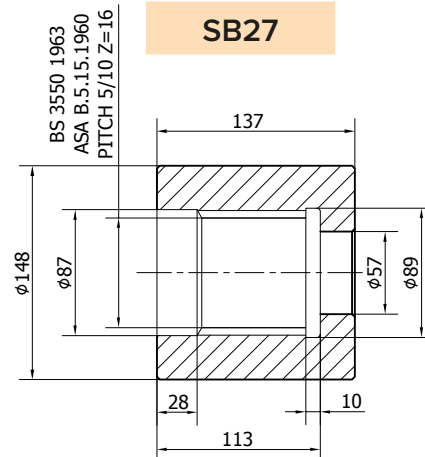

For: R8D H6 A12
R8D H7 A12

SPLINED BILLETS

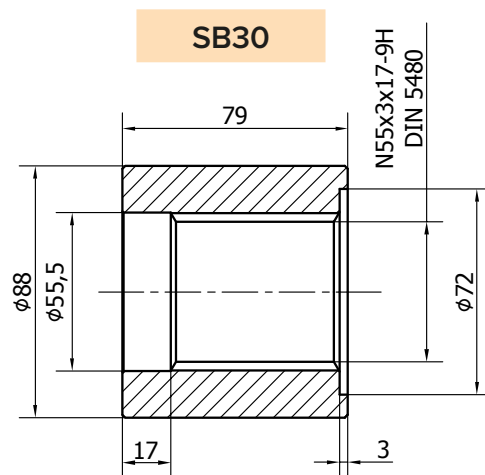

For: R8D H3/B30 A1
R8D H3/C A11
R8D H4/B45 A4

SPLINED BARS

B8076

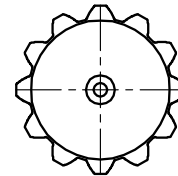
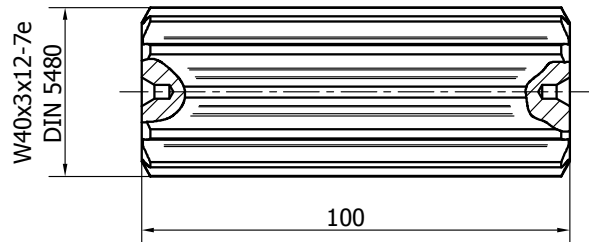

For: R8D H3 A31
R8D H3/GM3 A31
R8D H3/S A31

B8078

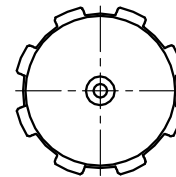
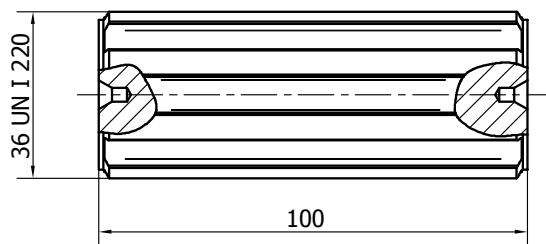

For: R8D 200-350 H2 A3
R8D 400-600 H2 A3
R8D H2/GM2 A3
R8D H2/S A3
R8D H3 A3
R8D H3/GM3 A3
R8D H3/S A3

B8079

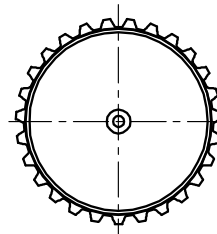
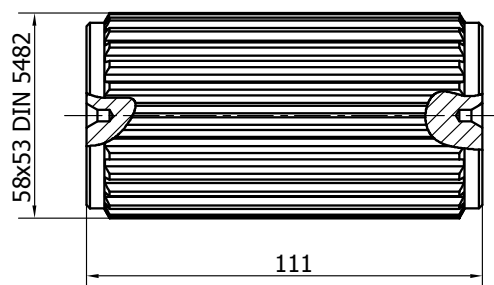

For: R8D H4 A3

ADAPTOR FLANGES

FL1

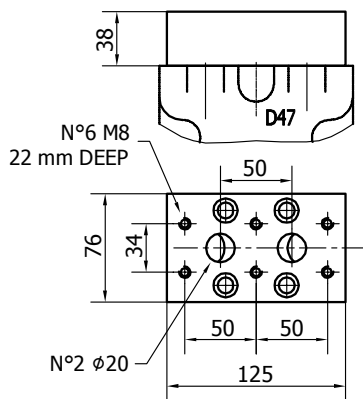

Connection block, fitting D47 distributor, for motor MR125/160/190/200/250/300/330

FL2

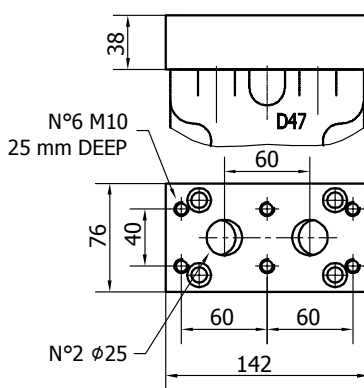

Connection block, fitting D47 distributor, for motor MR350/450/500/600/700/800

FL4

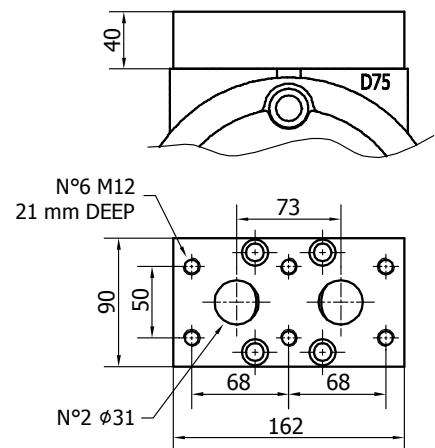

Connection block, fitting D75 distributor, for motor MR1100/1400/1600/1800/2100

FL5

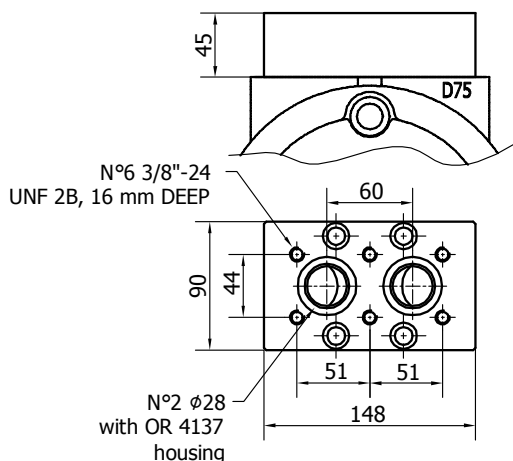

Connection block, fitting D75 distributor, for motor HMB 60/80/100 - S03

FL6

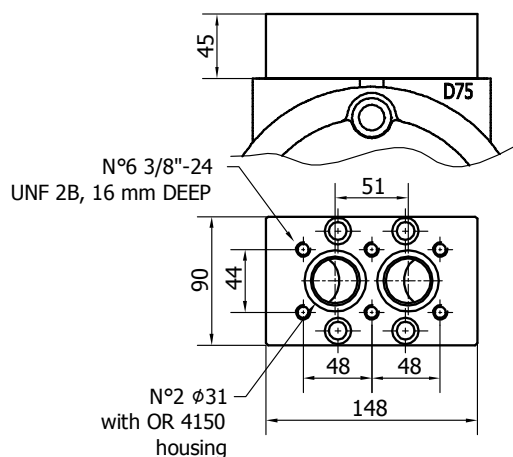

Connection block, fitting D75 distributor, for motor HMB 60/80/100 - S04

FL7

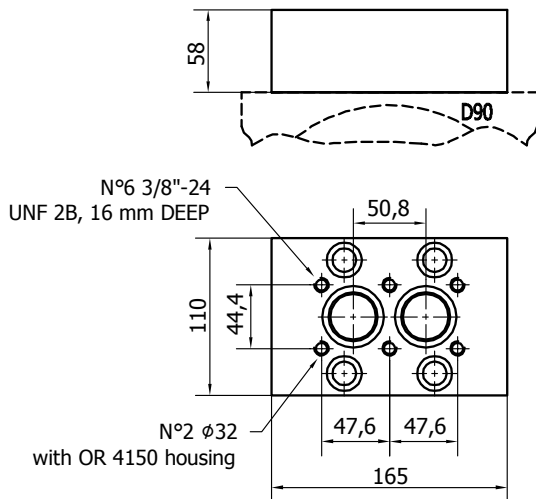

Connection block, fitting D90 distributor, for motor HMB 125/150/200 - S04

FL8

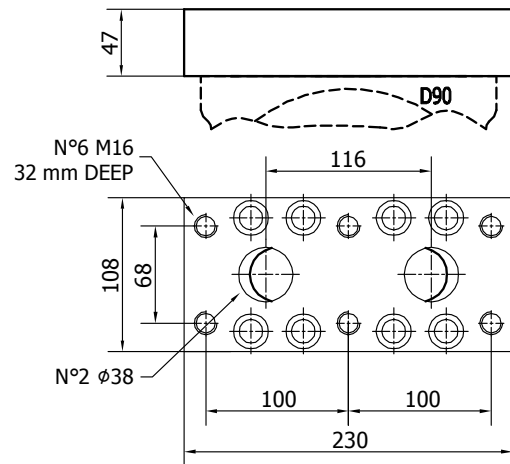

Connection block, fitting D90 distributor, for motor MR 3600/4500, MRE 5400

FL10

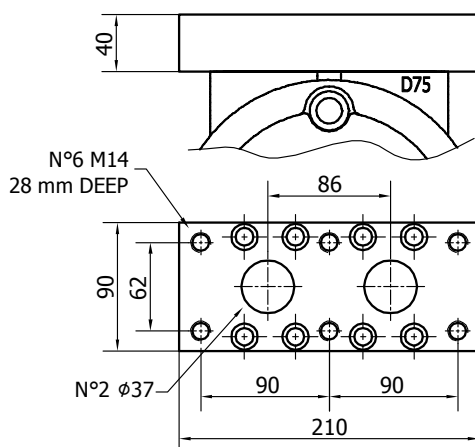

Connection block, fitting D75 distributor, for motor MR 2400/2800, MRE 3100

FL16

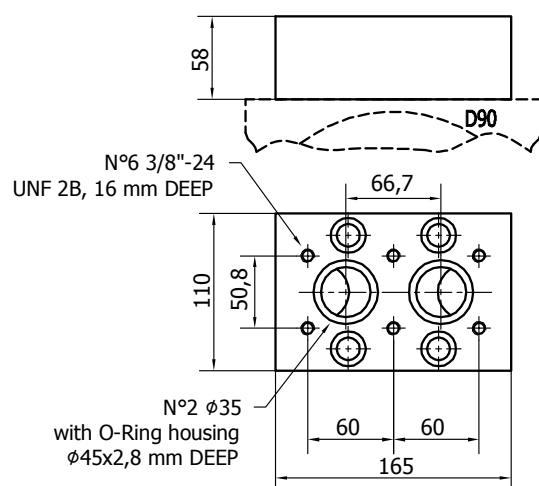

Connection block, fitting D90 distributor, for motor HMB 270/325 - S04

R8D - VALVES

SINGLE OVERCENTER - OVSA 160	Pag. 190
DOUBLE OVERCENTER - OVDA 160	Pag. 191
FLUSHING - AP 40	Pag. 192
DOUBLE RELIEF - RVDA 80	Pag. 193
ANTICAVITATION - AC 80	Pag. 194
DOUBLE RELIEF AND ANTICAVITATION - RVDAC 80	Pag. 195
DOUBLE RELIEF AND FLUSHING - RVDAP 80	Pag. 196
SINGLE RELIEF AND ANTICAVITATION - RVSAC 200	Pag. 197
DOUBLE OVERCENTER - OVDA 300	Pag. 198
DOUBLE RELIEF - RVDA 200	Pag. 199
SINGLE RELIEF AND OVERCENTER - ORVSA 200	Pag. 200
DOUBLE RELIEF AND SINGLE OVERCENTER - DRVSO200EP	Pag. 201
DOUBLE OVERCENTER - OVDA 480	Pag. 202
DOUBLE RELIEF - RVDA 380	Pag. 203
SINGLE RELIEF AND OVERCENTER - ORVSA 480	Pag. 204
DOUBLE RELIEF AND FLUSHING - RVDAP 90	Pag. 205
VALVES ORDERING CODE	Pag. 206

SINGLE OVERCENTER - OVSA 160

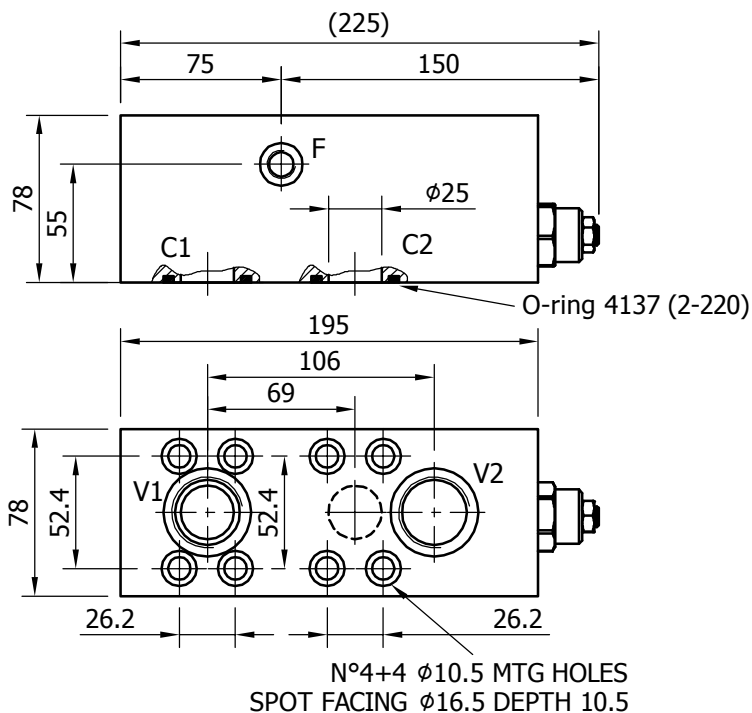
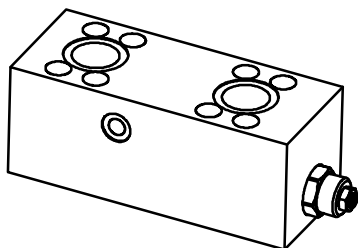

PORTS DIMENSION

V1, V2 1" BSP

F 1/4" BSP

C1, C2 O-Ring 4137
Parker code 2-220

TECHNICAL DATA

		OVSA.160.1.D47	OVSA.160.2.D47	OVSA.160.3.D47
NOMINAL FLOW	[l/min]	120	120	120
MAXIMUM FLOW	[l/min]	160	160	160
MAXIMUM PRESSURE	[bar]	350	350	350
PILOT RATIO	□	1 (3:1)	2 (4.5:1)	3 (10:1)
RELIEF VALVE SETTING RANGE	[bar]	70-280	140-350	140-350
STANDARD RELIEF SETTING	[bar]	210	210	210
BLOCK MATERIAL	□	steel	steel	steel
DISTRIBUTOR FITTING	□	D47	D47	D47

Cartridge characteristic

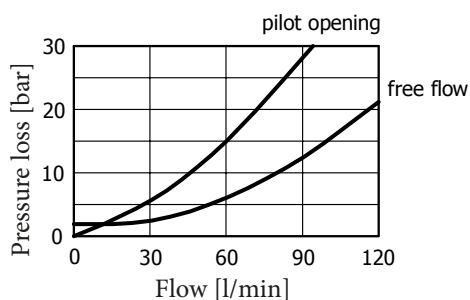

Hydraulic circuit

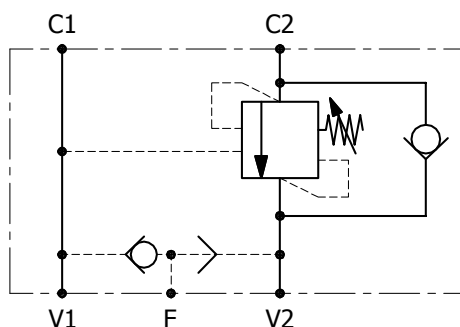

DOUBLE OVERCENTER - OVDA 160

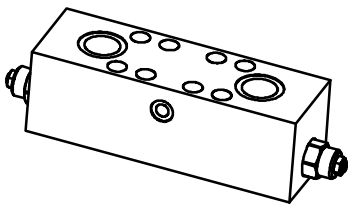

PORTS DIMENSION	
V1, V2	1" BSP
F	1/4" BSP
C1, C2	O-Ring 4137 Parker code 2-220

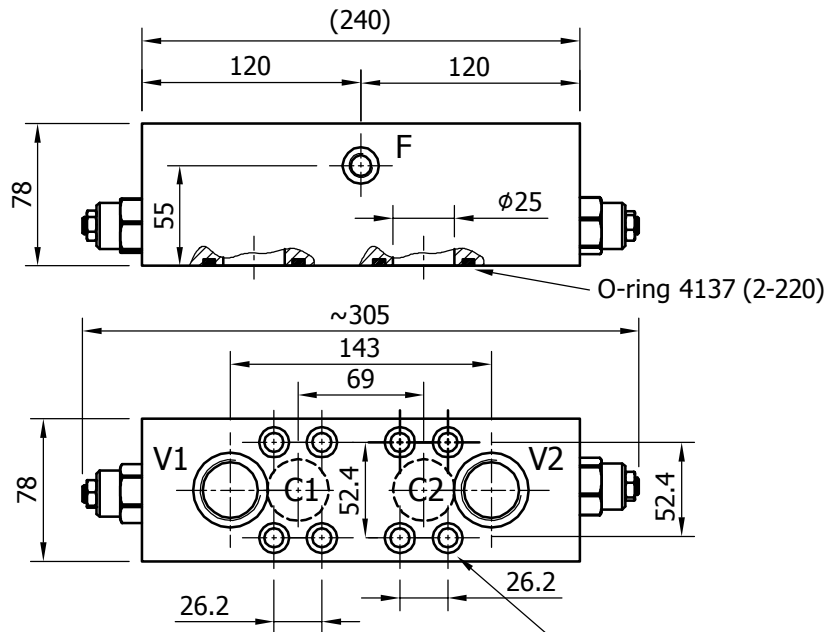

N°4+4 ϕ 10.5 MTG HOLES
SPOT FACING ϕ 16.5 DEPTH 10.5

TECHNICAL DATA

		OVDA.160.1.D47	OVDA.160.2.D47	OVDA.160.3.D47
NOMINAL FLOW	[l/min]	120	120	120
MAXIMUM FLOW	[l/min]	160	160	160
MAXIMUM PRESSURE	[bar]	350	350	350
PILOT RATIO	[]	1 (3:1)	2 (4.5:1)	3 (10:1)
RELIEF VALVE SETTING RANGE	[bar]	70-280	40-350	140-350
STANDARD RELIEF SETTING	[bar]	210	210	210
BLOCK MATERIAL	[]	steel	steel	steel
DISTRIBUTOR FITTING	[]	D47	D47	D47

Cartridge characteristic

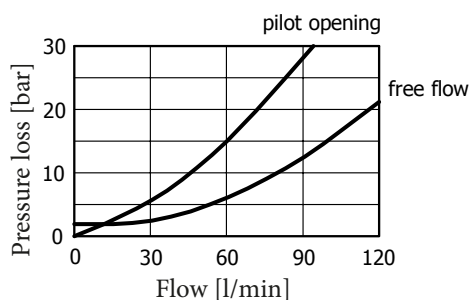

Hydraulic circuit

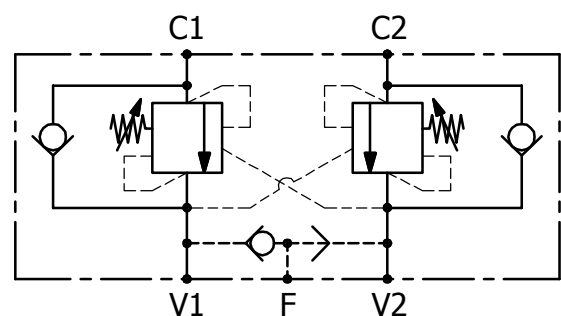

FLUSHING - AP 40

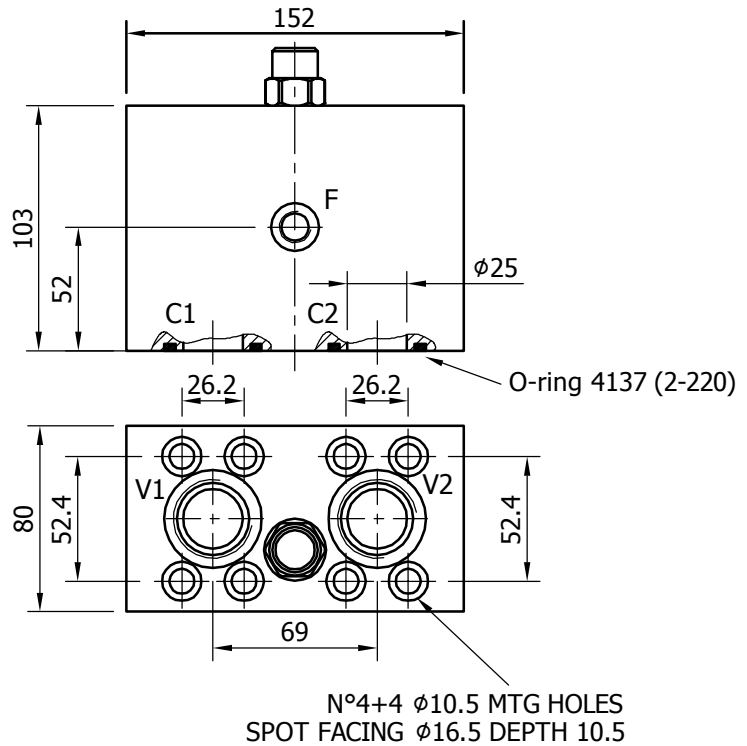
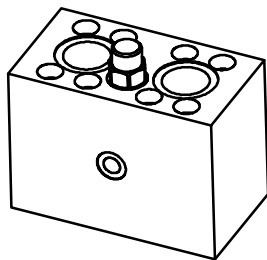

PORTS DIMENSION

V1, V2	1" BSP
F	1/4" BSP
C1, C2	O-Ring 4137 Parker code 2-220

TECHNICAL DATA

		AP40.D47
MAXIMUM FLUSHING FLOW	[l/min]	80
MAXIMUM PRESSURE	[bar]	350
BLOCK MATERIAL	□	steel
DISTRIBUTOR FITTING	□	D47

Cartridge characteristic

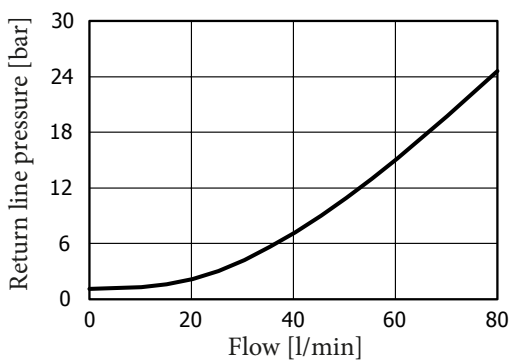

Hydraulic circuit

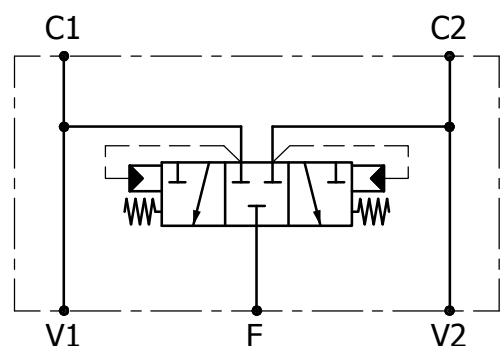

DOUBLE RELIEF - RVDA 80

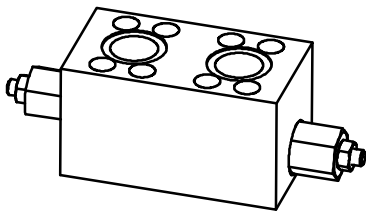

PORTS DIMENSION

V1, V2	1" BSP
C1, C2	O-Ring 4137 Parker code 2-220

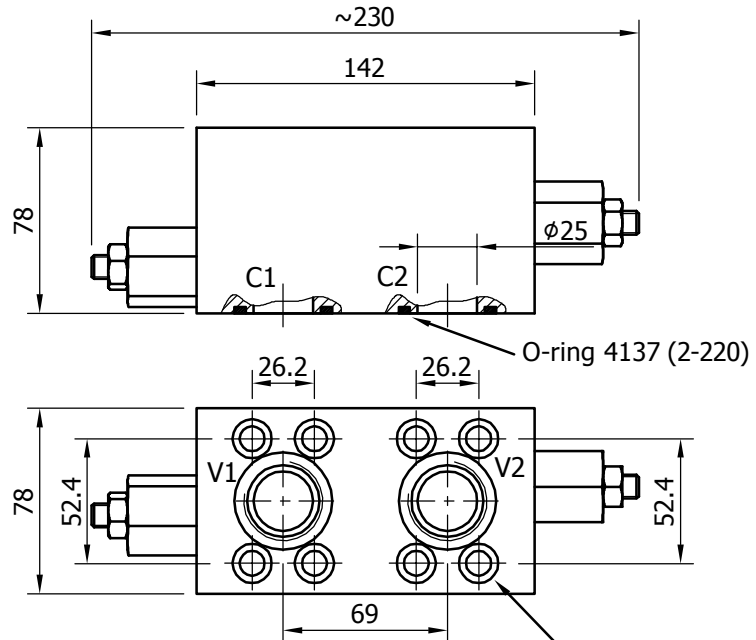

N°4+4 $\phi 10.5$ MTG HOLES
SPOT FACING $\phi 16.5$ DEPTH 10.5

TECHNICAL DATA

RVDA.80.C.D47

NOMINAL FLOW	[l/min]	150
MAXIMUM FLOW	[l/min]	200
MAXIMUM PRESSURE	[bar]	350
RELIEF VALVE SETTING RANGE	[bar]	C (20-350)
STANDARD RELIEF SETTING	[bar]	20
BLOCK MATERIAL	[]	steel
DISTRIBUTOR FITTING	[]	D47

Cartridge typical pressure rise

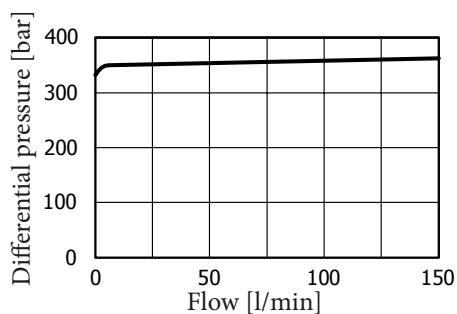

Hydraulic circuit

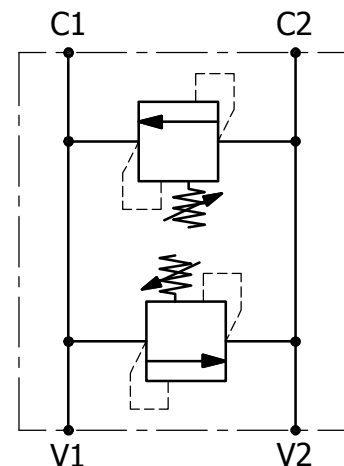

ANTICAVITATION - AC 80

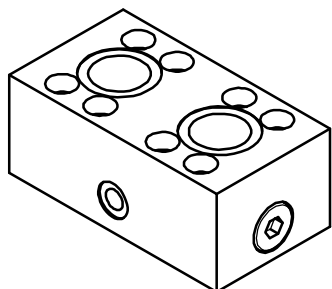

PORTS DIMENSION	
V1, V2	1" BSP
AC	1/4" BSP
C1, C2	O-Ring 4137 Parker code 2-220

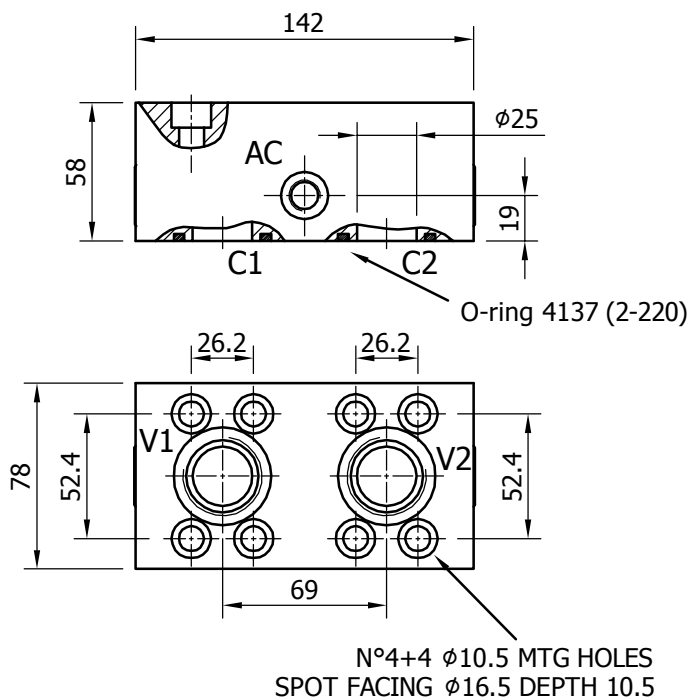

TECHNICAL DATA

		AC80.D47
NOMINAL FLOW	[l/min]	150
MAXIMUM FLOW	[l/min]	200
MAXIMUM PRESSURE	[bar]	350
MAXIMUM ANTICAVITATION FLOW (FROM AC TO C1 OR C2)	[l/min]	50
BLOCK MATERIAL	□	steel
DISTRIBUTOR FITTING	□	D47

Check valve flow/pressure curve

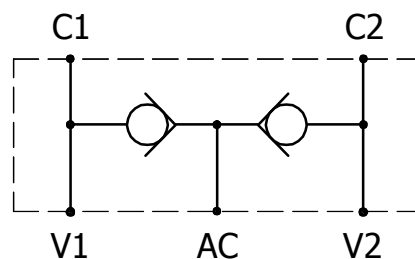
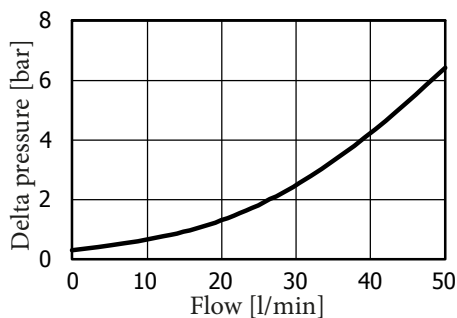

RELIEF & ANTICAVITATION - RVDAC80

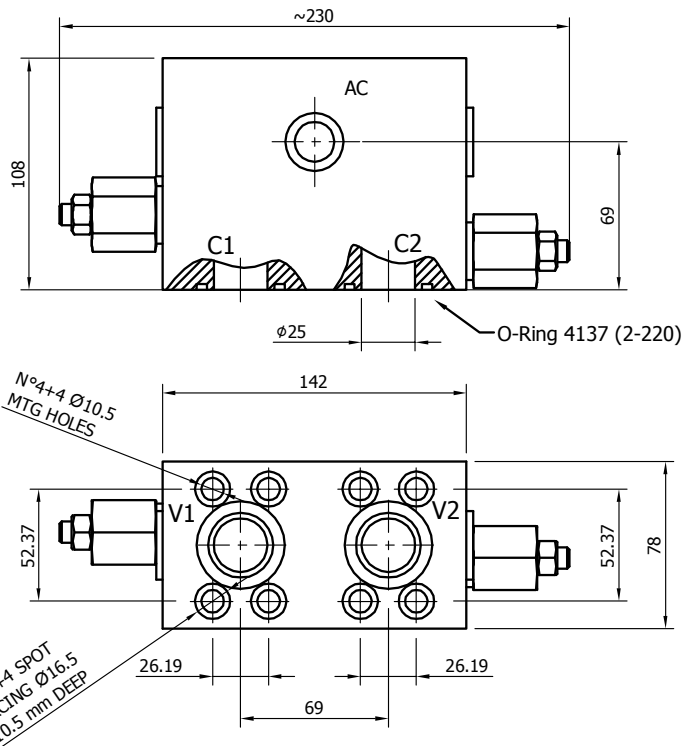
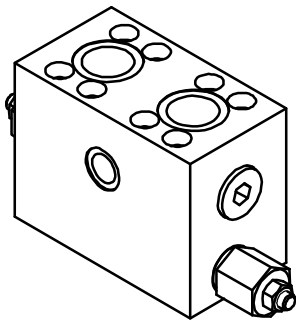

PORTS DIMENSION

V1, V2	1" BSP
AC	1/4" BSP
C1, C2	O-Ring 4137 Parker code 2-220

TECHNICAL DATA

RVDAC80.C.D47

NOMINAL FLOW	[l/min]	150
MAXIMUM FLOW	[l/min]	200
MAXIMUM PRESSURE	[bar]	350
RELIEF VALVE SETTING RANGE	[bar]	C (20-350)
STANDARD RELIEF SETTING	[bar]	20
MAXIMUM ANTICAVITATION FLOW (FROM AC TO C1 OR C2)	[l/min]	50
BLOCK MATERIAL	□	steel
DISTRIBUTOR FITTING	□	D47

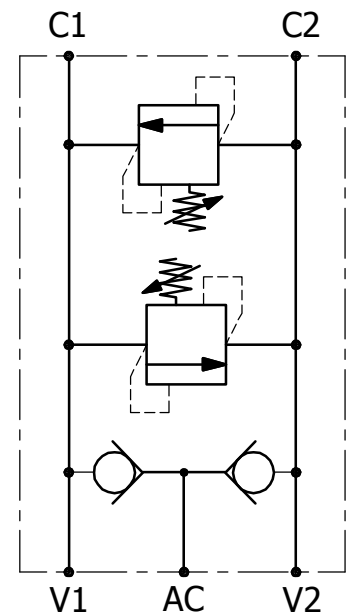

Relief cartridge typical pressure rise

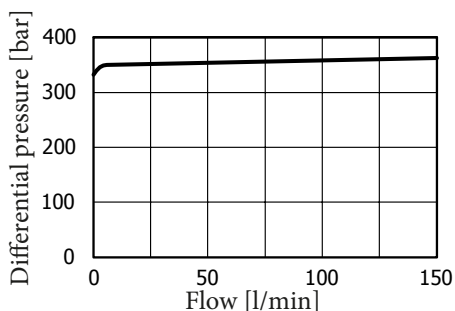

Check valve flow/pressure curve

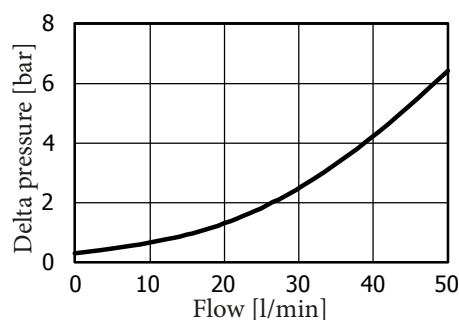

RELIEF & FLUSHING - RVDAP80

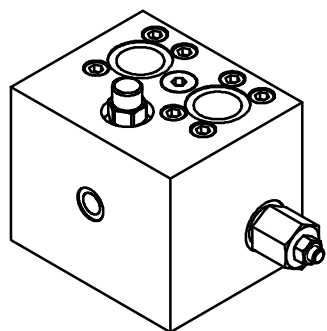

PORTS DIMENSION

V1, V2	1" BSP
F	1/4" BSP
C1, C2	O-Ring 4137 Parker code 2-220

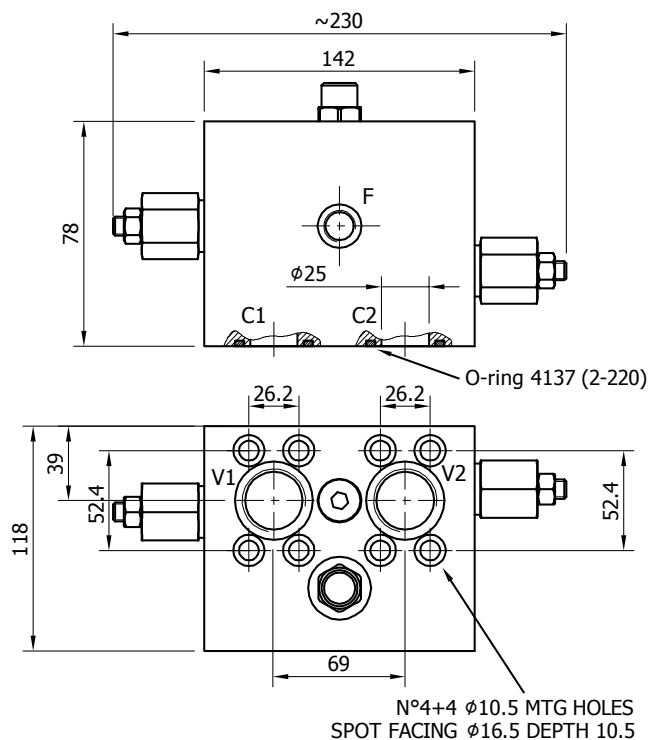

TECHNICAL DATA

		RVDAP80.C.D47
RELIEF VALVE MAXIMUM FLOW	[l/min]	200
RELIEF VALVE SETTING RANGE	[bar]	C (20-350)
STANDARD RELIEF SETTING	[bar]	70
MAXIMUM FLUSHING FLOW	[l/min]	80
MAXIMUM PRESSURE	[bar]	350
BLOCK MATERIAL	□	steel
DISTRIBUTOR FITTING	□	D47

Hydraulic circuit

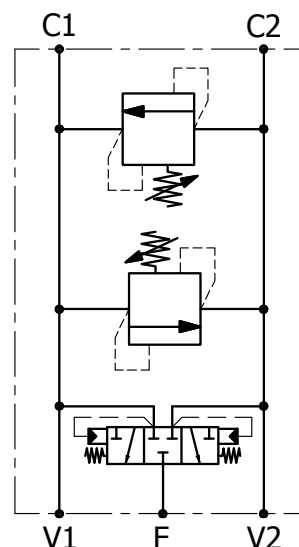

Relief cartridge typical pressure rise

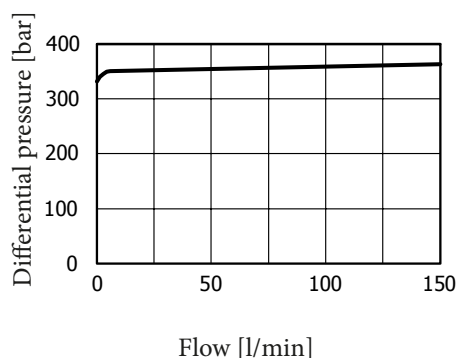

Flushing valve characteristic

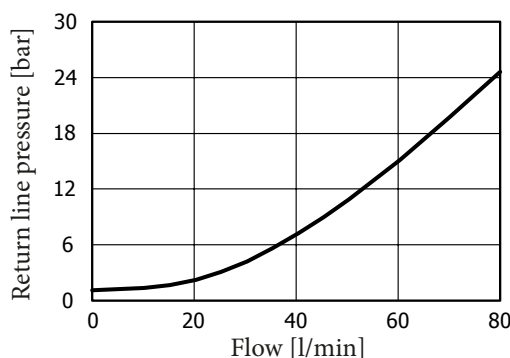

RELIEF & ANTICAVITATION - RVSAC200

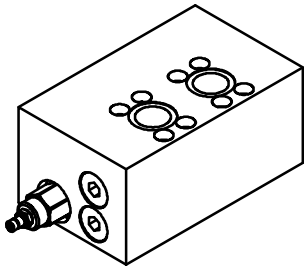

PORTS DIMENSION	
V1, V2	1" BSP
M1, M2	1/4" BSP
C1, C2	O-Ring 4137 Parker code 2-220

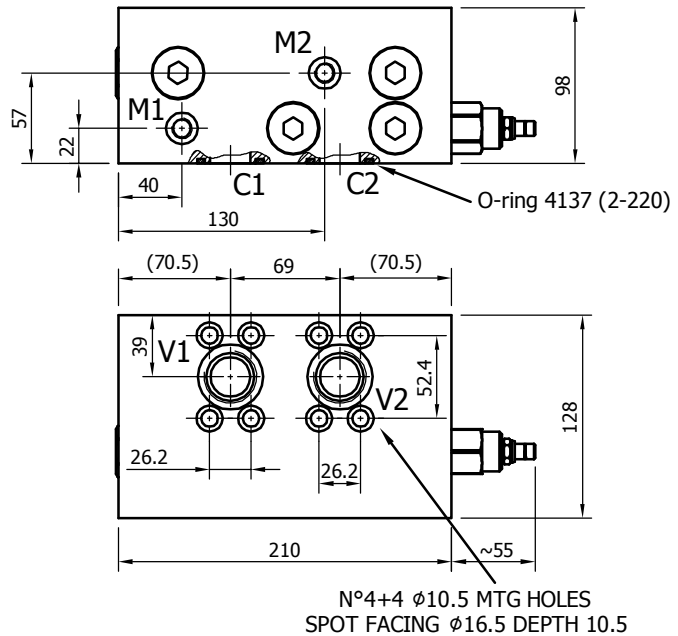

TECHNICAL DATA

RVSAC200.C.D47		
RELIEF VALVE MAXIMUM FLOW	[l/min]	200
MAXIMUM PRESSURE	[bar]	350
RELIEF VALVE SETTING RANGE	[bar]	C (70-420)
STANDARD RELIEF SETTING	[bar]	70
CHECK VALVE MAXIMUM FLOW	[l/min]	160
BLOCK MATERIAL	□	steel
DISTRIBUTOR FITTING	□	D47

Relief cartridge typical pressure rise

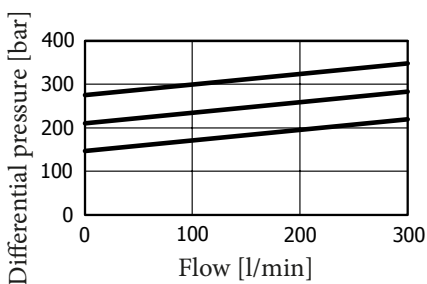

Oil supply flow (from C2 to C1)

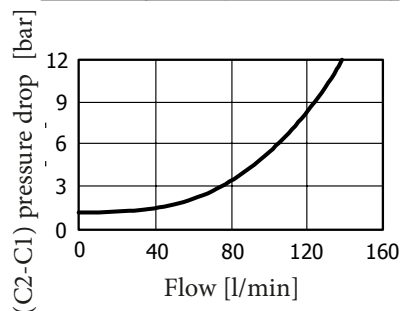

Hydraulic circuit

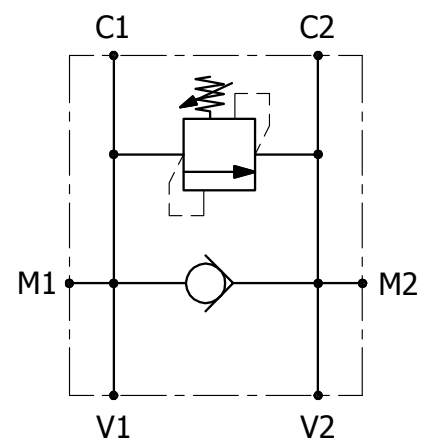

DOUBLE OVERCENTER - OVDA 300

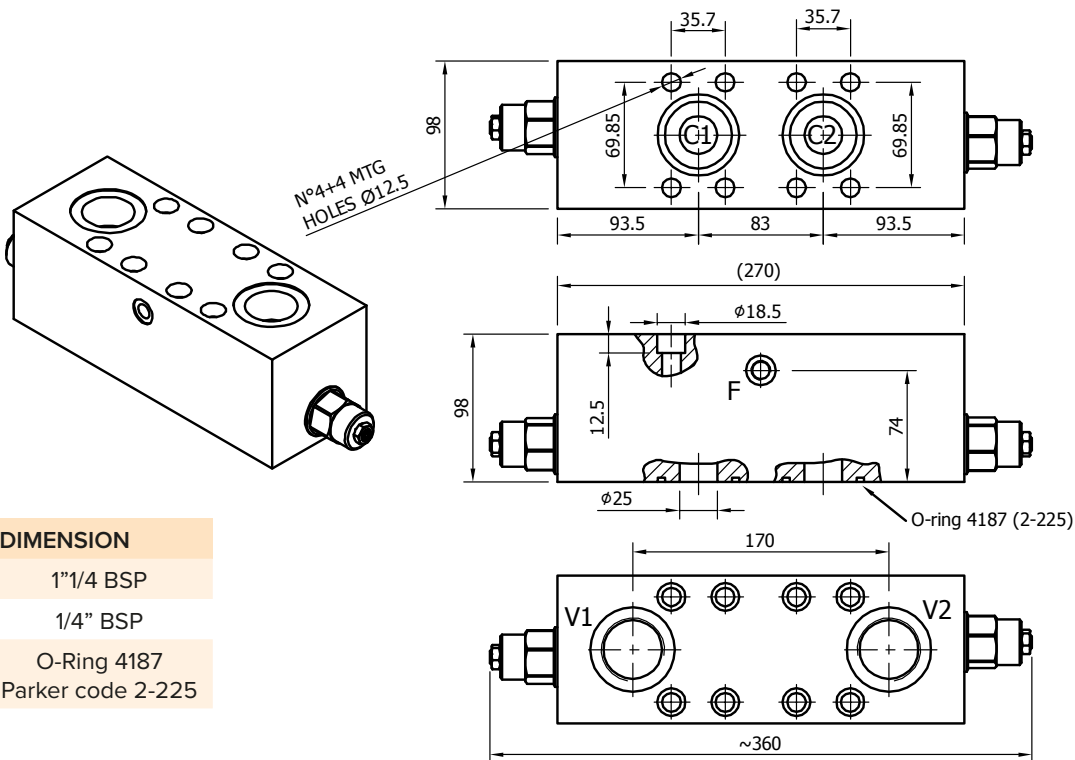

PORTS DIMENSION

V1, V2	1"1/4 BSP
F	1/4" BSP
C1, C2	O-Ring 4187 Parker code 2-225

TECHNICAL DATA

		OVDA.300.1.D75	OVDA.300.4.D75	OVDA.300.2.D75
NOMINAL FLOW	[l/min]	240	240	240
MAXIMUM FLOW	[l/min]	300	300	300
MAXIMUM PRESSURE	[bar]	350	350	350
PILOT RATIO	□	1 (3:1)	4 (10:1)	2 (4.5:1)
RELIEF VALVE SETTING RANGE	[bar]	70-280	140-350	140-350
STANDARD RELIEF SETTING	[bar]	210	210	210
BLOCK MATERIAL	□	steel	steel	steel
DISTRIBUTOR FITTING	□	D75	D75	D75

Cartridge characteristic

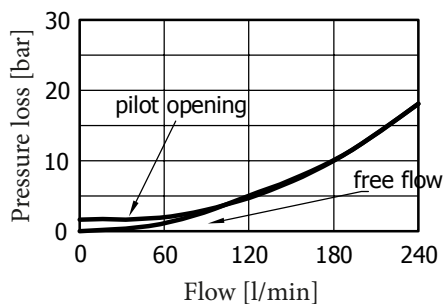

Hydraulic circuit

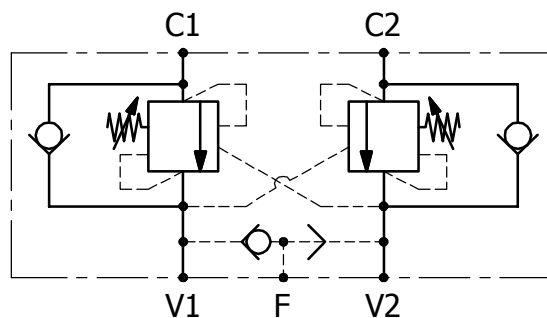

DOUBLE RELIEF - RVDA 200

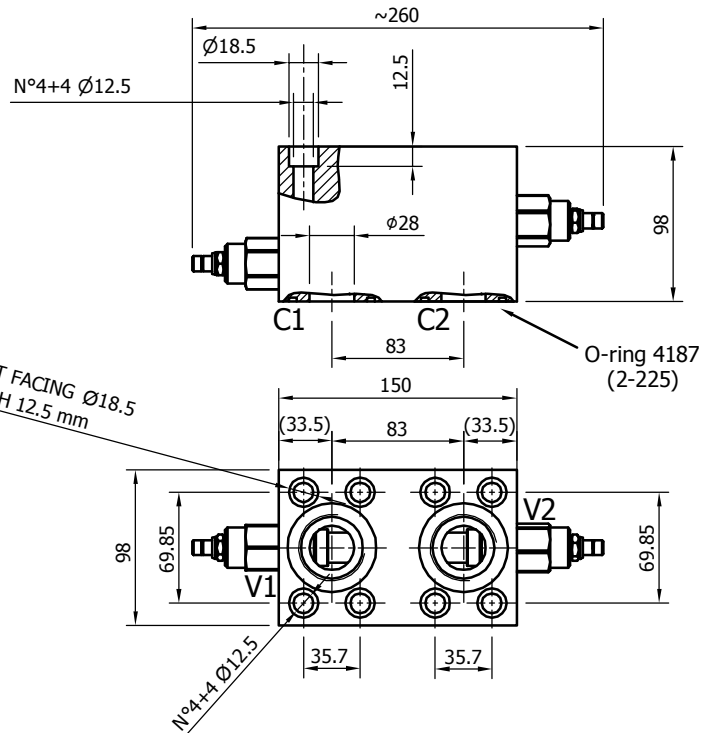
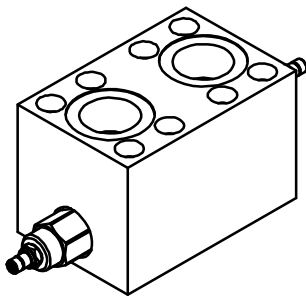

PORTS DIMENSION

V1, V2	1"1/4 BSP
C1, C2	O-Ring 4187 Parker code 2-225

TECHNICAL DATA

RVDA.200.C.D75

RELIEF VALVE MAXIMUM FLOW	[l/min]	200
MAXIMUM PRESSURE	[bar]	350
RELIEF VALVE SETTING RANGE	[bar]	C (70-420)
STANDARD RELIEF SETTING	[bar]	70
BLOCK MATERIAL	□	steel
DISTRIBUTOR FITTING	□	D75

Cartridge typical pressure rise

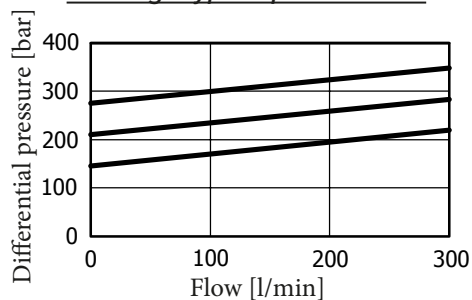

Hydraulic circuit

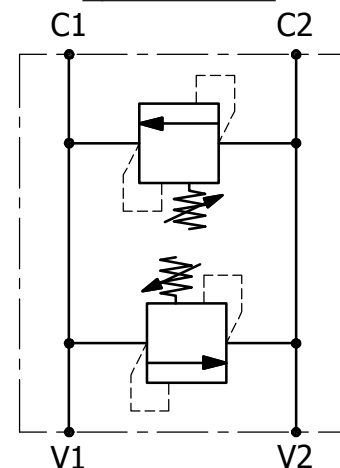

RELIEF & OVERCENTER - ORVSA 200

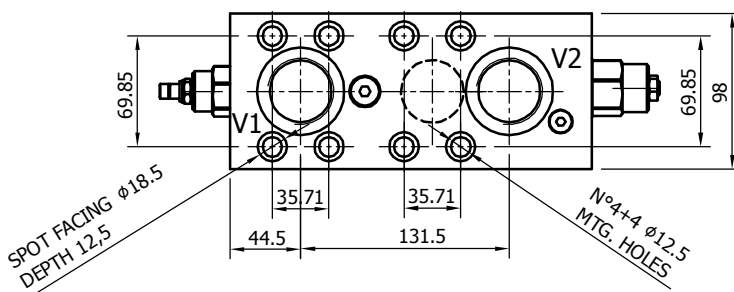
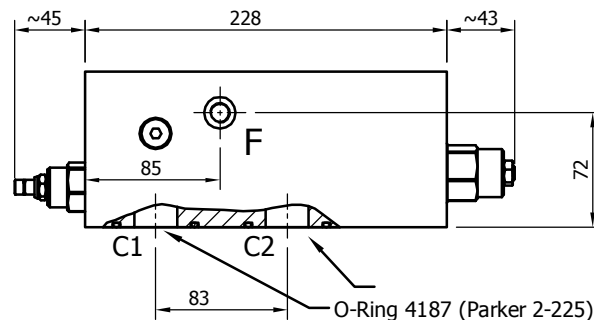
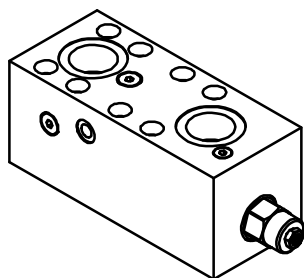

PORTS DIMENSION

V1, V2	1"1/4 BSP
F	1/4" BSP
C1, C2	O-Ring 4187 Parker code 2-225

TECHNICAL DATA

		ORVSA.200.1.C.D75	ORVSA.200.4.C.D75	ORVSA.200.2.C.D75
NOMINAL FLOW	[l/min]	240	240	240
MAXIMUM FLOW	[l/min]	300	300	300
MAXIMUM PRESSURE	[bar]	350	350	350
PILOT RATIO	□	1 (3:1)	4 (10:1)	2 (4.5:1)
OVC RELIEF VALVE SETTING RANGE	[bar]	70-280	140-350	140-350
OVC STANDARD RELIEF SETTING	[bar]	210	210	210
RELIEF VALVE SETTING RANGE	[bar]	C (70-420)	C (70-420)	C (70-420)
RELIEF STANDARD SETTING	[bar]	70	70	70
BLOCK MATERIAL	□	steel	steel	steel
DISTRIBUTOR FITTING	□	D75	D75	D75

OVC cartridge characteristic

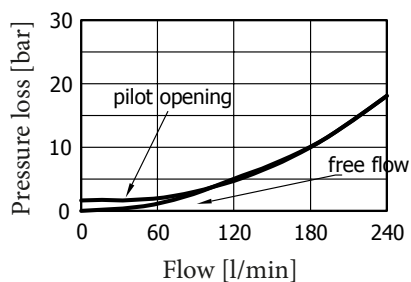

Relief cartridge typical pressure rise

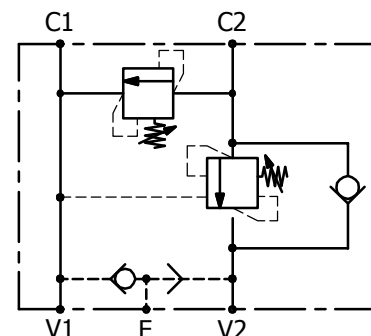
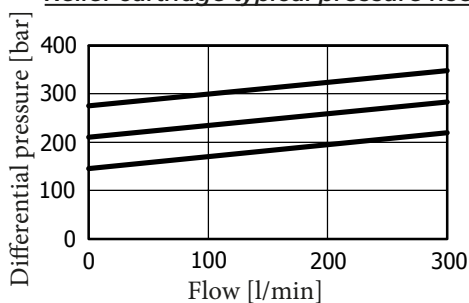

RELIEF & OVERCENTER - DRVSO200EP

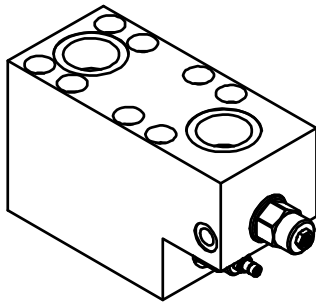

PORTS DIMENSION	
V1, V2	1"1/4 BSP
P	1/4" BSP
C1, C2	O-Ring 4137 Parker code 2-220

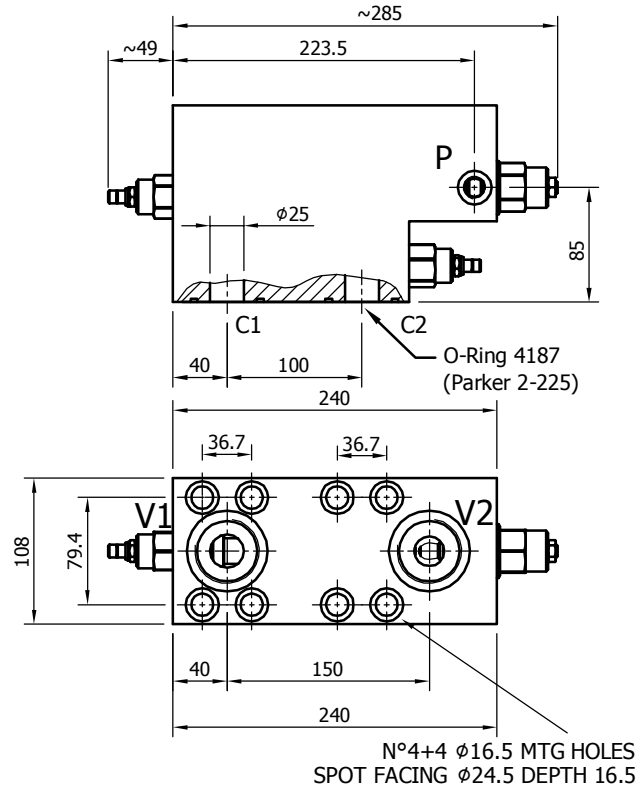

TECHNICAL DATA

		DRVSO200EP.1.C.D75	DRVSO200EP.4.C.D75	DRVSO200EP.2.C.D75
NOMINAL FLOW	[l/min]	240	240	240
MAXIMUM FLOW	[l/min]	300	300	300
MAXIMUM PRESSURE	[bar]	350	350	350
PILOT RATIO	[]	1 (3:1)	4 (10:1)	2 (4.5:1)
OVC RELIEF VALVE SETTING RANGE	[bar]	70-280	140-350	140-350
OVC STANDARD RELIEF SETTING	[bar]	210	210	210
RELIEF VALVE SETTING RANGE	[bar]	C (70-420)	C (70-420)	C (70-420)
RELIEF STANDARD SETTING	[bar]	70	70	70
BLOCK MATERIAL	[]	steel	steel	steel
DISTRIBUTOR FITTING	[]	D75	D75	D75

OVC cartridge characteristic

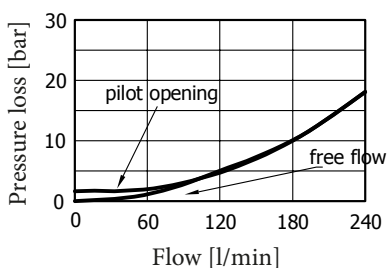

Relief cartridge typical pressure rise

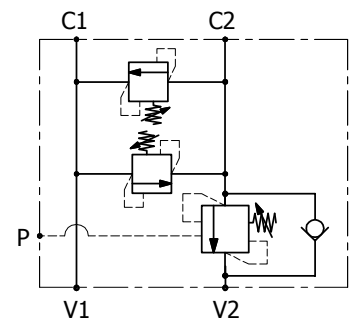
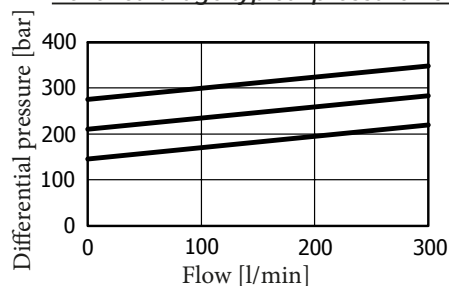

DOUBLE OVERCENTER - OVDA 480

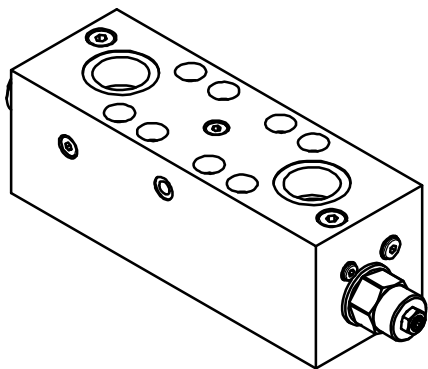

PORTS DIMENSION	
V1, V2	1"1/2 BSP
F	1/4" BSP
C1, C2	O-Ring 4187 Parker code 2-225

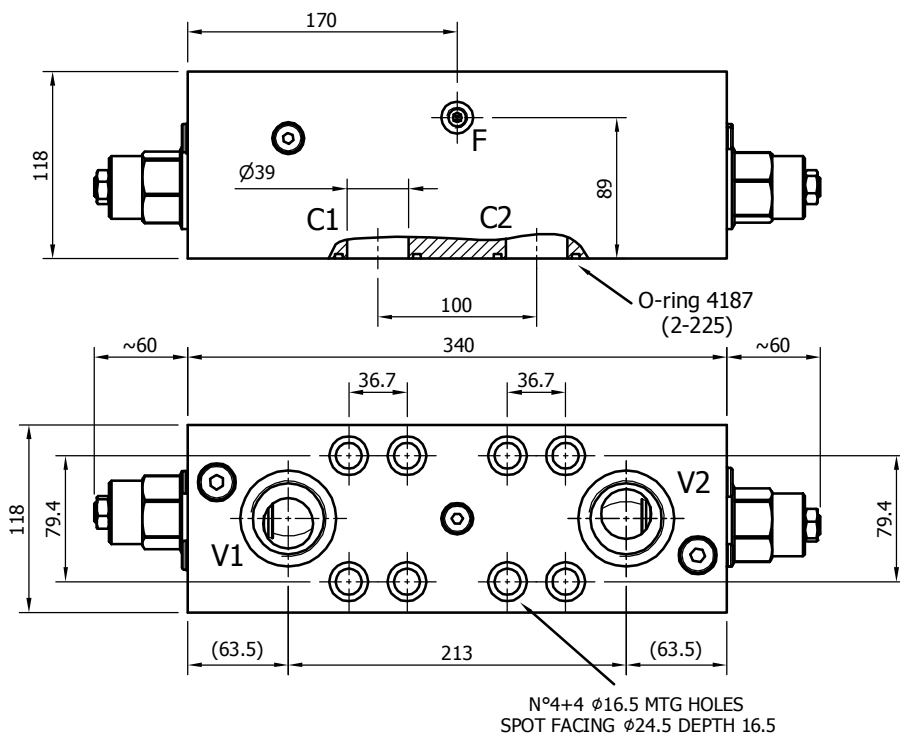

TECHNICAL DATA

	OVDA.480.1.D90	OVDA.480.4.D90	OVDA.480.2.D90
NOMINAL FLOW [l/min]	480	480	480
MAXIMUM FLOW [l/min]	600	600	600
MAXIMUM PRESSURE [bar]	350	350	350
PILOT RATIO	1 (3:1)	4 (10:1)	2 (4.5:1)
RELIEF VALVE SETTING RANGE [bar]	70-280	140-350	140-350
STANDARD RELIEF SETTING [bar]	210	210	210
BLOCK MATERIAL	steel	steel	steel
DISTRIBUTOR FITTING	D90	D90	D90

Cartridge characteristic

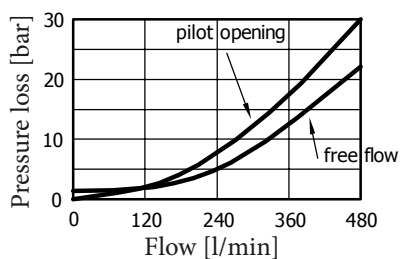

Hydraulic circuit

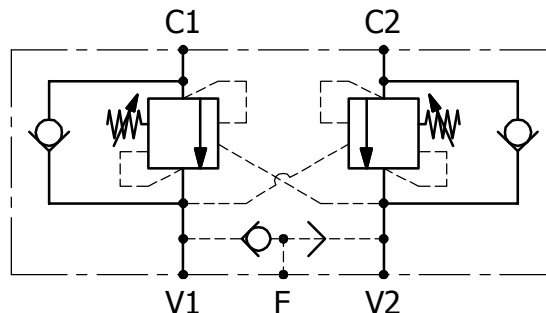

DOUBLE RELIEF - RVDA 380

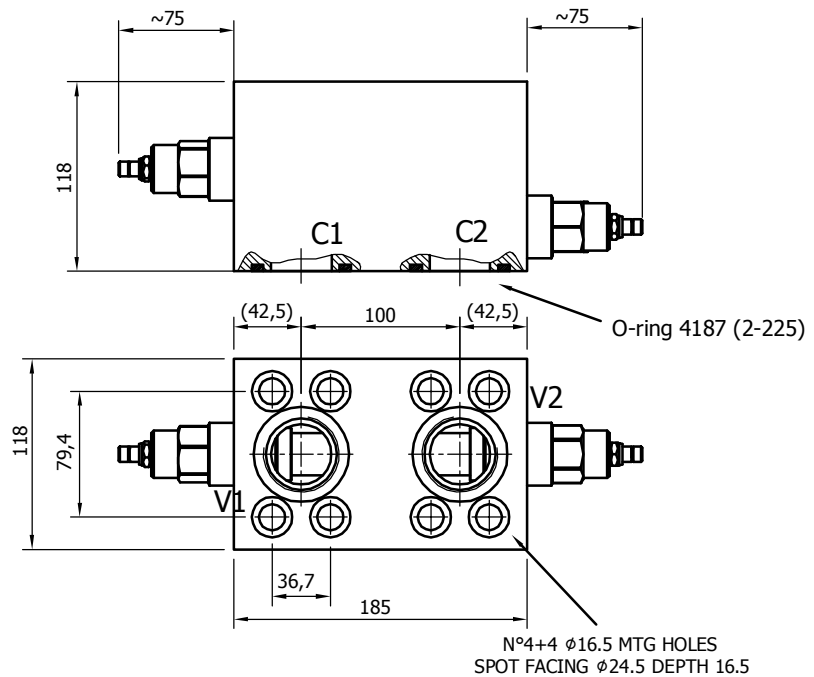
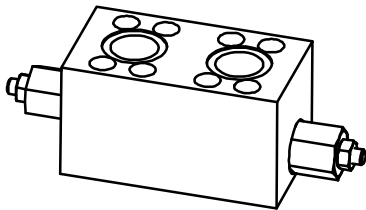

PORTS DIMENSION

V1, V2	1"1/2 BSP
C1, C2	O-Ring 4187 Parker code 2-225

TECHNICAL DATA

RVDA.380.C.D90

RELIEF VALVE MAXIMUM FLOW	[l/min]	380
MAXIMUM PRESSURE	[bar]	350
RELIEF VALVE SETTING RANGE	[bar]	C (70-420)
STANDARD RELIEF SETTING	[bar]	70
BLOCK MATERIAL	□	steel
DISTRIBUTOR FITTING	□	D90

Cartridge typical pressure rise

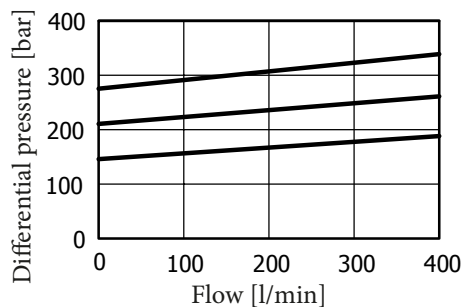

Hydraulic circuit

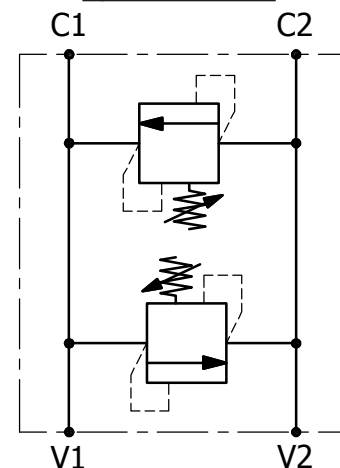

RELIEF & OVERCENTER - ORVSA 480

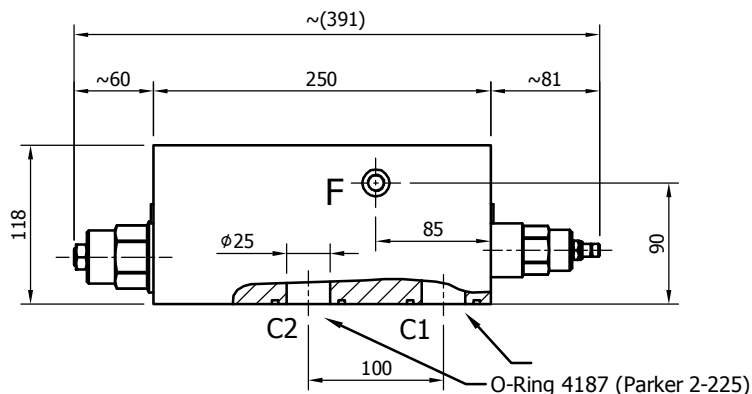
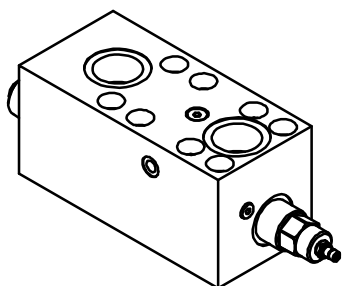

PORTS DIMENSION	
V1, V2	1"1/2 BSP
F	1/4" BSP
C1, C2	O-Ring 4187 Parker code 2-225

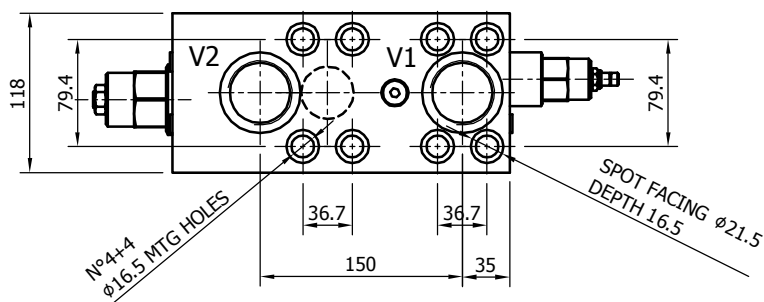

TECHNICAL DATA

		ORVSA.480.1.D90	ORVSA.480.4.D90	ORVSA.480.2.D90
NOMINAL FLOW	[l/min]	480	480	480
MAXIMUM FLOW	[l/min]	600	600	600
MAXIMUM PRESSURE	[bar]	350	350	350
PILOT RATIO	[]	1 (3:1)	4 (10:1)	2 (4.5:1)
OVC RELIEF VALVE SETTING RANGE	[bar]	70-280	140-350	140-350
OVC STANDARD RELIEF SETTING	[bar]	210	210	210
RELIEF VALVE SETTING RANGE	[bar]	C (70-420)	C (70-420)	C (70-420)
RELIEF STANDARD SETTING	[bar]	70	70	70
BLOCK MATERIAL	[]	steel	steel	steel
DISTRIBUTOR FITTING	[]	D90	D90	D90

OVC cartridge characteristic

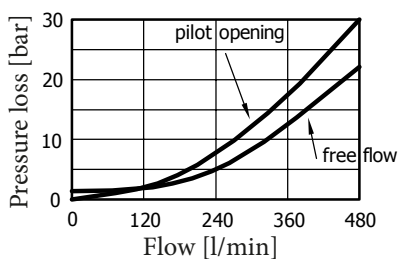

Relief cartridge typical pressure rise

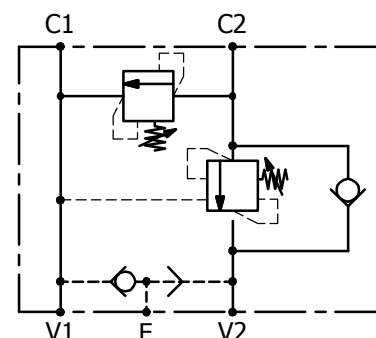
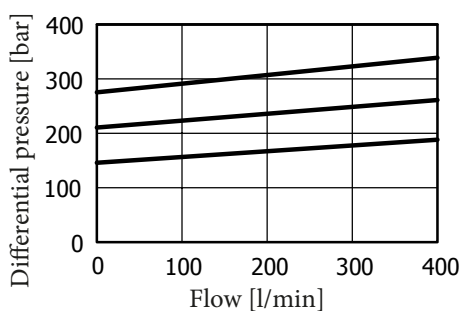

RELIEF & FLUSHING - RVDAP 90

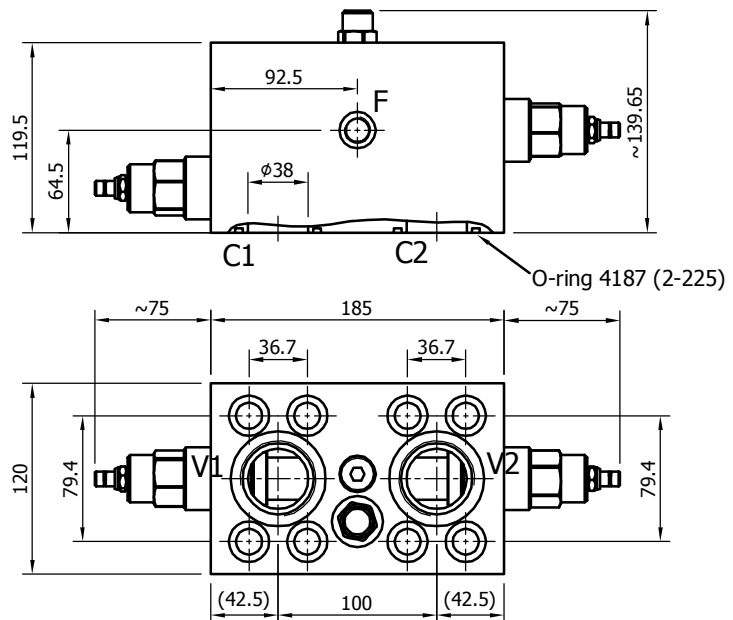
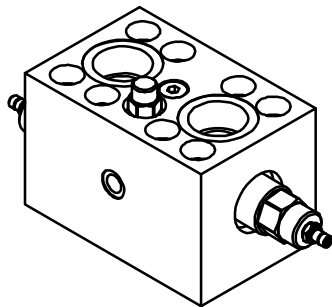

PORTS DIMENSION

V1, V2	1" BSP
F	3/8" BSP
C1, C2	O-Ring 4187 Parker code 2-225

TECHNICAL DATA

		RVDAP90.C.D90
RELIEF VALVE MAXIMUM FLOW	[l/min]	380
RELIEF VALVE SETTING RANGE	[bar]	C (70-420)
STANDARD RELIEF SETTING	[bar]	70
MAXIMUM FLUSHING FLOW	[l/min]	80
MAXIMUM PRESSURE	[bar]	350
BLOCK MATERIAL	□	steel
DISTRIBUTOR FITTING	□	D90

Hydraulic circuit

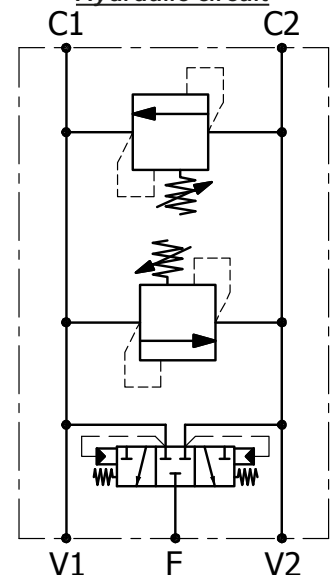

Relief cartridge typical pressure rise

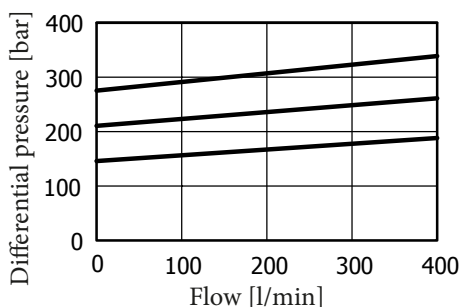

Oil supply flow (from C2 to C1)

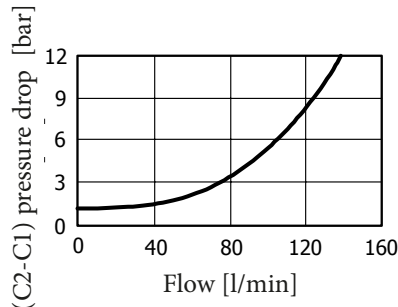

VALVES - ORDERING CODE

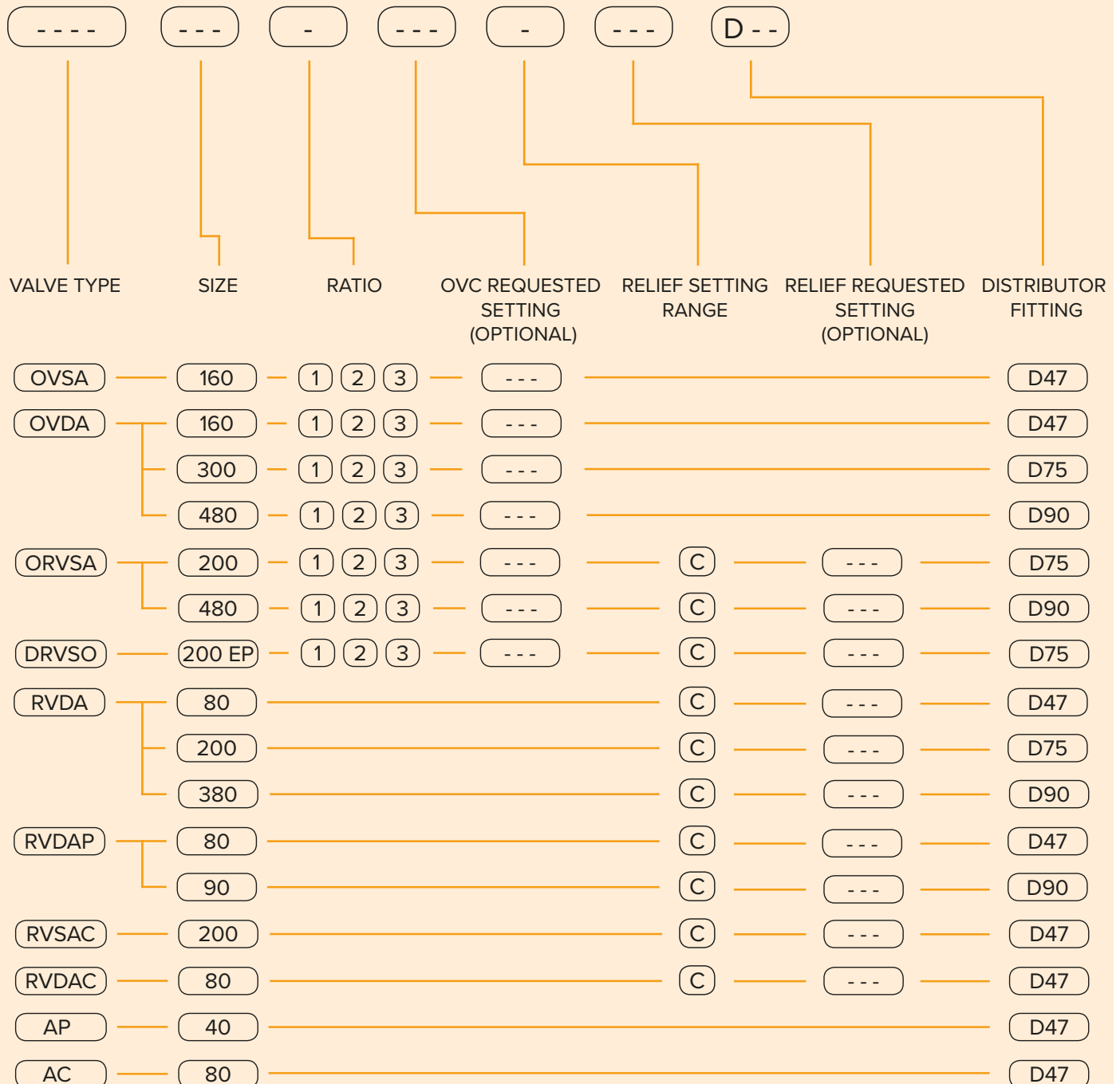

EXAMPLES:

OVDA 160 1 200 D47
 AP 40 D47
 ORVSA 480 3 250 C 200 D90
 ORVSA 200 1 C D75

CONTACT US

CONTACT US

Italgroupp S.r.l.
 Via Pacinotti 20/22
 41010 - Gaggio di Piano (Modena) – Italy

Tel. +39 059 92 42 57
 Fax +39 059 92 01 13
 e-mail: italgroup@italgroup.eu
 internet: <http://www.italgroup.eu>

REACH US



Europe

Austria
Belgium
Croatia
Czech Republic
Cyprus
Denmark
Faroe Islands
France
Finland
Germany
Greece
Iceland
Italy
Netherlands
Norway
Poland
Portugal
Russia
Slovenia
Spain
Sweden
Switzerland
Turkey
Ukraine
United Kingdom

Asia

China
Hong Kong
India
Indonesia
Iran
Israel
Philippines
Russia
Belarus
Singapore
South Korea
Thailand
Taiwan
United Arab Emirates
Vietnam

Africa

Egypt
South Africa
Tunisia

America

Argentina
Brazil
Canada
Chile
Mexico
Peru
USA
Colombia

Oceania

Australia
New Zealand

