

Variable displacement vane pumps (with hydraulic pressure compensator with horse power limiter device)

## PHPK-Type

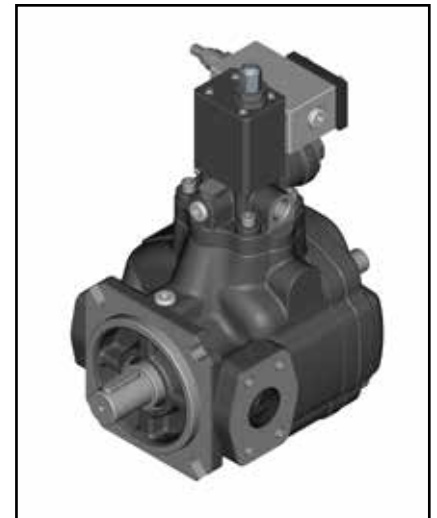

### Key Features:

- Rotation:** Right (viewed from shaft end)
- Mounting flanges:** 4-hole flange (UNI ISO 3019/2)
- Connections:** GAS BSP (UNI ISO 228/1) and SAE
- Integrated mechanical displacement limiter as standard on all pumps.**
- Set-up for combined pumps on request.**

Series/Name	Rated Displacement (cm <sup>3</sup> /rev)	Maximum Flow Capacity at 1450 rpm (L/min)	Maximum Pressure (bar)
01-PHPK-1-20	20	29	180
01-PHPK-1-25	25	36	180
01-PHPK-1-32	32	47	180
01-PHPK-2-40	40	58	180
01-PHPK-2-50	50	73	180
01-PHPK-2-63	63	92	180
01-PHPK-3-80	80	116	180
01-PHPK-3-100	100	145	180
01-PHPK-3-120	120	174	180

**CONTENTS**

GENERAL DESCRIPTION ..... C-3

TECHNICAL DATA ..... C-4

HOW TO ORDER ..... C-5

ORDERING CODE ..... C-6

OVERALL DIMENSIONS ..... C-7

PRESSURE CONTROLS ..... C-10

INSTRUCTIONS FOR INSTALLATION AND USE ..... C-11

**WARNING**

All Berarma pumps have been carefully checked during manufacture and subjected to stringent testing cycles before shipment. To achieve optimum performance, avoid problems and maintain the warranty, the installation instructions enclosed with each pump sold must be strictly observed.

**NOTES**

Before selection and/or use of any Berarma product, it is important that the purchaser carefully analyses all aspects of its application and reviews the information in the current Berarma Technical-Sales catalogues. Due to the many different operating conditions and applications for Berarma products, the purchaser, through their own analysis and testing, is solely responsible for making the final selection of the products and assuring that all performance and safety requirements are met.

Berarma S.r.l. accepts no responsibility for any editing mistakes in this catalogue.

Berarma S.r.l. reserves the right to modify the products and data contained in this catalogue at any time and without prior notice.

## GENERAL DESCRIPTION

BERARMA is continually looking for solutions which would allow it to offer increasingly advanced systems and components to its users.

Therefore, BERARMA has designed a "CONSTANT POWER" control device for its PHPK-type variable displacement vane pumps. This device allows the optimum usage of absorbed power.

The operating principle is based on maintaining the flow-pressure product ( $q \times p$ ) practically constant, so that when the pressure increases, the flow decreases and vice versa, according to a characteristic hyperbolic-type curve.

BERARMA pumps with "CONSTANT POWER" control are especially suited for those systems with a work cycle consisting of two operating phases:

- a first phase characterized by a quick-approach at low pressure;
- a second phase characterized by low speed and high pressure (e.g. forming, drawing, blanking presses, etc.).

In this way, it is possible to set up a system using only one pump, where previously two pumps were required, resulting in obvious cost savings.

The new series of 01 PHPK pumps combines the characteristics of other BERARMA variable displacement vane pumps with

- SILENT RUNNING
- HIGH EFFICIENCY
- LONG WORKING LIFE
- ECONOMY AND SIMPLIFICATION OF HYDRAULIC SYSTEM
- MODULAR DESIGN
- ENERGY SAVING

### What makes the new BERARMA 01 PHPK series of pumps unique?

- DUAL INLET AND OUTLET CHANNELS in the internal pump cartridge
- DUAL AXIAL HYDROSTATIC BALANCING on the distribution plates
- "FORCED" HYDRODYNAMIC LUBRICATION on journal bearings
- REDUCTION IN WEAR on internal pump cartridge parts
- INNOVATIVE SHAPES AND DESIGN
- 180 BAR WORKING PRESSURE

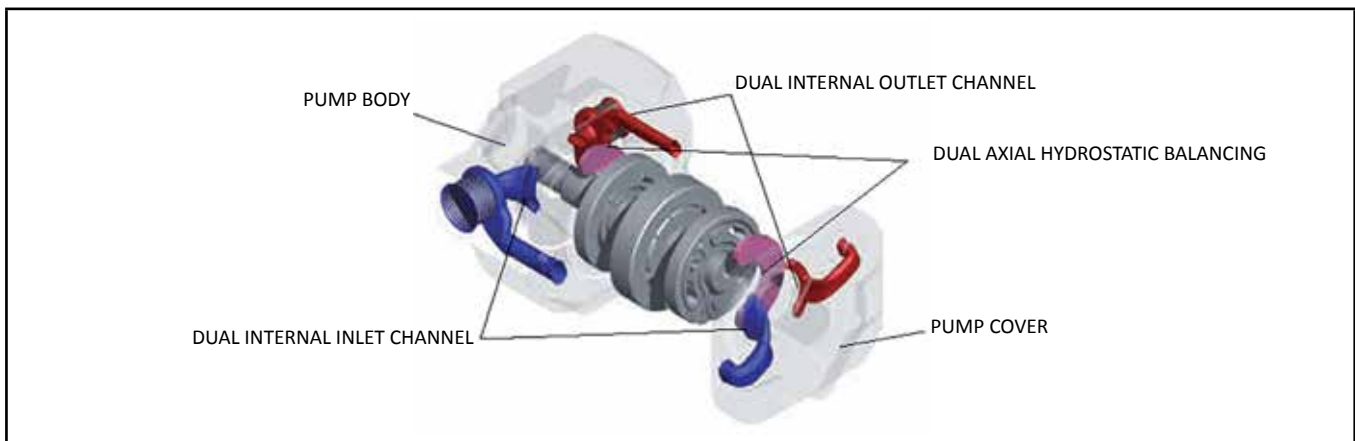

**TECHNICAL DATA**

NOMINAL SIZE	SIZE 1			SIZE 2			SIZE 3		
Geometric displacement according to UNI-ISO 3662 (cm <sup>3</sup> /r)	20	25	32	40	50	63	80	100	120
Actual displacement (cm <sup>3</sup> /r) Due to manufacturing tolerances, the value can vary by approx. ± 3%	21	26	33	42	51	63	80	100	123
Maximum working pressure (bar)	180								
Pressure setting range (bar)	H: 40 ÷ 180								
Permitted maximum drain port pressure (bar)	1								
Inlet pressure (bar)	0.8 - 1.5 absolute								
Speed range (r/min)	800 ÷ 1800			800 ÷ 1500					
Rotation direction (viewed from shaft end)	R - Right								
Loads on drive shaft	NO RADIAL OR AXIAL LOADS ALLOWED								
Maximum torque on primary shaft (Nm)   Tmax	250			586			900		
Hydraulic fluid	HM hydraulic oil according to ISO 6743/4 HLP according to DIN 5124/2 for other fluids contact Berarma Technical-Sales Service								
Viscosity range (cSt, mm <sup>2</sup> /s)	22 - 68 at operating temperature								
Starting viscosity under full flow conditions (cSt, mm <sup>2</sup> /s)	400 max								
Viscosity index according to ISO 2909	100 min								
Inlet fluid temperature range (°C)	+15 / +60 - pay attention to viscosity range								
Maximum acceptable fluid contamination level	20/18/15 according to ISO 4406/99, CLASS 9 according to NAS 1638								
Recommended fluid contamination level for a longer pump working life	18/16/13 according to ISO 4406/99, CLASS 7 according to NAS 1638								
Moment of inertia (kgm <sup>2</sup> )	0,00050			0,00909			0,015		
	<b>Single pump weight (kg)</b>								
Single stage pressure compensator	20			45.2			58.7		
PCS002	20.5			45.7			59.2		
PCS003	20			45.2			58.7		
For further information and/or different operating conditions, please contact Berarma Technical-Sales Service									

## HOW TO ORDER

The PHPK pump can be ordered in two different ways:

- 1) starting from the power value of the motor (contact BERARMA Technical Service to find out the available power values) and from the maximum working pressure, thus obtaining a characteristic curve making it possible for the pump to optimize installed power usage;
- 2) starting from the minimum flow value to be obtained at the previously defined maximum working pressure. In this way the motor power and the characteristic curve are determined from defined operating conditions.

Starting from the motor power value and maximum working pressure value indicated in the ordering code, BERARMA performs the bench calibration of the constant power device so that the actual characteristic curve of the pump approximates the theoretical hyperbolic curve.

**Note: the pressure setting of the constant power device must not be changed by users.**

The pump absorbed power can be calculated using the following formula:

$$P \text{ [kW]} = \frac{p \text{ [bar]} \times q \text{ [l/min]}}{600 \times \eta}$$

where:

$\eta$  = pump total efficiency ( $\eta \sim 0.88$ , purely indicative).

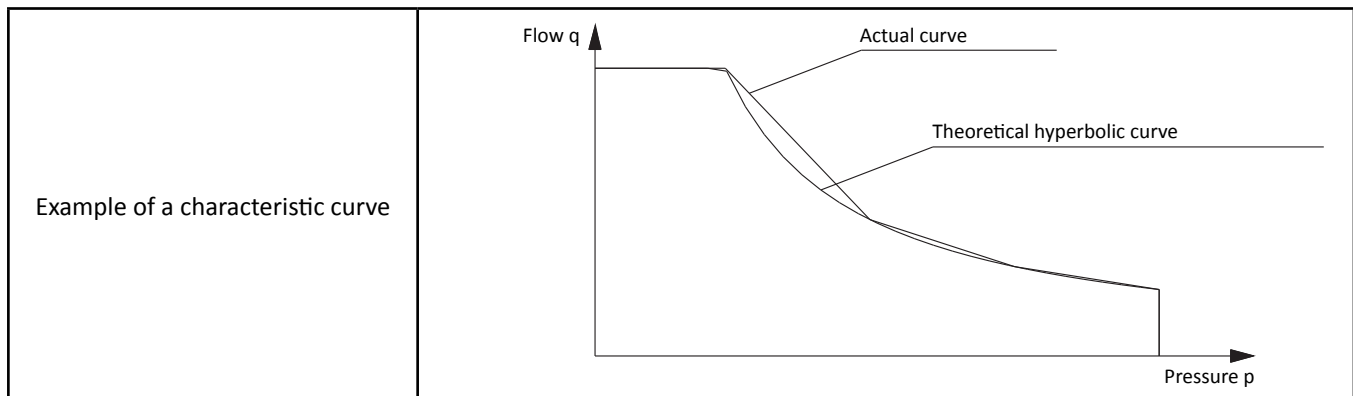

**ORDERING CODE**

**ORDERING CODE**

Series/ Name	Size Displacement	Flange	Pressure setting	Rotation	Seals	Combined pumps	Pressure controls	Max Power	Max Pressure
<b>01 PHPK</b>			<b>H</b>	<b>R</b>					

Code	Size	Displacement (cm <sup>3</sup> /r)
<b>05 - 16</b>	05	16
<b>1 - 20</b>	1	20
<b>1 - 25</b>	1	25
<b>1 - 32</b>	1	32
<b>2 - 40</b>	2	40
<b>2 - 50</b>	2	50
<b>2 - 63</b>	2	63
<b>3-80</b>	3	80
<b>3-100</b>	3	100
<b>3-120</b>	3	120

Code	Flange	Thread
<b>F</b>	UNI ISO3019/2 - 4 fori	GAS UNI ISO 228/1; SAE

Code	Pressure setting
<b>H</b>	40 - 180 bar

Code	Rotation Direction
<b>R</b>	Right (viewed from shaft end)

Code	Seals
<b>M</b>	NBR
<b>E</b>	FPM (viton)

Code	Combined pumps
<b>/</b>	Omit for single pump
<b>A</b>	Primary pump and/or intermediate pump

Code	Pressure controls
<b>/</b>	Hydraulic single stage pressure control
<b>PCS002</b>	Hydraulic control with remote pressure setting
<b>PCS003</b>	Hydraulic two stage pressure control

For further information regarding pressure control solutions, please see page 10

	Request data
<b>kW</b>	Indicate the power value of the motor
<b>bar</b>	Indicate the max. working pressure

# OVERALL DIMENSIONS

## 01 PHPK 1 20-25-32

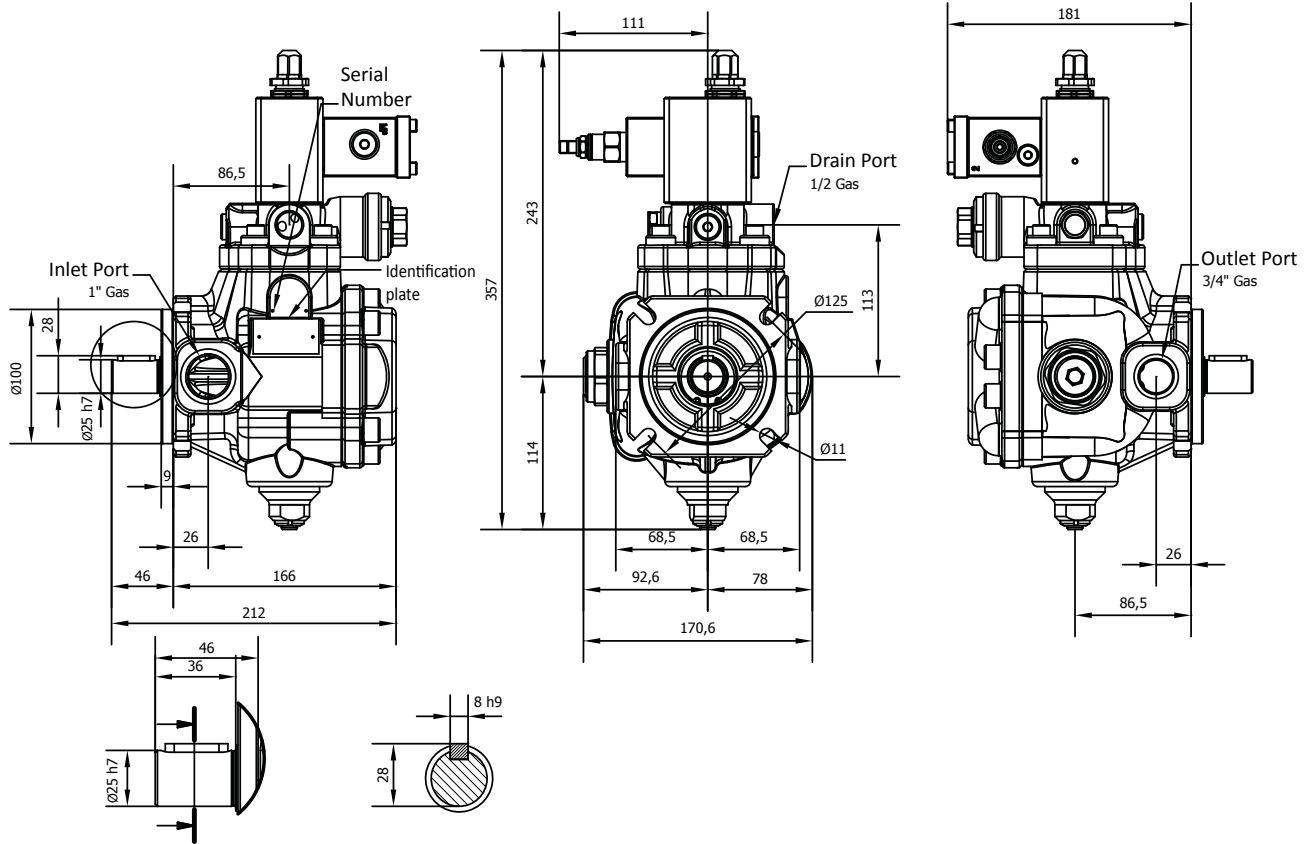

**OVERALL DIMENSIONS**

### THRU-DRIVE SHAFT (-A)

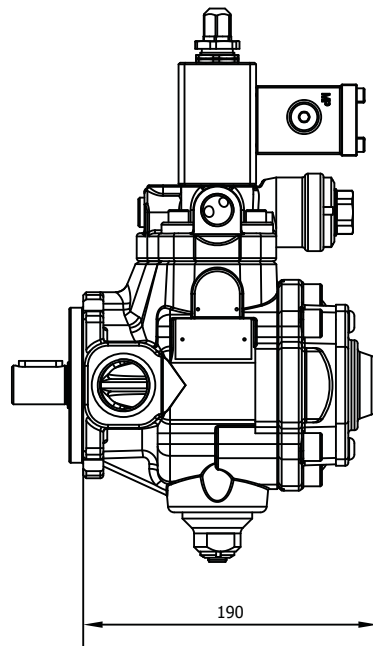

**01 PHPK 2 40-50-63**

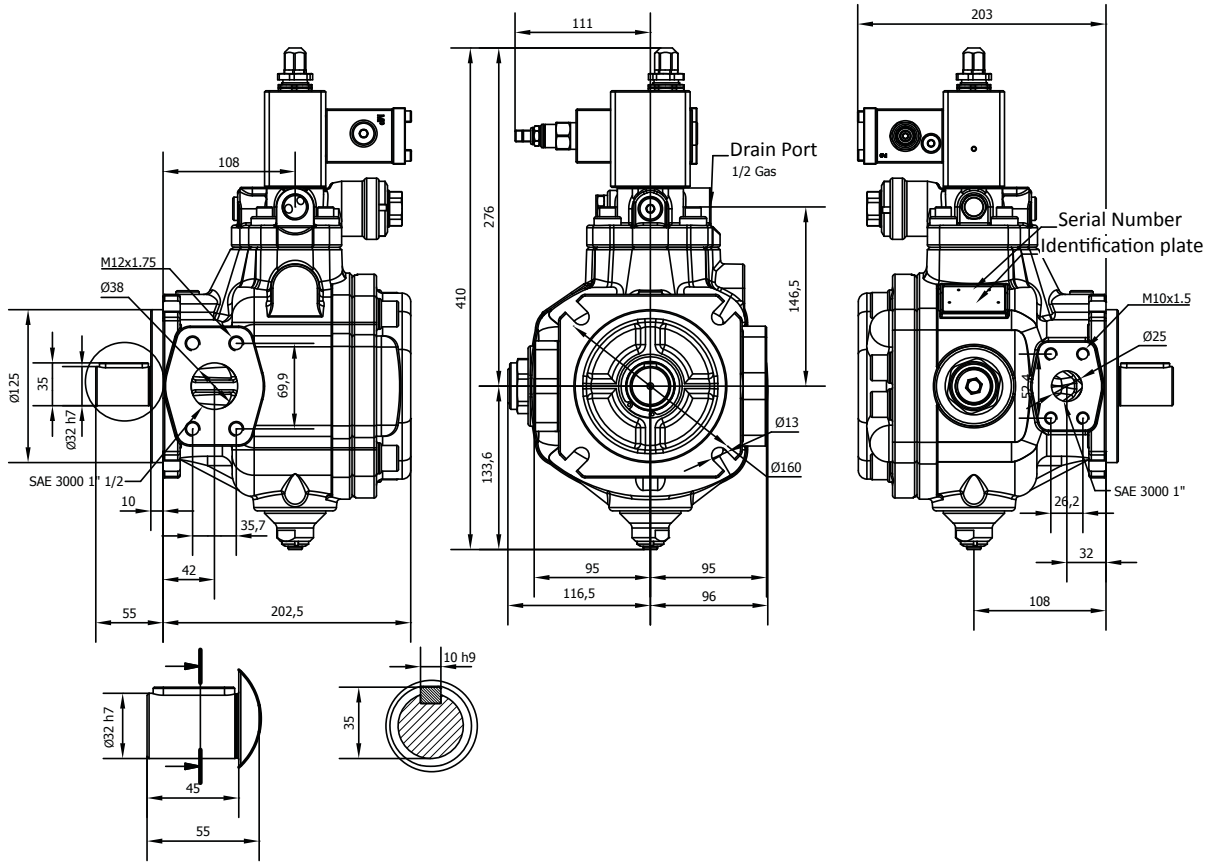

**THRU-DRIVE SHAFT (-A)**

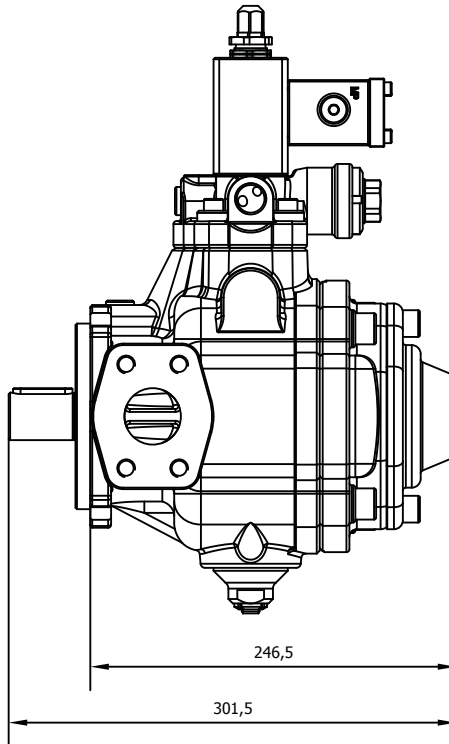



**01 PHPK 3 80-100-120**

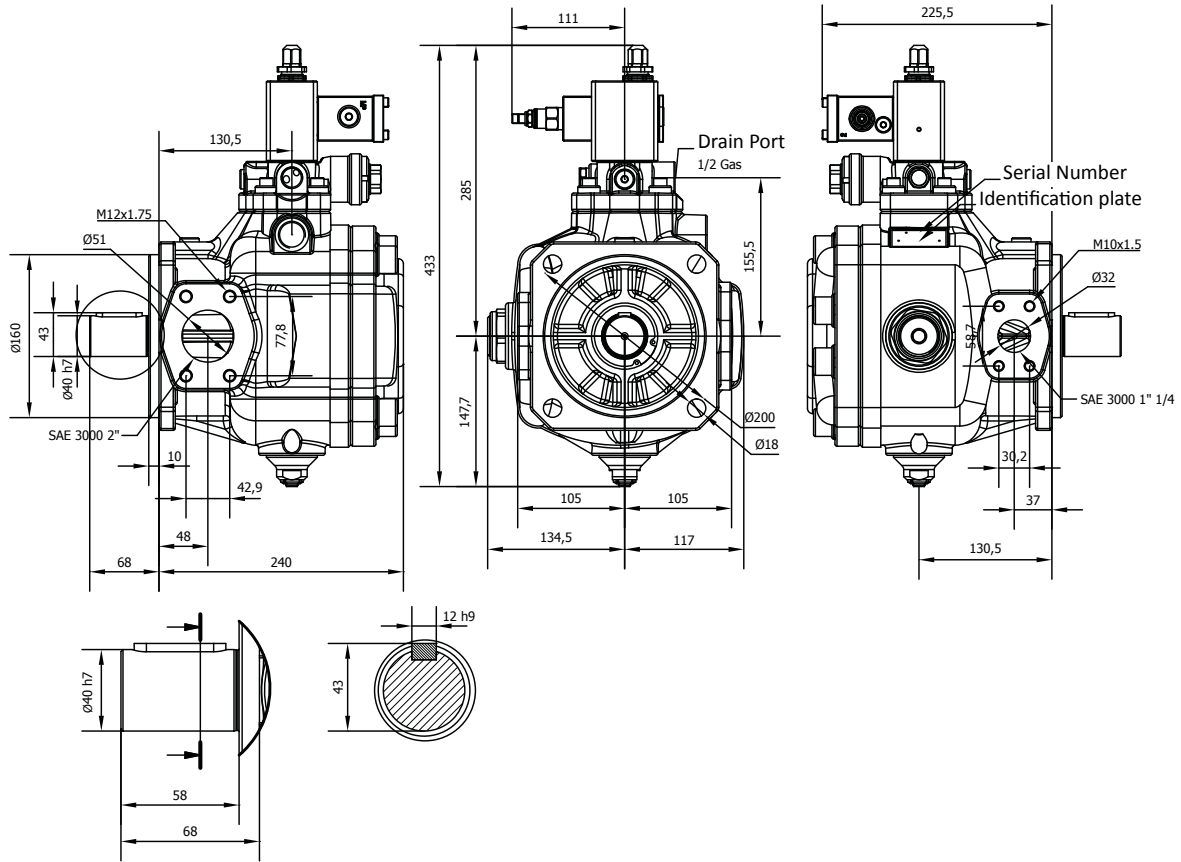

**OVERALL DIMENSIONS**

**THRU-DRIVE SHAFT (-A)**

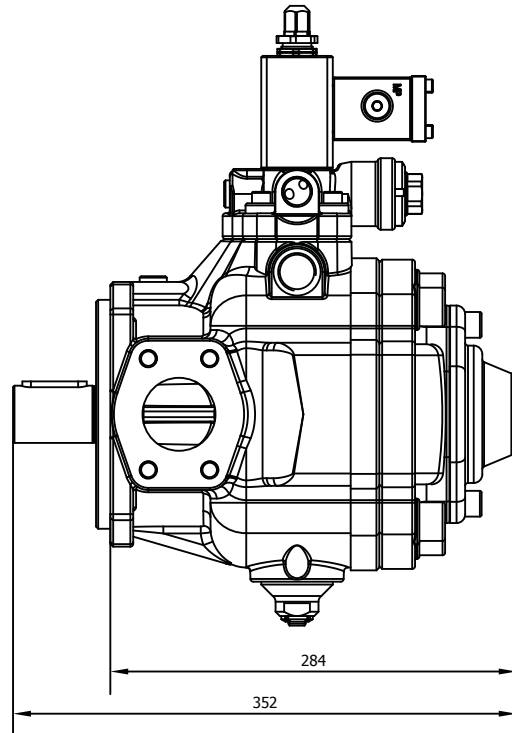

**PRESSURE CONTROLS**

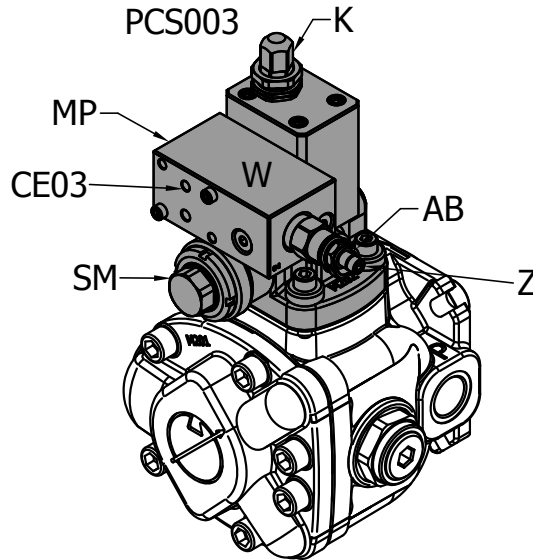
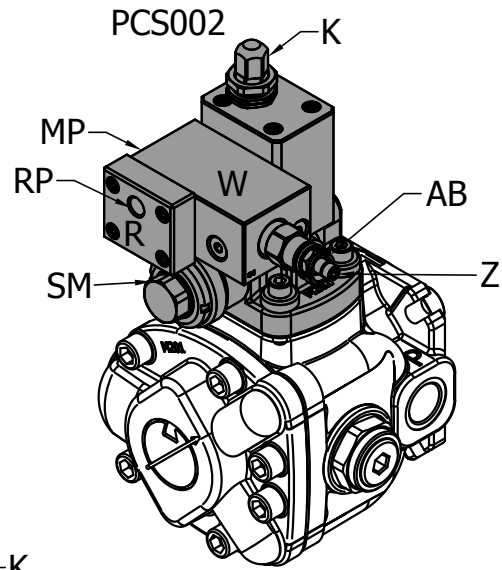
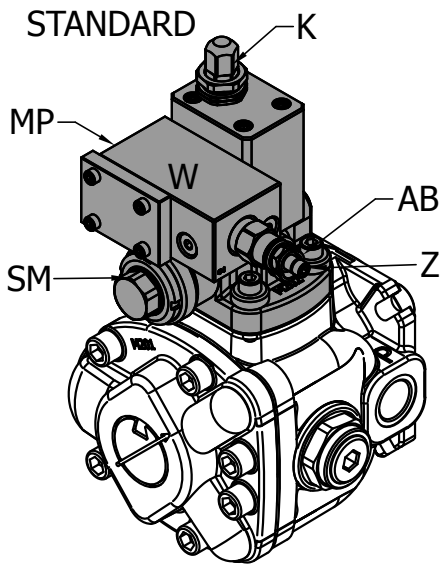

Control Devices	
"SM"	"Minimum pressure" spring adjustment (do not tamper)
"W"	Maximum pressure relief valve (do not tamper)
"R"	Remote control block
"K"	Horse power block (do not tamper)
"Z"	Maximum pressure setting (do not tamper)

Conessioni	
"AB" – Air Bleed	1/4" Gas BSP ■
"MP" – Pressure gauge	1/4" Gas BSP ■
"RP" – Remote control port	1/4" Gas BSP □
Surface – "C03"	ISO 4401-03 (CETOP 03) □
□	Supplied port closed
■	Must be connected

<b>STANDARD</b>	Hydraulic single stage pressure control
<b>PCS002</b>	Hydraulic control with remote pressure setting
<b>PCS003</b>	Hydraulic two stage pressure control

## INSTRUCTIONS FOR INSTALLATION AND USE

Pumps from the 01 PHPK 1 series can be mounted in any position.

**Pump type 01 PHPK 2/3 must be mounted with the shaft HORIZONTAL and the compensator device upward (see figure).**

When the pump is installed over the reservoir fluid level, pay attention to the inlet pressure (see page 4).

**Cleanliness is essential during assembly!**

Motor-pump coupling must be made with a self-aligning flexible coupling with convex teeth and a polyamide cam. When assembling make sure that:

- **the distance between the half-couplings strictly falls within the specified values (see page 12);**
- **the pump shaft and the motor shaft are accurately aligned: concentricity within 0.05 mm, angular displacement within 0.2° (see drawing);**
- **strictly no radial or axial loads on the pump shaft.**

Other types of motor-pump couplings are not permitted.

The fluid tank must be suitably sized in order to exchange the thermal power generated by the various system components and to provide a low recycle rate (tank capacity approximately 4 times the flow rate per minute of the pump). In systems where the pump runs for a long time under zero flow setting conditions, the installation of a heat exchanger in the drain line is recommended. The pressure on the drain port must never exceed the value specified on page 4.

**Maximum operating temperature must not exceed 60°C under any circumstances.**

To ensure the maximum pump working life, the inlet fluid temperature must never be above 50°C.

**Suction pipe.** The suction pipe should be as short as possible, with a small number of bends and without internal section changes. The pipe-end inside the tank should be cut at 45°, should have a minimum distance from the tank bottom of not less than 50 mm, and there should always be a minimum height of suction of 100 mm. Select the clear width of the pipes according to the pump inlet ports. **The suction pipe should be completely airtight in order to avoid air intake which could be extremely damaging to the pump.**

**Drain pipe.** The drain pipe must always be independent from the other return lines, connected directly to the tank, and extended sufficiently inside the tank so as to be below the minimum fluid level to avoid generating foam and to prevent emptying when the pump is not running. Moreover, the drain pipe must also be at the highest possible position in relation to the pump in order to always prevent fluid emptying from the pump, and must be free of restrictions. **The drain pipe should be as far as possible from the suction pipe to prevent hot fluid being circulated.**

**Pressure line.** Ensure that the pressure line is strong enough. It is recommended that a non-return valve (check valve) is installed on the pump pressure line as well as an automatic air bleed valve, for trouble free operation.

Ensure that any valves, taps and gate valves on the suction and pressure pipes are fully opened and all protective caps removed. Fill the pump through the case drain port and replace the drain pipework. Check that the reservoir is full of fluid.

**Ensure that the pump shaft can be rotated manually without any resistance.**

Check that the motor rotation direction is the same as the pump rotation direction: right-hand rotation (clockwise) viewed from shaft end of the pump.

Start the motor (in jogging mode), allowing free circulation of fluid to the tank in order to facilitate priming.

**The pump should prime within 5 seconds. If it does not, switch it off and investigate the cause. The pump should not run empty.**

**During INITIAL INSTALLATION, the pump must run under maximum flow conditions (P connected to T), with the fluid flowing directly into the tank, without pressure for several minutes.** Care should be taken to eliminate all the air from the system during this process. To facilitate this operation, there is an air bleed port on the pressure compensator device: unscrew the cap to bleed the air and then close the cap.

Subsequent start-ups under zero flow setting conditions are admissible only with pressure not exceeding 30 bar, and with the system and pump completely filled with fluid.

**If the flow regulator unit is set to less than 50% of the nominal flow-rate, the pump can only start on condition that the system and the pump are completely filled with fluid.**

**During the initial and subsequent starting operations, it is necessary that the pump (ambient) and fluid temperature do**

**INSTRUCTIONS FOR INSTALLATION AND USE**

not differ by more than 20°C. If this is the case, the pump should be switched on only for short intervals of approximately 1-2 seconds (start/stop mode) without pressure, until the temperatures are balanced.

All Berarma products are covered by a **1 YEAR WARRANTY** for manufacturing or material defects effective from the shipment date, but in any case **NO LONGER THAN 18 MONTHS FROM THE PRODUCTION BATCH DATE**. The warranty is for the exclusive benefit of the original purchaser of the products.

For further information, please contact the Berarma Technical-Sales Service.

